

EMERALD SKY

American DJ

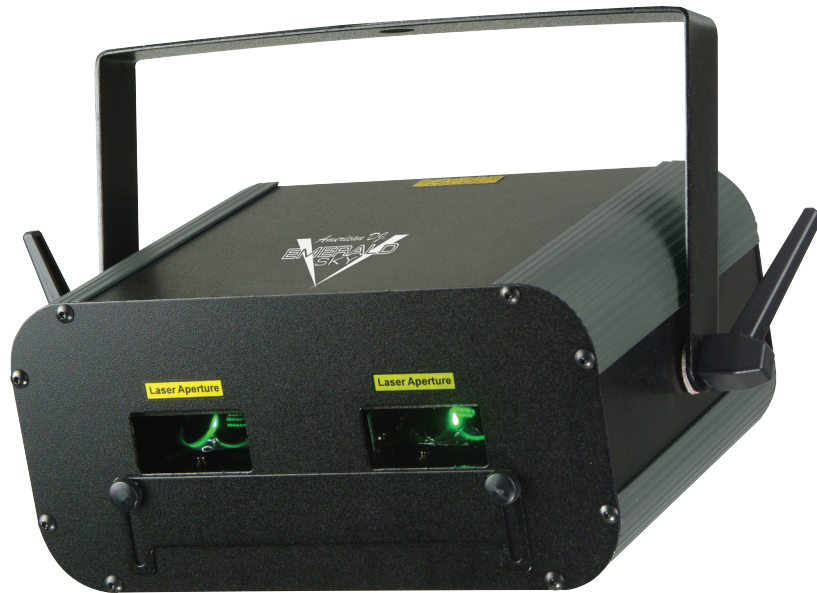

User Instructions

Emerald Sky™

General Introduction

Unpacking: Thank you for purchasing the Emerald Sky™ by American DJ®. Every Emerald Sky™ has been thoroughly tested and has been shipped in perfect operating condition. Carefully check the shipping carton for damage that may have occurred during shipping. If the carton appears to be damaged, carefully inspect your unit for any damage and be sure all equipment necessary to operate the unit has arrived intact. In the event damage has been found or parts are missing, please contact our toll free customer support number for further instructions. Please do not return the unit to your dealer without first contacting customer support.

Introduction: The Emerald Sky™ is a unique two channel, DMX intelligent dual green laser effect that creates several different patterns. The unit uses two lasers to project several patterns over a wide area. This unit can be used as a stand alone, sound-active unit or in a Master/Slave configuration. The unit can also be controlled via DMX controller. The unit's sound sensitivity may be adjusted by a sensitivity knob on the rear of the unit. *For best results use fog or special effects smoke to enhance the beams projections.*

Customer Support: American DJ® provides a toll free customer support line, to provide set up help and to answer any question should you encounter problems during your set up or initial operation. You may also visit us on the web at www.americandj.com for any comments or suggestions. For service related issue please contact American DJ®. Service Hours are Monday through Friday 9:00 a.m. to 5:00 p.m. Pacific Standard Time.

Voice: (800) 322-6337

Fax: (323) 582-2941

E-mail: support@americandj.com

To purchase parts online visit <http://parts.americandj.com>

Caution! There are no user serviceable parts inside this unit. Do not attempt any repairs yourself, doing so will void your manufactures warranty. In the unlikely event your unit may require service please contact American DJ customer support.

Please recycle the shipping carton when ever possible.

Please carefully read and understand the instructions in this manual thoroughly before attempting to operate this unit. These instructions contain important safety information regarding the use and maintenance of this unit. Please keep this manual with the unit, for future reference.

CAUTION IMPORTANT! When installing this projector, make sure that it is mounted in a manner that prevents the audience from looking directly into the beam, and the beam from striking the audience.

- 4.9mW Green Laser Diode
- Dual Laser Output
- Sound Active and Auto Mode
- DMX-512 Protocol Compatible (Uses Two DMX Channels)
- Stand Alone and Master/Slave Operation
- Volume Sensitivity Knob

The Emerald Sky™ carries a 90 day limited warranty. Please fill out the enclosed warranty card to validate your purchase. All returned service items whether under warranty or not, must be freight pre-paid and accompany a return authorization (R.A.) number. The R.A. number must be clearly written on the outside of the return package. A brief description of the problem as well as the R.A. number must also be written down on a piece of paper included in the shipping carton. If the unit is under warranty, you must provide a copy of your proof of purchase invoice. You may obtain a R.A. number by contacting our customer support team on our toll free customer support number. All packages returned to the service department not displaying a R.A. number on the outside of the package will be returned to the shipper.



Safety Issues: This unit may blow the fuse if the maximum allotted load of 2 amps is reached.

- To reduce the risk of electrical shock or fire, do not expose this unit rain or moisture.
- Do not spill water or other liquids into or on to your unit.
- Do not attempt to remove or break off the ground prong from the electrical cord. This prong is used to reduce the risk of electrical shock and fire in case of an internal short. Do not attempt to operate this unit if the power cord has been frayed or broken.
- Disconnect from main power before making any type of connection.
- Do not remove the cover under any conditions. There are no user serviceable parts inside.
- Always be sure to mount this unit in an area that will allow proper ventilation. Allow about 6" (15cm) between this device and a wall.
- Do not attempt to operate this unit, if it becomes damaged.
- This unit is intended for indoor use only, use of this product outdoors voids all warranties.
- During long periods of non-use, disconnect the unit's main power.
- Always mount this unit in safe and stable matter.
- Power cords should be routed so they are not likely to be walked on, pinched by items placed upon or against them.
- Cleaning -The fixture should be cleaned only as recommended by the manufacturer. See page 6 for cleaning details.
- Heat -The appliance should be situated away from heat sources such as radiators, heat registers, stoves, or other appliances (including amplifiers) that produce heat.
- The fixture should be serviced by qualified service personnel when:
 - A. The power-supply cord or the plug has been damaged.
 - B. Objects have fallen on, or liquid has been spilled into the unit.
 - C. The unit has been exposed to rain or water.
 - D. The unit does not appear to operate normally or exhibits a marked change in performance.

NON-INTERLOCKED HOUSING WARNING

The Emerald Sky contains high power laser devices internally. **Do not** open the laser housing, due to the potential exposure to unsafe levels of laser radiation. The laser power levels, if the unit is opened, can cause instant blindness, skin burns and fires.

**STOP AND READ ALL LASER SAFETY DATA
OPERATION INSTRUCTIONS AND LASER SAFETY**

The light source emitted from this product can potentially cause eye injury if not set up and used properly. The light source emitted from a laser is very different from any other light sources with which you may be aware of. Laser light is thousands of times more concentrated than any light from any other kind of light source. This concentration of light can cause instant eye injuries, primarily by burning the retina (the back of your eyeball containing cells that are sensitive to light). Even if you cannot feel “heat” from a laser beam, it can still potentially injure or blind you or your audience. Even very small amounts of laser beam light are potentially hazardous even at long distances. Laser eye injuries can be sustained faster than you can blink.

Do not think that because this laser splits the laser beam into hundreds of beams and that the laser beam is scanned out in high speed, that an individual laser beam is safe for eye exposure. This laser uses dozens of milliwatts of laser power (Class 3B levels internally) before it splits into multiple beams (Class 3R levels). Many of the individual beams are potentially hazardous to the eyes.

Do not think that because the laser light is moving, it is safe. This is not true. Nor, do the laser beams always move. Since eye injuries can occur instantly, it is critical to prevent even the smallest possibility of any direct eye exposure. In the laser safety regulation, it is not legal to aim Class 3R lasers in areas which people can get exposed. This is true even if it is aimed below people’s faces, such as on a dance floor.

Do not operate the laser without first reading and understanding all safety and technical data in this manual.

Always set up and install all laser effects so that all laser light is at least 3 meters (9.8 feet) above the floor on which people can stand.

After setting up, and before public use, test laser to ensure proper function. Do not use if any defect is detected. Do not use if laser emits only one or two laser beams rather than dozens/hundreds, as this could indicate damage to the diffraction grating optic, and could allow emission of higher laser levels above Class 3R.

Do not point lasers at people or animals. Never look into the laser aperture or laser beams.

Do not point lasers in areas in which people can potentially get exposed, such as uncontrolled balconies, etc.

Do not point lasers at highly reflective surfaces, such as windows, mirrors and shiny metal. Even laser reflections can be hazardous.

Never point a laser at aircraft, this is a federal offense.

Never point un-terminated laser beams into the sky.

Do not expose the output optic (aperture) to cleaning chemicals.

Do not use laser if the laser appears to be emitting only one or two beams.

Do not use the laser if the housing is damaged, the housing is open, or if the optics appear damaged in any way.

Never open the laser housing. The high laser power levels inside of the protective housing can start fires, burn skin and will cause instant eye injury.

Never leave this device running unattended.

The operation of a class 3R laser show is only allowed if the show is controlled by a skilled and well- trained operator, familiar with the data included in this manual.

The legal requirements for using laser entertainment products vary from country to country. The user is responsible for the legal requirements at the location/country of use.

Always use proper lighting safety cables when hanging lights and effects overhead.

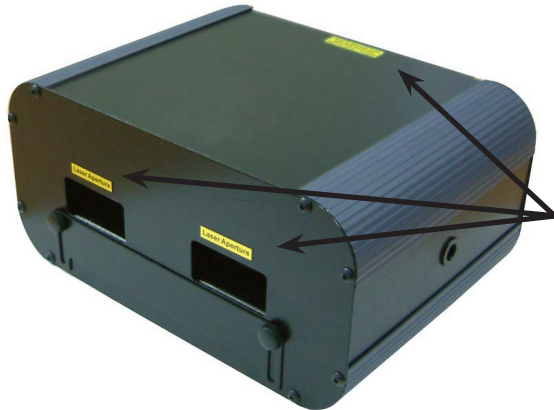
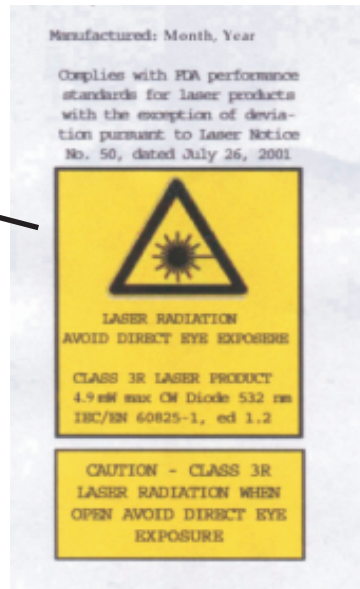

Laser Aperture

CAUTION IMPORTANT! When installing this projector, make sure that it is mounted in a manner that prevents the audience from looking directly into the beam, and the beam from striking the audience.

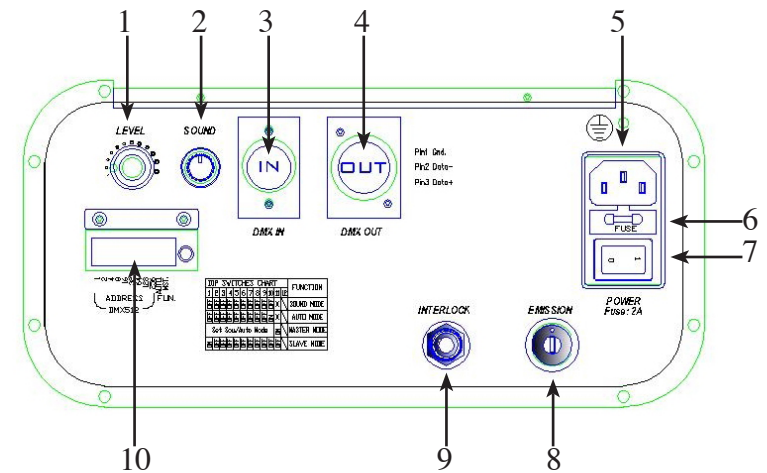

1. Audio Sensitivity Knob - This adjusts the audio sensitivity of the internal microphone. Turning the sensitivity knob in the clockwise direction will increase the sensitivity to sound. Turning the knob in the counter clockwise direction will decrease the fixture’s sensitivity to sound. If the knob is turned completely in the counter-clockwise direction the sound sensitivity function will turn off.

2. Microphone - This microphone receives external low frequencies to trigger the unit in Sound-Active mode. This microphone is designed to receive low frequency sounds only, tapping on the microphone and high pitch sounds may not trigger the unit.

3. XLR Input Jack - This male input jack is used to accept an incoming DMX signal or Master/Slave signal.

4. XLR Output Jack - This female output jack is used to transmit the incoming DMX signal to another DMX fixture, or transmit a Master/Slave signal to the next Emerald Sky™ in the chain. For best results in DMX or Master/Slave mode terminate this jack if it is the last unit in the chain. See “Terminator” on page 10.

5. Power Cord - This cord is used to supply main power to the fixture. Be sure the main power matches the required power of your fixture. The rated power requirements are clearly marked on the rear panel of the unit.

6. Fuse - Fuse Holder - This housing stores a 2 amp GMA protective fuse. Never defeat the fuse, the fuse is designed to protect the electronics in the event of severe power fluctuations. Always be sure to replace the fuse with an exact match as the one being replaced, unless otherwise told to do so by an authorized American DJ® service technician.

7. Power Switch - This switch will control the unit's main power. When the unit is powered on, the red LED switch will glow. **Remember you must have the Power Ignition key in and turned to the "On" position for this switch to work.**

8. Power Ignition - Before turning on the power the key has to be entered and turned. If this is not done the unit will not power on, and the power switch will not operate.

9. Controller Jack - This jack is for use with the optional controller only. This controller is used to control the blackout function. Do not attempt to connect an audio signal to this jack, this will damage the PC board and void your manufacturer's warranty!

10. Dip Switches - These switches serve three functions. In stand alone mode, these switches will set the sound active mode or auto mode. In master-slave mode these switches are used to assign the Master and Slave unit and set the sound active mode or auto mode. In DMX mode these switches are used to assign a DMX address to the unit. In DMX mode each switch corresponds to a specific value based on binary code. See pages 8-9 for a detailed explanation of DMX binary code.

Power Supply: Before plugging your unit in, be sure the source voltage in your area matches the required voltage for your American DJ® Emerald Sky™. The American DJ® Emerald Sky™ is 120v only. Because line voltage may vary from venue to venue, you should be sure your unit voltages matches the wall outlet voltage before attempting to operate you fixture.

DMX-512: *DMX is short for Digital Multiplex. This is a universal protocol used as a form of communication between intelligent fixtures and controllers.* A DMX controller sends DMX data instructions from the controller to the fixture. DMX data is sent as serial data that travels from fixture to fixture via the DATA "IN" and DATA "OUT" XLR terminals located on all DMX fixtures (most controllers only have a DATA "OUT" terminal).

DMX Linking: DMX is a language allowing all makes and models of different manufactures to be linked together and operate from a single controller, as long as all fixtures and the controller are DMX compliant. *To ensure proper DMX data transmission, when using several DMX fixtures try to use the shortest cable path possible. The order in which fixtures are connected in a DMX line does not influence the DMX addressing. For example; a fixture assigned a DMX address of 1 may be placed anywhere in a DMX line, at the beginning, at the end, or anywhere in the middle. When a fixture is assigned a DMX address of 1, the DMX controller knows to send DATA assigned to address 1 to that unit, no matter where it is located in the DMX chain.*

Dipswitches in DMX mode: This unit uses dipswitches to assign a DMX address. Each dipswitch represents a binary value.

Dipswitch 1 address equals 1

Dipswitch 2 address equals 2

Dipswitch 3 address equals 4

Dipswitch 4 address equals 8

Dipswitch 5 address equals 16

Dipswitch 6 address equals 32

Dipswitch 7 address equals 64

Dipswitch 8 address equals 128

Dipswitch 9 address equals 256

Dipswitch 10 - Some units omit dipswitch 10. When a unit does include dipswitch #10, it is usually used for special functions such as

sound activation.

Assigning DMX Address: Each dipswitch has a preset value. A specific DMX address is set by combining the dipswitches that sum your desired value. For example: To achieve a DMX address of 7, combine dipswitches 1, 2, and 3. Since dipswitch 1 has a value of 1, dipswitch 2 has a value of 2, and dipswitch 3 has a value of 4, the combination of the three create a DMX value of 7. (See example below).

Set DMX address 1:	Set DMX address 7:
Dip-switches # 1 = 1	Dip-switches # 1 = 1
	2 = 2
	3 = 4
	= 7

Data Cable (DMX Cable) Requirements (For DMX and Master/Slave Operation): The Emerald Sky™ can be controlled via DMX-512 protocol. The Emerald Sky™ is a two channel DMX unit. The DMX address is set on the rear panel of the Emerald Sky™. Your unit and your DMX controller require a standard 3-pin XLR connector for data input and data output (Figure 1). If you are making your own cables, be sure to use standard two conductor shielded cable (This cable may be purchased at almost all pro sound and lighting stores). Your cables should be made with a male and female XLR connector on either end of the cable. Also remember that DMX cable must be daisy chained and can not be split.

Notice: Be sure to follow figures two and three when making your own cables. Do not use the ground lug on the XLR connector. Do not connect the cable's shield conductor to the ground lug or allow the shield conductor to come in contact with the XLR's outer casing. Grounding the shield could cause a short circuit and erratic behavior.

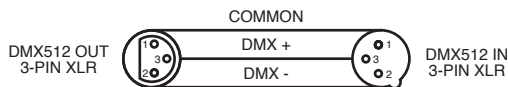

Figure 2

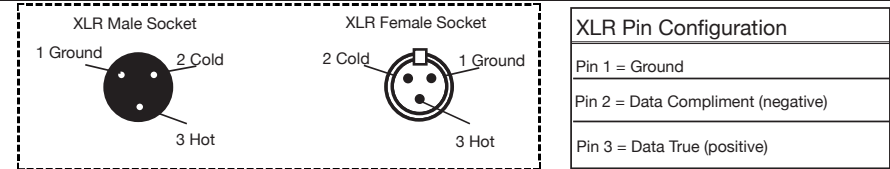

Figure 3

Special Note: Line Termination. When longer runs of cable are used, you may need to use a terminator on the last unit to avoid erratic behavior. A terminator is a 90-120 ohm 1/4 watt resistor which is connected between pins 2 and 3 of a male XLR connector (DATA + and DATA -). This unit is inserted in the female XLR socket of the last unit in your daisy chain to terminate the line. Using a cable terminator (ADJ part number Z-DMX/T) will decrease the possibilities of erratic behavior.

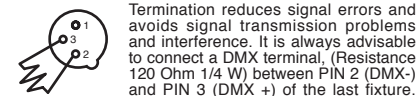

Figure 4

5-Pin XLR DMX Connectors. Some manufactures use 5-pin XLR connectors for DATA transmission in place of 3-pin. 5-pin XLR fixtures may be implemented in a 3-pin XLR DMX line. When inserting standard 5-pin XLR connectors in to a 3-pin line a cable adaptor must be used, these adaptors are readily available at most electric stores. The chart below details a proper cable conversion.

3-Pin XLR to 5-Pin XLR Conversion		
Conductor	3-Pin XLR Female (Out)	5-Pin XLR Male (In)
Ground/Shield	Pin 1	Pin 1
Data Compliment (- signal)	Pin 2	Pin 2
Data True (+ signal)	Pin 3	Pin 3
Not Used		Pin 4 - Do Not Use
Not Used		Pin 5 - Do Not Use

CAUTION IMPORTANT! When installing this projector, make sure that it is mounted in a manner that prevents the audience from looking directly into the beam, and the beam from striking the audience.

Power Supply: This unit is available only in 120v. Before plugging your unit in be sure the source voltage in your area matches the required voltage for your American DJ® Emerald Sky™.

General Operation: This fixture is designed to operate as a stand alone, sound-active unit, or in a Master/Slave configuration. It can also operate via DMX controller. Plug the unit into a wall outlet with the same matching voltage. Enter the power key into the back of the unit and turn it to the “On” position. Now put the power switch into the “On” position. The unit comes with several built-in patterns that automatically cycle through when the unit is operating, the patterns may not be selected manually. If the unit does not turn on after power is applied, be sure the fuse has not blown and the unit is properly plugged in to a matching wall outlet. If the problem continues to persist, please contact customer support for further instructions.

Sensitivity Knob: A sound sensitivity knob is located on the rear of the unit. Use this knob to regulate the amount of sound it takes to trigger the unit. Turning the knob in a clockwise direction will increase the units sensitivity to sound, turning the knob in a counterclockwise direction will decrease the units sensitivity. Turning the knob completely to the counter-clockwise direction will turn off the sound-active mode.

Operating Modes:

Universal DMX Control: This mode allows you to use a universal DMX-512 controller such as the American DJ® DMX Operator™ or Show Designer.™

1. To control your fixture in DMX mode, follow the set-up procedures on pages 10-12 as well as the set-up procedures included with your DMX controller.
2. For longer cable runs (more than a 100 feet) use a terminator on the last fixture.
3. Assign a DMX address to the unit by following DMX setup on pages 10-12.

4. The Emerald Sky™ uses two DMX channels. See page 16 for detailed description of the DMX traits. Use your DMX controller to activate the various built-in patterns.
5. For help operating in DMX mode consult the manual included with your DMX controller.

NOTE: If running in Master/Slave configuration while using a DMX controller, the Master unit should have dipswitch #11 set to the “On” position. All slave units should have dipswitch #1 set to the “ON” position.

Stand-Alone Operation (Auto Mode & Sound Active Mode):

This mode allows a single unit to run to the beat of the music. Only use this mode when running a single unit, or when running several units as individuals.

Auto Mode:

1. Set dipswitch #10 to the “On” position to activate Auto mode.

Sound Active Mode:

1. Set all dipswitches to the “Off” position to activate Stand-Alone.
2. The unit will react to the low frequencies of music via the internal microphone.
3. Use the audio sensitivity knob on the back of the unit to make the unit more or less sensitive to sound. Turning the sensitivity knob in the clockwise direction will increase the sensitivity, turning the knob in the counter-clockwise direction will decrease the fixture’s sensitivity to sound.

Master-Slave Operation (Auto Mode & Sound Active Mode):

This mode will allow you to link up to 16 units together and operate without a controller. In Master-Slave mode, the units will react to sound. In Master-Slave operation one unit will act as the controlling unit and the others will react to the controlling units programs. Any unit can act as a Master or as a Slave.

1. Using standard XLR microphone cables, daisy chain your units together via the XLR connector on the rear of the units. Remember the Male XLR connector is the input and the Female XLR connector is the output. For longer cable runs we suggest a terminator at the last fixture.
2. **Auto Mode:** Choose a unit to function as the Master and set

Emerald Sky™

Operation

dipswitches 10 & 11 to the “ON” position. This unit must be the first unit in line.

3. Turn dipswitch #1 to the “ON” position on the SLAVE units, and they will react the same as the MASTER.
4. **Sound Active Mode:** Choose a unit to function as the Master and set dipswitch #11 to the “ON” position. This unit must be the first unit in line.
5. Turn dipswitch #1 to the “ON” position on the SLAVE units, and they will react the same as the MASTER.
6. Use the sensitivity knob on the back of the master unit to make it more or less sensitive to sound.

Emerald Sky™

Fuse Replacement

Locate and remove the unit’s power cord. Once the cord has been removed locate the fuse holder located inside the power socket. Insert a flat-head screw driver into the power socket and gently pry out the fuse holder. Remove the bad fuse and replace with a new one. The fuse holder has a built-in socket for a spare fuse be sure not to confuse the spare fuse with active fuse.

Emerald Sky™

Cleaning

Due to fog residue, smoke, and dust, cleaning the internal lenses should be carried out periodically to optimize light output.

1. Use normal glass cleaner and a soft cloth to wipe down the outside casing.
2. Always be sure to dry all parts completely before plugging the unit back in.

Cleaning frequency depends on the environment in which the fixture operates (i.e. smoke, fog residue, dust, dew). In heavy use we recommend cleaning on a monthly basis. Periodic cleaning will ensure longevity, and crisp beam output.

Emerald Sky™

DMX Traits and Patterns

Channel	Value	Function
1		<u>LINE SELECTION</u>
	0	OFF
	1 - 52	LINE
	53 - 104	DOTTED LINE 1
	105 - 156	DOTTED LINE 2
	157 - 207	DOTTED LINE 3
	208 - 225 226 - 255	LINES CHANGE EVERY 3 SECONDS LINES CHANGE EVERY 5 SECONDS
2		LASER PATTERN SELECTION
		LEFT LASER RIGHT LASER
	0 - 1	STOP
	2 - 15	FAST FAST
	16 - 29	↑ MODERATE ↑ FAST
	30 - 43	↑ MODERATE ↑ MODERATE
	44 - 57	↑ FAST ↑ MODERATE
	58 - 71	FAST ↓ FAST
	72 - 85	↑ MODERATE ↓ FAST
	86 - 99	↑ MODERATE ↓ MODERATE
	100 - 113	↑ FAST ↓ MODERATE
	114 - 127	FAST ↓ FAST
	128 - 141	↓ MODERATE ↓ FAST
	142 - 155	↓ MODERATE ↓ MODERATE
	156 - 169	↓ FAST ↓ MODERATE
	170 - 183	FAST ↑ FAST
	184 - 197	↓ MODERATE ↑ FAST
198 - 211	↓ MODERATE ↑ MODERATE	
212 - 225	↓ FAST ↑ MODERATE	
226 - 255	SOUND ACTIVE MODE	

MANUFACTURER'S LIMITED WARRANTY

A. American DJ, Inc. hereby warrants, to the original purchaser, American DJ and American Audio products to be free of manufacturing defects in material and workmanship for a prescribed period from the date of purchase (see specific warranty period on reverse). This warranty shall be valid only if the product is purchased within the United States of America, including possessions and territories. It is the owner's responsibility to establish the date and place of purchase by acceptable evidence, at the time service is sought.

B. For warranty service you must obtain a Return Authorization number (RA#) before sending back the product. Contact American DJ, Inc. Service Department at 800-322-6337. Send the product only to the American DJ, Inc. factory. All shipping charges must be pre-paid. If the requested repairs or service (including parts replacement) are within the terms of this warranty, American DJ, Inc. will pay return shipping charges only to a designated point within the United States. If the entire instrument is sent, it must be shipped in its original package. No accessories should be shipped with the product. If any accessories are shipped with the product, American DJ, Inc. shall have no liability whatsoever for loss of or damage to any such accessories, nor for the safe return thereof.

C. This warranty is void if the serial number has been altered or removed; if the product is modified in any manner which American DJ, Inc. concludes, after inspection, affects the reliability of the product; if the product has been repaired or serviced by anyone other than the American DJ, Inc. factory unless prior written authorization was issued to purchaser by American DJ, Inc.; if the product is damaged because not properly maintained as set forth in the instruction manual.

D. This is not a service contract, and this warranty does not include maintenance, cleaning or periodic check-up. During the period specified above, American DJ, Inc. will replace defective parts at its expense with new or refurbished parts, and will absorb all expenses for warranty service and repair labor by reason of defects in material or workmanship. The sole responsibility of American DJ, Inc. under this warranty shall be limited to the repair of the product, or replacement thereof, including parts, at the sole discretion of American DJ. All products covered by this warranty were manufactured after January 1, 1990, and bear identifying marks to that effect.

E. American DJ, Inc. reserves the right to make changes in design and/or improvements upon its products without any obligation to include these changes in any products theretofore manufactured. No warranty, whether expressed or implied, is given or made with respect to any accessory supplied with products described above. Except to the extent prohibited by applicable law, all implied warranties made by American DJ, Inc. in connection with this product, including warranties of merchantability or fitness, are limited in duration to the warranty period set forth above. And no warranties, whether expressed or implied, including warranties of merchantability or fitness, shall apply to this product after said period has expired. The consumer's and/or Dealer's sole remedy shall be such repair or replacement as is expressly provided above; and under no circumstances shall American DJ, Inc. be liable for any loss or damage, direct or consequential, arising out of the use of, or inability to use, this product.

This warranty is the only written warranty applicable to American DJ and American Audio Products and supersedes all prior warranties and written descriptions of warranty terms and conditions heretofore published.

MANUFACTURER'S LIMITED WARRANTY PERIODS:

- All American Audio Products = 1-year (365 day) Limited Warranty (except V-Plus Series Amplifiers)
- All American Audio V-Plus Series Amplifiers = 3-year (1095 day) Limited Warranty
- American DJ Lighting and American DJ Branded Products = 1-year (365 day) Limited Warranty (Such as: Special Effect Lighting, Intelligent Lighting, UV lighting, Strobos, Fog Machines, Bubble Machines, Mirror Balls, Par Cans, Trussing, Lighting Stands etc. excluding Laser Products, lamps, and Star Tec Series)
- American DJ Laser Products and Star Tec Products = 90-Day Limited Warranty
- American DJ L.E.D. Products = 3-year (1095 day) Limited Warranty (excluding motors which have a 1-year (365 day) Limited Warranty)

Model: Emerald Sky™

Voltage:	120v~60Hz
Laser:	4.9mW Green
Fuse:	2A
Dimensions:	7.0" (L) x 12.5" (W) x 8.0" (H)
Weight:	8 Lbs./ 3.0 Kgs.
Duty Cycle:	None
Warranty:	90 Days

Please Note: Specifications and improvements in the design of this unit and this manual are subject to change without any prior written notice.

American DJ®
American DJ World Headquarters:
6122 S. Eastern Ave. Los Angeles, CA 90040 USA
Tel: 323-582-2650 / Fax: 323-725-6100
Web: www.americandj.com / E-mail: info@americandj.com