

American DJ®

GP 250



User Instructions

American DJ®
4295 Charter Street
Los Angeles CA. 90058
www.americandj.com

Rev. 6/06

GP 250™

General Information

Unpacking: Thank you for purchasing the GP 250™ by American DJ®. Every GP 250™ has been thoroughly tested and has been shipped in perfect operating condition. Carefully check the shipping carton for damage that may have occurred during shipping. If the carton appears to be damaged, carefully inspect your fixture for any damage and be sure all equipment necessary to operate the unit has arrived intact. In the event damage has been found or parts are missing, please contact our toll free customer support number for further instructions. Please do not return this unit to your dealer without contacting customer support first.

Introduction: The GP 250™ is a four channel, intelligent DMX fixture, that creates a bright, and awesome ambient effect, using multiple colored gobos. The fixture can operate in three different operating modes; stand alone, sound-active, or in a Master/Slave configuration. The GP 250™ comes with several built in programs and is best used in multiples of four. When used as a stand alone unit or when used in multiples linked in a master/slave configuration. *For best results use fog or special effects smoke to enhance the beams projections.*

Customer Support: American DJ® provides a toll free customer support line, to provide help and to answer any question should you encounter problems during your set up or initial operation. You may also visit us on the web at www.americandj.com for any comments or suggestions. Service Hours are Monday through Friday 9:00 a.m. to 5:00 p.m. Pacific Standard Time.

Voice: (800) 322-6337

Fax: (323) 582-2610

E-mail: support@americandj.com

To purchase parts online visit <http://parts.americandj.com>

Warning! To prevent or reduce the risk of electrical shock or fire, do not expose this unit to rain or moisture.

Warning! *This may cause severe eye damage. Avoid looking directly into the light source at all times!*

For Your Own Personal Safety, Please Read and Understand This Manual Completely Before You Attempt To Install Or Operate This Unit!

- To reduce the risk of electrical shock or fire, do not expose this unit rain or moisture
- Do not spill water or other liquids into or on to your unit.
- Be sure that the local power outlet match that of the required voltage for your unit.
- Do not attempt to operate this unit if the power cord has been frayed or broken.
- Do not attempt to remove or break off the ground prong from the electrical cord. This prong is used to reduce the risk of electrical shock and fire in case of an internal short.
- Disconnect from main power before making any type of connection.
- Do not remove the cover under any conditions. There are no user serviceable parts inside.
- Never operate this unit when it's cover is removed.
- Always be sure to mount this unit in an area that will allow proper ventilation. Allow about 6" (15cm) between this device and a wall.
- Do not attempt to operate this unit, if it becomes damaged.
- This unit is intended for indoor use only, use of this product outdoors voids all warranties.
- Always mount this unit in safe and stable matter.
- Power-supply cords should be routed so that they are not likely to be walked on or pinched by items placed upon or against them, paying particular attention to cords at plugs, convenience receptacles, and the point where they exit from the appliance.
- Cleaning -The fixture should be cleaned only as recommended by the manufacturer. See page 18 for cleaning details.
- Heat -This fixture should be situated away from heat sources such as radiators, heat registers, stoves, or other appliances (including amplifiers) that produce heat.
- The fixture should be serviced by qualified service personnel when:
 - A. Objects have fallen, or liquid has been spilled into the appliance.
 - B. The appliance has been exposed to rain or water.
 - C. The appliance does not appear to operate normally or exhibits a marked change in performance.

Caution! There are no user serviceable parts inside this unit. Do not attempt any repairs yourself, doing so will void your manufactures warranty. In the unlikely event your unit may require service please contact American DJ®.

During operation the housing may become extremely hot. Avoid touching the unit with bare hands while in use.

American DJ® will not accept any liability for any resulting damages caused by the non-observance of this manual or any unauthorized modification to this unit.

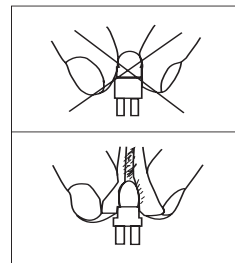

This fixture is fitted with a halogen lamp which is highly susceptible to damage if improperly handled. Never touch the lamp with your bare fingers as the oil from your hands will shorten lamp life. Also, never move the fixture until the lamps have had ample time to cool. Remember, lamps are not covered under warranty conditions.

Caution: Always replace with the exact same type lamp, unless otherwise specified by an authorized American DJ® technician. Replace with anything other than the specified part can damage your unit and will void your manufactures warranty.

Warning: If after you have replaced the lamp or reset the breaker and you continue to blow either one, STOP using the unit. Contact customer support for further instructions, you may have to return the unit for servicing. Continuing to use the unit may cause serious damage.

To optimize the performance of this product, please read these operating instructions carefully to familiarize yourself with the basic operations of this unit. These instructions contain important safety information regarding the use and maintenance of this unit. Please keep this manual with the unit, for future reference.

The GP 250™ carries a one year limited warranty. Please fill out the enclosed warranty card to validate your purchase. All returned service items whether under warranty or not, must be freight pre-paid and accompany a return authorization (R.A.) number. The R.A. number must be clearly written on the outside of the return package. A brief description of the problem as well as the R.A. number must also be written down on a piece of paper and included in the shipping carton. If the unit is under warranty, you must provide a copy of your proof of purchase invoice. You may obtain a R.A. number by contacting our customer support team on our toll free customer support number. All packages returned to the service department not displaying a R.A. number on the outside of the package will be returned to the shipper at the shippers cost.

- Micro-Stepping Motors
- DMX-512 Protocol Compatible (Uses Four DMX Channels)
- 3 Operating Modes - Master/Slave; Stand Alone; Sound Active
- Colored Gobo Wheel
- Internal Microphone
- ZB-EHJ5 24V/250W
- Manual Focus Lens
- Mini/C Input Jack for Blackout Function
(Mini/C Controller Not Included)

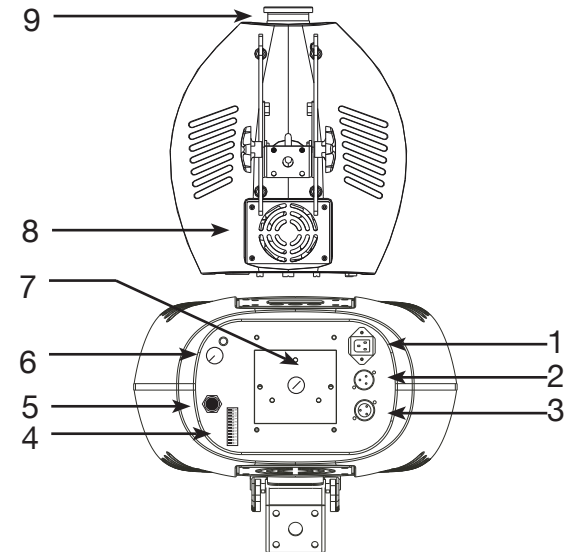

1. Power Cord Inlet and Fuse Holder

Power Cord Inlet - This unit is equipped with a removable I.E.C. power cord. Be sure to only use the power cord included with the unit, this cord is designed to match the electrical requirements of the unit. Other cords may cause the unit to overheat or malfunction. Voltage may vary from venue to venue, when connecting this unit to a power supply be sure to connect to a matching power outlet. Never use this fixture if the ground prong has been removed or broken off. The ground prong is designed to reduce the risk of fire or electrical shock in the event the unit suffers from an internal short.

Fuse Holder - This housing stores a 8 amp (4 amp 220v) GMA protective fuse. Never defeat the fuse, the fuse is designed to protect the electronics in the event of severe power fluctuations. Always be sure to replace the fuse with an exact match as the one being replaced, unless otherwise told to do so by an authorized American DJ® service technician.

2. XLR Output Jack - This jack is used to transmit the incoming DMX signal to another DMX fixture, or transmit a Master/Slave signal to the next GP 250™ in the chain. For best results in DMX or Master/Slave mode terminate this jack if it is the last unit in the chain. See “Terminator” on page 10.

3. XLR DMX Input Jack - This jack is used to receive an incoming DMX signal or Master/Slave signal.

4. Dipswitches - These switches serve two functions. In master-slave mode these switches are used to assign a specific head address. In DMX mode these switches are used to assign a DMX address to the unit. In DMX mode each switch corresponds to a specific value based on binary code. See pages 8-10 for a detailed explanation of DMX binary code.

5. Audio Sensitivity Knob - This will adjust the audio sensitivity of the INTERNAL MICROPHONE. Turning the sensitivity knob in the clockwise direction will increase the sensitivity to sound. Turning the knob in the counter clockwise direction will decrease the fixture's sensitivity to sound.

6. MINI/C Controller Jack - This jack is for use with the optional MINI/C controller only. This controller is used to control the blackout function. Do not attempt to connect an audio signal to this jack, this will damage the PC board and void your manufacturer's warranty!

7. Lamp Assembly and Access Plate - This plate accesses the lamp socket assembly. The unit includes a spring mounted ZB-EHJ5 250w halogen lamp. Be sure to only replace with same type lamp. After replacing a lamp be sure the lamp is centered in the reflector. See pages 13-14 for details on installing and optimizing replacement lamps. Never operate this unit with the lamp exposed, this lamp emits strong UV radiation.

8. Cooling Fan - This unit is equipped with two high velocity variable fans to aid in the cooling process. These fans are designed to vary their velocity at different operating temperatures, to provide better cooling when the unit reached higher operating temperatures associated with long usage. Be sure to never obstruct the cooling fans during normal usage. Also, be sure to keep the vents clean at all times. A blocked or malfunctioning cooling system may shorten lamp life and unit reliability.

9. Lens Assembly - This high quality lens is a fully focusing. Focus the lens by manually turning the lens in a clockwise or counter-clockwise direction until the desired effect is achieved.

Power Supply: Before plugging your unit in, be sure the source voltage in your area matches the required voltage for your American DJ® GP 250.™ The American DJ® GP 250™ is available in a 120v and 220v version. Because line voltage may vary from venue to venue, you should be sure your unit voltages matches the wall outlet voltage before attempting to operate you fixture.

DMX-512: *DMX is short for Digital Multiplex. This is a universal protocol used as a form of communication between intelligent fixtures and controllers. A DMX controller sends DMX data instructions from the controller to the fixture. DMX data is sent as serial data that travels from fixture to fixture via the DATA "IN" and DATA "OUT" XLR terminals located on all DMX fixtures (most controllers only have a DATA "OUT" terminal).*

DMX Linking: DMX is a language allowing all makes and models of different manufactures to be linked together and operate from a single controller, as long as all fixtures and the controller are DMX compliant. *To ensure proper DMX data transmission, when using several DMX fixtures try to use the shortest cable path possible. The order in which fixtures are connected in a DMX line does not influence the DMX addressing. For example; a fixture assigned a DMX address of 1 may be placed anywhere in a DMX line, at the beginning, at the end, or anywhere in the middle. When a fixture is assigned a DMX address of 1, the DMX controller knows to send DATA assigned to address 1 to that unit, no matter where it is located in the DMX chain.*

Dip-switches in DMX mode: This unit uses dip switches to assign a DMX address. Each dip switch represents a binary value.

Dip Switch 1 address equals 1

Dip Switch 2 address equals 2

Dip Switch 3 address equals 4

Dip Switch 4 address equals 8

Dip Switch 5 address equals 16

Dip Switch 6 address equals 32

Dip Switch 7 address equals 64

Dip Switch 8 address equals 128

Dip Switch 9 address equals 256

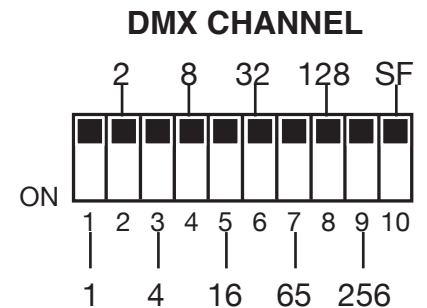

Dipswitches 10, 11, and 12 - Some units omit dipswitch 10, and most units do not have dipswitches 11 and 12. When a unit does include

dipswitch 10 it is usually used for special functions such as sound activation.

Each dip switch has a preset value. A specific DMX address is set by combining the dip switches that sum your desired value. For example: To achieve a DMX address of 21, combine dip switches 1, 3, and 5. Sense dip switch 1 has a value of 1, dip switch 3 has a value of 4, and dip switch 5 has a value of 16, the combination of the create a DMX value of 21.

Set DMX address 21:	Set DMX address 201:
Dip-switches # 1 = 1	Dip-switches # 1 = 1
3 = 4	4 = 8
5 = 16	7 = 64
= 21	8 = 128
	= 201

Data Cable (DMX Cable) Requirements (For DMX and Master/Slave Operation):

The GP 250™ can be controlled via DMX-512 protocol. The GP 250™ is a four channel DMX unit. The DMX address is set on the bottom panel of the GP 250™. Your unit and your DMX controller require a standard 3-pin XLR connector for data input and data output (Figure 1). If you are making your own cables, be sure to use standard two conductor shielded cable (This cable may be purchased at almost all pro sound and lighting stores). Your cables should be made with a male and female XLR connector on either end of the cable. Also remember that DMX cable must be daisy chained and can not be split.



Figure 1

Notice: Be sure to follow figures two and three when making your own cables. Do not use the ground lug on the XLR connector. Do not connect the cable's shield conductor to the ground lug or allow the shield conductor to come in contact with the XLR's outer casing. Grounding the shield could cause a short circuit and erratic behavior.

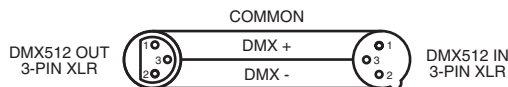

Figure 2

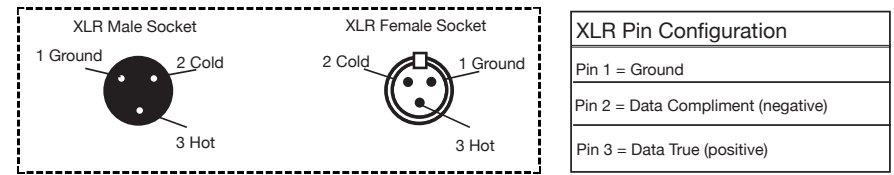

Figure 3

Special Note: Line Termination. When longer runs of cable are used, you may need to use a terminator on the last unit to avoid erratic behavior. A terminator is a 90-120 ohm 1/4 watt resistor which is connected between pins 2 and 3 of a male XLR connector (DATA + and DATA -). This unit is inserted in the female XLR connector of the last unit in your daisy chain to terminate the line. Using a cable terminator (ADJ part number Z-DMX/T) will decrease the possibilities of erratic behavior.



Termination reduces signal errors and avoids signal transmission problems and interference. It is always advisable to connect a DMX terminal, (Resistance 120 Ohm 1/4 W) between PIN 2 (DMX-) and PIN 3 (DMX +) of the last fixture.

Figure 4

5-Pin XLR DMX Connectors. Some manufactures use 5-pin XLR connectors for DATA transmission in place of 3-pin. 5-pin XLR fixtures may be implemented in a 3-pin XLR DMX line. When inserting standard 5-pin XLR connectors in to a 3-pin line a cable adaptor must be used, these adaptors are readily available at most electric stores. The chart below details a proper cable conversion.

3-Pin XLR to 5-Pin XLR Conversion		
Conductor	3-Pin XLR Female (Out)	5-Pin XLR Male (In)
Ground/Shield	Pin 1	Pin 1
Data Compliment (- signal)	Pin 2	Pin 2
Data True (+ signal)	Pin 3	Pin 3
Not Used		Pin 4 - Do Not Use
Not Used		Pin 5 - Do Not Use

Operating Modes: The GP 250™ can operate in three different modes. This next section will detail the differences in the operating modes.

• **Stand alone mode -**

The unit will react to sound, chasing through the built-in programs. You can also use the optional MINI/C Remote Control to blackout the units.

• **Master/Slave mode -**

You can daisy chain up to 16 units together to get a synchronized light show without the need of an external controller. The units will react to sound chasing through the several built-in programs.

• **DMX control mode -**

This function will allow you to control each individual fixtures traits with a standard DMX-512 controller such as the Elation® Show Designer™.

Universal DMX Control: This function allows you to use a universal DMX-512 controller such as the Elation® DMX Operator™ or Elation® Show Designer™ to control the colored gobo wheel, the shutter (strobe), and the Internal programs. A DMX controller allows you to create unique programs tailored to your individual needs.

1. The GP 250™ uses four DMX channels. Channel 1 controls the colored gobo wheel, channel 2 controls the gobo rotation, channel 3 controls the dimmer, and channel 4 selects one of the 8 internal programs. See page 16 for a detailed description of the DMX traits.
2. To control your fixture in DMX mode, follow the set-up procedures on pages 8-10 as well as the set-up specifications that are included with your DMX controller.
3. Use the controller's faders to control the various DMX fixture traits.
4. This will allow you to create your own programs.
5. For longer cable runs (more than a 100 feet) use a terminator on the last fixture.
6. For more help operating in DMX mode consult the manual included with your DMX controller.

Stand-Alone Operation (Sound Active): This mode allows a single unit or several units linked together, to run to the beat of the

music.

1. To operate the unit in Sound Active mode. Set dipswitch #10 and #11 to the "on" position. See dipswitch settings on page 15.
2. The GP 250™ will now react to the bass sound of music via the internal microphone.

Stand Alone Mode (Internal Program):

1. To operate as a stand alone unit, via its internal program, follow the dipswitch settings on page 15.
2. The GP 250™ will now run its own internal program.
3. You can also use the optional MINI/C Remote Control to activate the blackout function.

Master-Slave Operation: This function will allow you to link up to 16 units together and operate without a controller. The units can be sound activate or run the Internal program. In Master-Slave operation one unit will act as the controlling unit and the others will react to the controlling units movements and programs. Any unit can act as a Master or as a Slave.

1. Using standard XLR microphone cables, daisy chain your units together via the XLR connector on the rear of the units. Remember the Male XLR connector is the input and the Female XLR connector is the output. The first unit in the chain (master) will use the female XLR connector only - The last unit in the chain will use the male XLR connector only. For longer cable runs we suggest a terminator at the last fixture.
2. For dipswitch settings on setting the Master and Slave, and also the modes of operation, i.e. sound active, internal programs, see page 15.
5. You can also use the optional MINI/C Remote Control to activate the blackout function. If you want to use the optional remote control, connect the MINI/C controller to the first fixture in the line (master)

Caution: Always replace with the exact same type lamp and fuse, unless otherwise specified by an authorized American DJ® service technician. Replacing with anything other than the specified part can damage your unit and will void your manufacturer's warranty.

Warning: If you continue to blow lamps or fuses, STOP using the unit. Contact customer support for further instructions, you may have to return the unit for servicing. Continuing to use the unit may cause serious damage.

Lamp Replacement: Caution! Never attempt to change the lamp while the fixture is plugged in. Always disconnect the main power and allow the unit ample time to cool before attempting to replace the lamp. Lamp replacement has been made simple by incorporating a slide out lamp assembly that is retained by two phillips screws.

1. Be sure to follow the proper handling procedures that deal with discharge lamps.
2. Unscrew the two thumb screws (A,B) on the rear of the unit
3. After removing the screws, gently slide out the socket assembly from the rear of the unit to expose the lamp.
4. Carefully remove the old lamp and discard it in the trash.
5. Replace the lamp with an exact match and reassemble in reverse order.
6. After replacing the lamp follow the optimization procedures on the next page to be sure the lamp is center in the reflector

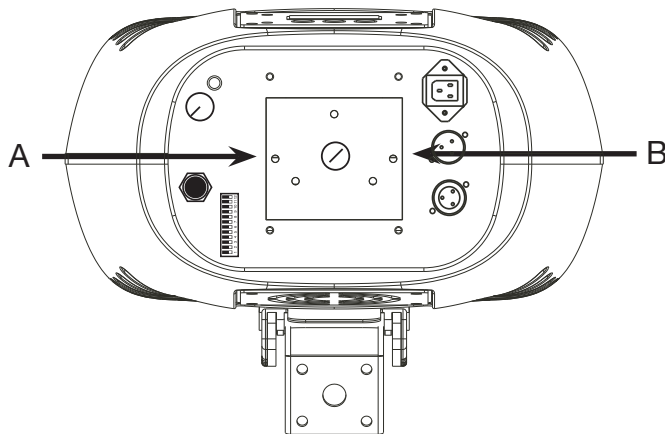

Optimizing Lamp Alignment: This procedure centers the lamp in the reflector. Proper optimization will increase lamp life and ensure a bright crisp output. Improper optimization may add a yellow tint to the lamp output and reduce intensity.

1. Be sure main power is disconnected and allow the unit to cool. If the you have just installed a new unit you can obviously skip this step.
2. Make a preliminary adjustment: Turn the three lamp adjustment thumb screws completely in (clockwise). Then back them each out (counter-clockwise) about three complete turns.
3. Turn the unit on and allow it to reset.
4. Using either a DMX controller or the control panel on the unit, strike the lamp and focus the light on a flat surface.
5. Center the hot-spot (the brightest part of the beam) using the 3 adjustment screws. Turn one screw at a time to drag the hot-spot diagonally across the projected image. If you cannot detect a hot-spot, adjust the lamp until the light is even.
6. To reduce a hot-spot, pull the lamp in by turning all three screws clockwise 1/4-turn at a time until the light is evenly distributed.
7. If the light is brighter around the edge than it is in the center, or if light output is low, the lamp is too far back in the reflector. "Push" the lamp out by turning the screws.

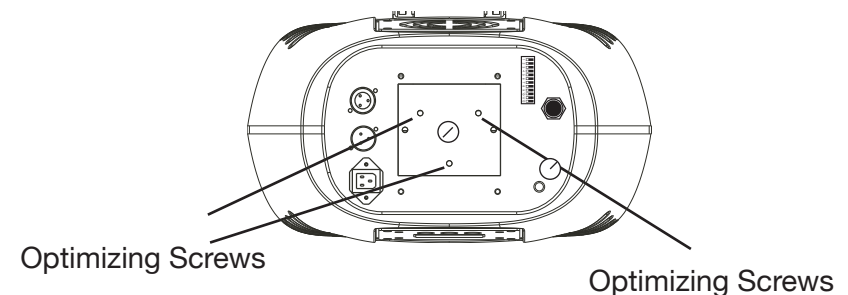

Fuse Replacement: Locate and remove the unit's power cord. Once the cord has been removed located the fuse holder located inside the power socket. Insert a flat-head screw driver into the power socket and gently pry out the fuse holder. Remove the bad fuse and replace with a new one. The fuse holder has a built-in socket for a spare fuse be sure not to confuse the spare fuse with active fuse.

GP 250™ Dipswitch Settings

Switch Status													0=off 1=on		
VALUE											FUNCTION BIT				
DEC	DP1	DP2	DP3	DP4	DP5	DP6	DP7	DP8	DP9	DP10	DP11	DP12			
x	x	x	x	x	x	x	x	x	x	x	x	x	1	Terminal	
DMX ADDR SET											0	0	0	Normal	
x	x	x	x	x	x	x	x	x	x	x	0	1	0	Slave	
x	x	x	x	x	x	x	x	x	x	x	1	1	0	AloneSound	
MasterMode															
0	0	0	0	0	0	0	0	0	0	0	1	0	0	Sound Active	
1	1	0	0	0	0	0	0	0	0	0	1	0	0	Gobo1	
2	0	1	0	0	0	0	0	0	0	0	1	0	0	Gobo2	
3	1	1	0	0	0	0	0	0	0	0	1	0	0	Gobo3	
4	0	0	1	0	0	0	0	0	0	0	1	0	0	Gobo4	
5	1	0	1	0	0	0	0	0	0	0	1	0	0	Gobo5	
6	0	1	1	0	0	0	0	0	0	0	1	0	0	Gobo 1 shake	
7	1	1	1	0	0	0	0	0	0	0	1	0	0	Gobo 2 shake	
8	0	0	0	1	0	0	0	0	0	0	1	0	0	Gobo 3 shake	
9	1	0	0	1	0	0	0	0	0	0	1	0	0	Gobo 4 shake	
10	0	1	0	1	0	0	0	0	0	0	1	0	0	Gobo 5 shake	
11	1	1	0	1	0	0	0	0	0	0	1	0	0	Gobo 1 shake slow	
12	0	0	1	1	0	0	0	0	0	0	1	0	0	Gobo 1 shake fast	
13	1	0	1	1	0	0	0	0	0	0	1	0	0	Gobo wheel rotation Slow	
14	0	1	1	1	0	0	0	0	0	0	1	0	0	Gobo wheel rotation Fast	
16	0	0	0	0	1	0	0	0	0	0	1	0	0	Internal program 1	
17	1	0	0	0	1	0	0	0	0	0	1	0	0	Internal program 2	
18	0	1	0	0	1	0	0	0	0	0	1	0	0	Internal program 3	
19	1	1	0	0	1	0	0	0	0	0	1	0	0	Internal program 4	
20	0	0	1	0	1	0	0	0	0	0	1	0	0	Internal program 5	
21	1	0	1	0	1	0	0	0	0	0	1	0	0	Internal program 6	
22	0	1	1	0	1	0	0	0	0	0	1	0	0	Internal program 7	
23	1	1	1	0	1	0	0	0	0	0	1	0	0	Internal program 8	

GP 250™ DMX Traits

Channel	Value	Function	
1 ↓	0 - 17	<u>COLORED GOBO WHEEL</u> CLOSED	
	18 - 35	GOBO 1	
	36 - 53	GOBO 2	
	54 - 71	GOBO 3	
	72 - 89	GOBO 4	
	90 - 111	GOBO 5	
	112 - 127	GOBO 1 SHAKE SLOW - FAST	
	128 - 143	GOBO 2 SHAKE SLOW - FAST	
	144 - 159	GOBO 3 SHAKE SLOW - FAST	
	160 - 175	GOBO 4 SHAKE SLOW - FAST	
	176 - 190	GOBO 5 SHAKE SLOW - FAST	
	191 - 255	GOBO WHEEL ROTATION SLOW - FAST	
	2	0 - 7	<u>GOBO ROTATION</u> NO ROTATION
		8 - 255	ROTATION
3	0 - 255	<u>DIMMER</u> INTENSITY 0 - 100%	
4 ↓	0 - 39	<u>BUILT-IN PROGRAMS</u> NORMAL	
	40 - 99	ALL MOTOR RESET	
	100 - 119	AUTO PROGRAM 1	
	120 - 139	AUTO PROGRAM 2	
	140 - 159	AUTO PROGRAM 3	
	160 - 179	AUTO PROGRAM 4	
	180 - 199	AUTO PROGRAM 5	
	200 - 219	AUTO PROGRAM 6	
	220 - 239	AUTO PROGRAM 7	
	240 - 255	AUTO PROGRAM 8	

This unit comes with interchangeable gobos. Changing the gobos is a easy procedure. Follow the instructions below.

Caution! *Never open the unit when in use. Always disconnect the main power before attempting to change the gobos.*

1. To change the gobo, you must remove the top half of the unit.
2. First unscrew the four phillips screws on the top half of the shell. Remove the top half of the shell.
3. When you remove the top shell you will be able to access the colored gobo wheel. Turn the wheel with your hand until you come across the gobo you would like to change.
4. Remove the fixation-ring with a small flat-head screwdriver. Push the gobo out towards the rear. When doing this you do not need a lot of pressure.
5. Change the gobo, replace the fixation-ring, and reassemble the unit.

Fixture Cleaning: Due to fog residue, smoke, and dust cleaning the internal and external optical lenses and mirror should be carried out periodically to optimize light output. Cleaning frequency depends on the environment in which the fixture operates (I.e. smoke, fog residue, dust, dew). In heavy club use we recommend cleaning on a monthly basis. Periodic cleaning will ensure longevity, and crisp output.

1. Use normal glass cleaner and a soft cloth to wipe down the outside casing.
2. Use a brush to wipe down the cooling vents and fan grill.
3. Clean the external optics and mirror with glass cleaner and a soft cloth every 20 days.
4. Clean the internal optics with glass cleaner and a soft cloth every 30-60 days.
5. Always be sure to dry all parts completely before plugging the unit back in.

Trouble Shooting: Listed below are a few common problems that you may encounter, with solutions.

No light output from the unit;

1. Be sure you have connected your unit into a standard 120v wall outlet.
2. Be sure the external fuse has not blown. The fuse is located on the back panel of the unit inside the power socket.
3. Remove the lamp holder and be sure the lamp is seated in its socket properly. Occasionally lamps become loose during shipping be sure the lamp is push in to its socket all the way.
4. Be sure the fuse holder is completely and properly seated.

Unit does not respond to sound;

1. Low frequencies (bass) should cause the unit to react to sound. Tapping on the microphone, quiet or high pitched sounds may not activate the unit.

1-YEAR LIMITED WARRANTY

A. American DJ® hereby warrants, to the original purchaser, American DJ® products to be free of manufacturing defects in material and workmanship for a period of 1 Year (365 days) from the date of purchase. This warranty shall be valid only if the product is purchased within the United States of America, including possessions and territories. It is the owner's responsibility to establish the date and place of purchase by acceptable evidence, at the time service is sought.

B. For warranty service, send the product only to the American DJ® factory. All shipping charges must be pre-paid. If the requested repairs or service (including parts replacement) are within the terms of this warranty, American DJ® will pay return shipping charges only to a designated point within the United States. If the entire instrument is sent, it must be shipped in its original package. No accessories should be shipped with the product. If any accessories are shipped with the product, American DJ® shall have no liability whatsoever for loss of or damage to any such accessories, nor for the safe return thereof.

C. This warranty is void if the serial number has been altered or removed; if the product is modified in any manner which American DJ® concludes, after inspection, affects the reliability of the product; if the product has been repaired or serviced by anyone other than the American DJ® factory unless prior written authorization was issued to purchaser by American DJ®; if the product is damaged because not properly maintained as set forth in the instruction manual.

D. This is not a service contract, and this warranty does not include maintenance, cleaning or periodic check-up. During the period specified above, American DJ® will replace defective parts at its expense, and will absorb all expenses for warranty service and repair labor by reason of defects in material or workmanship. The sole responsibility of American DJ® under this warranty shall be limited to the repair of the product, or replacement thereof, including parts, at the sole discretion of American DJ®. All products covered by this warranty were manufactured after January 1, 1990, and bear identifying marks to that effect.

E. American DJ® reserves the right to make changes in design and/or improvements upon its products without any obligation to include these changes in any products theretofore manufactured.

F. No warranty, whether expressed or implied, is given or made with respect to any accessory supplied with products described above. Except to the extent prohibited by applicable law, all implied warranties made by American DJ® in connection with this product, including warranties of merchantability or fitness, are limited in duration to the warranty period set forth above. And no warranties, whether expressed or implied, including warranties of merchantability or fitness, shall apply to this product after said period has expired. The consumer's and or Dealer's sole remedy shall be such repair or replacement as is expressly provided above; and under no circumstances shall American DJ® be liable for any loss or damage, direct or consequential, arising out of the use of, or inability to use, this product.

G. This warranty is the only written warranty applicable to American DJ® Products and supersedes all prior warranties and written descriptions of warranty terms and conditions heretofore published.

H. Lamps are not covered under this or any other warranty, either written or implied.

Model:	GP 250™
Voltage*:	120v/60Hz or 230v/50Hz
Lamp:	ZB-EHJ5 24v/250w
Dimensions:	12.7"(L) x 11.5"(W) x 8.7"(H) 325mm x 301mm x 223mm
Weight:	22 Lbs. / 10 kgs.
Gobos:	5
Gobo Size:	32mm
Viewable Gobo Size:	27mm
Fuse:	8A (120v) / 4A (220v)
Duty Cycle:	None
DMX:	4 Channels
Sound Active:	Yes
Working Position:	Any Safe, Secure Position
Warranty:	1 Year (365 days)

*Voltage is preset at the factory and is not user selectable

Please Note: Specifications and improvements in the design of this unit and this manual are subject to change without any prior written notice.

American DJ®
 American DJ World Headquarters:
 4295 Charter Street Los Angeles, CA 90058 USA
 Tel: 323-582-2650 / Fax: 323-582-2610
 Web: www.americandj.com / E-mail: info@americandj.com