

# American DJ®

## ROLLER TRON 250



## User Instructions

American DJ®  
4295 Charter Street  
Los Angeles CA. 90058  
[www.americandj.com](http://www.americandj.com)

Rev. 12/06

### RollerTron 250™

### General Information

**Unpacking:** Thank you for purchasing the RollerTron 250™ by American DJ®. Every RollerTron 250™ has been thoroughly tested and has been shipped in perfect operating condition. Carefully check the shipping carton for damage that may have occurred during shipping. If the carton appears to be damaged, carefully inspect your fixture for any damage and be sure all equipment necessary to operate the unit has arrived intact. In the event damage has been found or parts are missing, please contact our toll free customer support number for further instructions. Please do not return this unit to your dealer without first contacting customer support.

**Introduction:** This unit is five channel DMX intelligent scanner with a unique barrel mirror that may be easily converted to an intelligent color changer by removing the mirror unit. This unit can also run as a stand alone, sound-active unit, or in a Master/Slave configuration as either a scanner or color changer. The RollerTron 250™ comes with three built in programs and is best used in multiples of four. When used as a stand alone unit or when used in multiples linked in a master/slave configuration the optional Mini/C or Wireless/C controller may be used. The optional controller will access different programs and control a blackout function. *For best results use fog or special effects smoke to enhance the beams projections.*

**Customer Support:** American DJ® provides a toll free customer support line, to provide set up help and to answer any question should you encounter problems during your set up or initial operation. You may also visit us on the web at [www.americandj.com](http://www.americandj.com) for any comments or suggestions. Service Hours are Monday through Friday 9:00 a.m. to 5:00 p.m. Pacific Standard Time.

Voice: (800) 322-6337

Fax: (323) 582-2610

E-mail: [support@americandj.com](mailto:support@americandj.com)

To purchase parts online visit <http://parts.americandj.com>

**Warning!** To prevent or reduce the risk of electrical shock or fire, do not expose this unit to rain or moisture.

**Caution!** There are no user serviceable parts inside this unit. Do not attempt any repairs yourself, doing so will void your manufactures warranty. In the unlikely event your unit may require service please contact American DJ®.

To optimize the performance of this product, please read these operating instructions carefully to familiarize yourself with the basic operations of this unit. These instructions contain important safety information regarding the use and maintenance of this unit. Please keep this manual with the unit, for future reference.

The RollerTron 250™ carries a one year limited warranty. Please fill out the enclosed warranty card to validate your purchase. All returned service items whether under warranty or not, must be freight pre-paid and accompany a return authorization (R.A.) number. The R.A. number must be clearly written on the outside of the return package. A brief description of the problem as well as the R.A. number must also be written down on a piece of paper included in the shipping carton. If the unit is under warranty, you must provide a copy of your proof of purchase invoice. You may obtain a R.A. number by contacting our customer support team on our toll free customer support number. All packages returned to the service department not displaying a R.A. number on the outside of the package will be returned to the shipper.

- Micro-Stepping Motors for Smooth Color and Gobo Transitions
- DMX-512 Protocol Compatible (Uses Five DMX Channels)
- Bright Lamp ZB-ELC10 24v/250w
- 10 Gobo Patterns Plus One Spot/6 Colors Plus White and 1 Quad Color
- Master/Slave Operation
- 3 Programmed Light Shows; A Big Angle Program for Large Dance Floors, A Small Angle Program for Small Dance Floors and One Free Angle Program
- Fast X/Y Mirror Speed for High Energy Music
- Internal Microphone with Volume Sensitivity Knob
- Removable Head for Color Changer Operation
- Mirror Shield to Protect the Mirror during Transportation
- Variable Speed Strobe Function
- High Velocity Fan (No Duty Cycle)
- Optional Mini/C or Wireless/C Remote for Blackout (Not Included)

- To reduce the risk of electrical shock or fire, do not expose this unit rain or moisture
- Do not spill water or other liquids into or on to your unit.
- Be sure that the local power outlet match that of the required voltage for your unit.
- Do not attempt to operate this unit if the power cord has been frayed or broken.
- Do not attempt to remove or break off the ground prong from the electrical cord. This prong is used to reduce the risk of electrical shock and fire in case of an internal short.
- Disconnect from main power before making any type of connection.
- Do not remove the cover under any conditions. There are no user serviceable parts inside.
- Never operate this unit when it's cover is removed.
- Never plug this unit in to a dimmer pack
- Always be sure to mount this unit in an area that will allow proper ventilation. Allow about 6" (15cm) between this device and a wall.
- Do not attempt to operate this unit, if it becomes damaged.
- This unit is intended for indoor use only, use of this product outdoors voids all warranties.
- During long periods of non-use, disconnect the unit's main power.
- Always mount this unit in safe and stable matter.
- Power-supply cords should be routed so that they are not likely to be walked on or pinched by items placed upon or against them, paying particular attention to cords at plugs, convenience receptacles, and the point where they exit from the appliance.
- Cleaning -The fixture should be cleaned only as recommended by the manufacturer. See page 16 for cleaning details.
- Heat -The appliance should be situated away from heat sources such as radiators, heat registers, stoves, or other appliances (including amplifiers) that produce heat.
- The fixture should be serviced by qualified service personnel when:
  - A. The power-supply cord or the plug has been damaged.
  - B. Objects have fallen, or liquid has been spilled into the appliance.
  - C. The appliance has been exposed to rain or water.
  - D. The appliance does not appear to operate normally or exhibits a marked change in performance.

## REAR

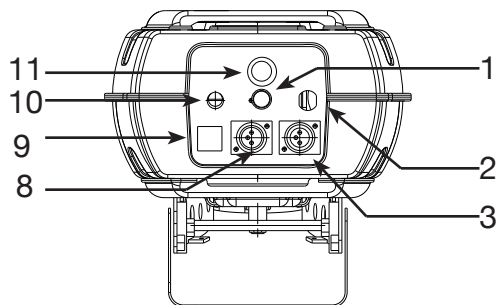

## FRONT

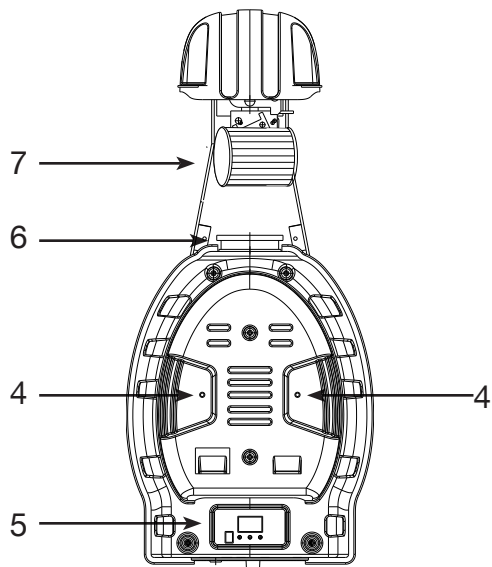

**1. Audio Sensitivity Knob** - This adjusts the audio sensitivity of the INTERNAL MICROPHONE (11). Turning the sensitivity knob in the clockwise direction will increase the sensitivity to sound. Turning the knob in the counter clockwise direction will decrease the fixture's sensitivity to sound.

**2. Blackout Controller Jack** - This jack is for use with the optional Mini/C or Wireless/C controller only. Do not attempt to connect an audio signal to this jack, this will damage the PC board and void your manufactures warranty!

**3. XLR Input Jack** - This jack is used to accept an incoming DMX signal or Master/Slave signal.

**4. Thumb Screws** - These thumb screws hold the lamp socket assembly cover into place.

**5. Digital Display** - This display shows the menu and operating functions that you can choose from.

**6. Lens** - This is a fully focusing high quality lens. Focus the lens by manually turning the lens in a clockwise or counter-clockwise direction.

**7. Barrel Mirror** - This is a highly reflective surface mirror specifically designed to optimize and enhance beam output. Never use glass cleaner that contain ammonia to clean the surface of the mirror (such as Windex).

**8. XLR Output Jack** - This jack is used to transmit the incoming DMX signal to another DMX fixture, or transmit a Master/Slave signal to the next RollerTron 250™ in the chain. For best results in DMX or Master/Slave mode terminate this jack if it is the last unit in the chain. See "Terminator" on page 11.

**9. Breaker** - A 5A built-in safety breaker to reduce the risk of electrical shock or fire and protect the circuitry. In the case of a internal short or power surge.

**10. Power Cord** - Connect only to a matching power outlet. Never use this fixture is the ground prong has been removed or broken off.

**11. Microphone** - This microphone receives external low frequencies to trigger the unit in Sound-Active and Master/Slave mode.

**Operating Modes:**

- **Stand alone mode** - The unit will react to sound or chase through three built-in programs. You can also use the optional Mini/C or Wireless/C Remote Control to blackout and other functions.
- **Master/Slave mode** - You can daisy chain up to 16 units together to get a synchronized light show that will react to sound chasing through several built in programs. You can also use the optional Mini/C or Wireless/C Remote Control to blackout and other functions.
- **DMX control mode** - This function will allow you to control each individual fixtures traits with a standard DMX-512 controller such as the Elation® Show Designer.™
- **Color Changer** - By removing the mirrored head this unit will function as a color change in all the preceding modes. See page 17.

**Universal DMX Control:** This function allows you to use a universal DMX-512 controller such as the Elation® DMX Operator™ or Show Designer™ to control mirror movement, the color wheel, the gobo wheel, and the shutter (strobe). A DMX controller allows you to create unique programs tailored to your individual needs.

1. The RollerTron 250™ uses five DMX channels. Channel 1 controls pan, channel 2 controls tilt, channel 3 controls color channel 4 controls gobo wheel, and channel 5 controls the strobe/shutter function. See pages 13-14 for detailed description of the DMX traits.
2. To control your fixture in DMX mode, follow the set-up procedures on pages 10-12 as well as the set-up specifications that are included with your DMX controller.
3. Use the controller's faders to control the various DMX fixture traits.
4. This will allow you to create your own programs.
5. When using a DMX controller and setting up for DMX operation follow the settings on page 9.
6. For longer cable runs (more than a 100 feet) use a terminator on the last fixture.
7. For help operating in DMX mode consult the manual included with your DMX controller.

**Stand-Alone Operation (Sound Active or Internal Program):**

This mode allows a single unit to run to the beat of the music or chase through one of three programs you can select. You may also choose

to run a big angle program or small angle program, depending on the size of the dance floor. Only use this mode when running a single unit, or when running several units as individuals. See page 9 for details on the different internal programs.

1. The unit will react to the low frequencies of music via the internal microphone. You may also choose to run one of the three internal programs.
2. Adjust the audio sensitivity knob on the bottom of the unit to make the unit more or less sensitive to sound. Turning the sensitivity knob in the clockwise direction will increase the sensitivity, turning the knob in the counter-clockwise direction will decrease the fixture's sensitivity to sound.
3. The optional Mini/C or Wireless/C Controller may be used with this mode to control blackout, slow scan, and strobe functions.

**Master-Slave Operation (Sound Active or Internal Program):**

This function will allow you to link up to 16 units together and operate without a controller. The units will be sound activated. In Master-Slave operation one unit will act as the controlling unit and the others will react to the controlling units programs. Any unit can act as a Master or as a Slave.

1. Using standard XLR microphone cables, daisy chain your units together via the XLR connector on the rear of the units. Remember the Male XLR connector is the input and the Female XLR connector is the output. For longer cable runs we suggest a terminator at the last fixture.
2. Simply daisy chain the units together using XLR cables. Follow the settings on page 9.
3. The optional Mini/C or Wireless/C Controller may be used with in this operation for blackout, slow scan, and strobe function.
4. Use the sensitivity knob on the rear of the master unit to make it more or less sensitive to sound.

*Note: In Stand-Alone and Master-Slave Sound Active operation the units will blackout to conserve lamp life when a sound source is not received.*



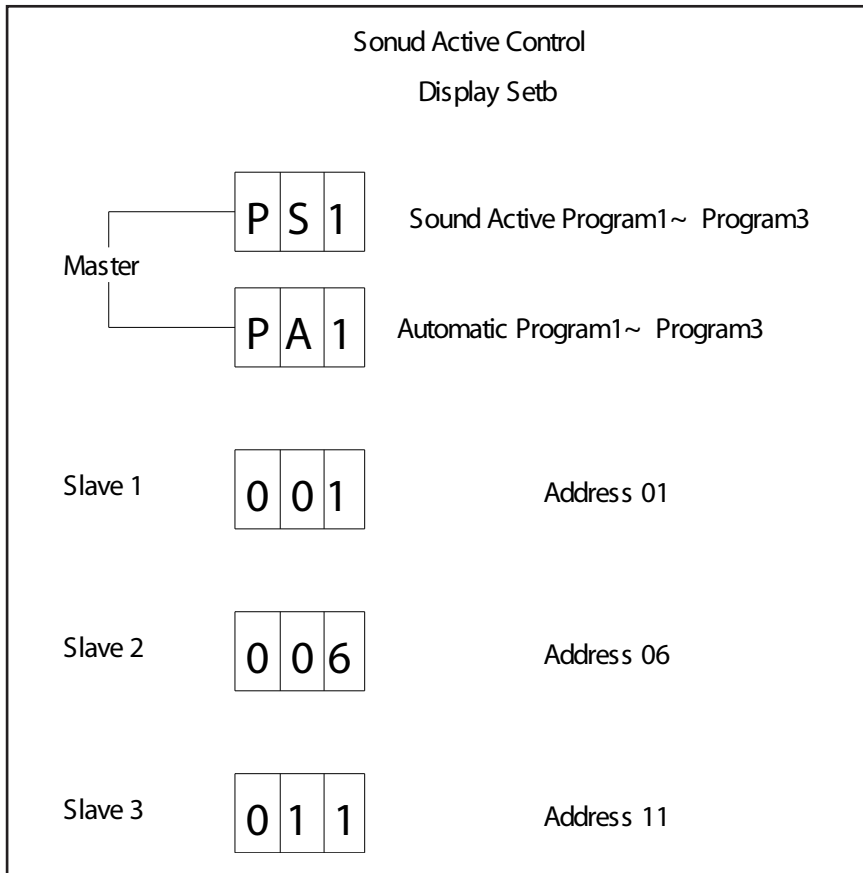

- Program 1 : Big Angle Program Function
- Program 2 : Small Angle Program Function
- Program 3 : Free Angle Program Function

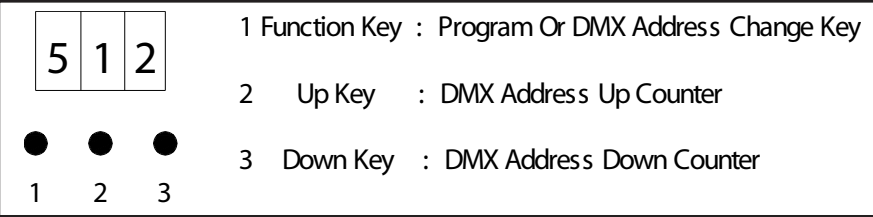

**Power Supply:** Before plugging your unit in, be sure the source voltage in your area matches the required voltage for your American DJ® RollerTron 250.™ The American DJ® RollerTron 250™ is available in a 120v and 220v version. Because line voltage may vary from venue to venue, you should be sure your unit voltages matches the wall outlet voltage before attempting to operate you fixture.

**DMX-512:** DMX is short for Digital Multiplex. This is a universal protocol used as a form of communication between intelligent fixtures and controllers. A DMX controller sends DMX data instructions from the controller to the fixture. DMX data is sent as serial data that travels from fixture to fixture via the DATA “IN” and DATA “OUT” XLR terminals located on all DMX fixtures (most controllers only have a DATA “OUT” terminal).

**DMX Linking:** DMX is a language allowing all makes and models of different manufactures to be linked together and operate from a single controller, as long as all fixtures and the controller are DMX compliant. To ensure proper DMX data transmission, when using several DMX fixtures try to use the shortest cable path possible. The order in which fixtures are connected in a DMX line does not influence the DMX addressing. For example; a fixture assigned a DMX address of 1 may be placed anywhere in a DMX line, at the beginning, at the end, or anywhere in the middle. When a fixture is assigned a DMX address of 1, the DMX controller knows to send DATA assigned to address 1 to that unit, no matter where it is located in the DMX chain.

**Data Cable (DMX Cable) Requirements (For DMX and Master/Slave Operation):** The RollerTron 250™ can be controlled via DMX-512 protocol. The RollerTron 250™ is a five channel DMX unit. The DMX address is set on the bottom panel of the RollerTron 250.™ Your unit and your DMX controller require a standard 3-pin XLR connector for data input and data output (Figure 1). If you are making your own cables, be sure to use standard two conductor shielded cable (This cable may be purchased at almost all pro sound and lighting stores). Your cables should be made with a male and female XLR connector on either end of the cable. Also remember that DMX cable must be daisy chained and can not be split.



Figure 1

**Notice:** Be sure to follow figures two and three when making your own cables. Do not use the ground lug on the XLR connector. Do not connect the cable's shield conductor to the ground lug or allow the shield conductor to come in contact with the XLR's outer casing. Grounding the shield could cause a short circuit and erratic behavior.

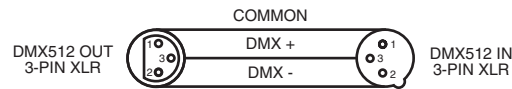
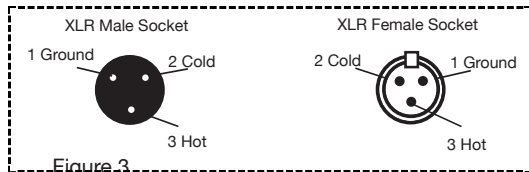

Figure 2



XLR Pin Configuration	
Pin 1 =	Ground
Pin 2 =	Data Compliment (negative)
Pin 3 =	Data True (positive)

**Special Note: Line Termination.** When longer runs of cable are used, you may need to use a terminator on the last unit to avoid erratic behavior. A terminator is a 90-120 ohm 1/4 watt resistor which is connected between pins 2 and 3 of a male XLR connector (DATA + and DATA -). This unit is inserted in the female XLR connector of the last unit in your daisy chain to terminate the line. Using a cable terminator (ADJ part number Z-DMX/T) will decrease the possibilities of erratic behavior.



Termination reduces signal errors and avoids signal transmission problems and interference. It is always advisable to connect a DMX terminal, (Resistance 120 Ohm 1/4 W) between PIN 2 (DMX-) and PIN 3 (DMX +) of the last fixture.

Figure 4

**5-Pin XLR DMX Connectors.** Some manufactures use 5-pin XLR connectors for DATA transmission in place of 3-pin. 5-pin XLR fixtures may be implemented in a 3-pin XLR DMX line. When inserting standard 5-pin XLR connectors in to a 3-pin line a cable adaptor must be used, these adaptors are readily available at most electric stores. The chart below details a proper cable conversion.

3-Pin XLR to 5-Pin XLR Conversion		
Conductor	3-Pin XLR Female (Out)	5-Pin XLR Male (In)
Ground/Shield	Pin 1	Pin 1
Data Compliment (- signal)	Pin 2	Pin 2
Data True (+ signal)	Pin 3	Pin 3
Not Used		Pin 4 - Do Not Use
Not Used		Pin 5 - Do Not Use

RollerTron 250™		DMX Traits
Channel	Value	Function
1	0 - 255	PAN
2	0 - 255	TILT
3 ↓	<u>1 - 255</u>	<u>COLOR</u>
	1 - 20	WHITE
	21 - 41	RED
	42 - 62	BLUE
	63 - 83	GREEN
	84 - 104	YELLOW
	105 - 125	ORANGE
	126 - 146	PINK
	147 - 167	4 COLOR
	168 - 254	RAINBOW EFFECT
	255	SLOW → FAST SOUND ACTIVE
4 ↓		<u>GOBO</u>
	0 - 7	<u>SPOT</u>
	8 - 15	GOBO 1
	16 - 23	GOBO 2
	24 - 31	GOBO 3
	32 - 39	GOBO 4
	40 - 47	GOBO 5
	48 - 55	GOBO 6
	56 - 63	GOBO 7
	64 - 71	GOBO 8
	72 - 79	GOBO 9
	80 - 87	GOBO 10
	88 - 95	BLACK OUT
	96 - 103	GOBO SPOT SHAKE
	104 - 111	GOBO 1 SHAKE
	112 - 119	GOBO 2 SHAKE

RollerTron 250™		DMX Traits
Channel	Value	Function
4 ↓		<u>GOBO</u>
	120 - 127	GOBO 3 SHAKE
	128 - 135	GOBO 4 SHAKE
	136 - 143	GOBO 5 SHAKE
	144 - 151	GOBO 6 SHAKE
	152 - 159	GOBO 7 SHAKE
	160 - 167	GOBO 8 SHAKE
	168 - 175	GOBO 9 SHAKE
	176 - 183	GOBO 10 SHAKE
	184 - 191	BLACKOUT
192 - 254	GOBO ROTATION	
	255	SLOW → FAST SOUND ACTIVE
5 ↓		<u>SHUTTER</u>
	0	LAMP OFF
	1 - 6	BLACKOUT
	7 - 251	STROBING
	252 - 255	SLOW 1 FPS* → FAST 10 FPS* SHUTTER OPEN

\*FPS = FLASHES PER SECOND

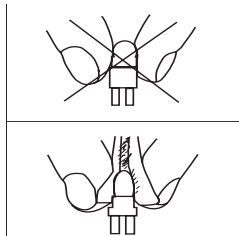

This fixture is fitted with halogen lamps which are highly susceptible to damage if improperly handled. Never touch the lamps with your bare fingers as the oil from your hands will shorten lamp life. Also, never move the fixture until the lamps have had ample time to cool. Remember, lamps are not covered under warranty conditions.

**Caution:** Always replace with the exact same type lamp, unless otherwise specified by an authorized American DJ® service technician. Replacing with anything other than the specified part can damage your unit and will void your manufacturer's warranty.

**Warning:** If you continue to blow lamps or the breaker, STOP using the unit. Contact customer support for further instructions, you may have to return the unit for servicing. Continuing to use the unit may cause serious damage.

**Lamp Replacement:** Caution! Never attempt to change the lamp while the fixture is plugged in. Always disconnect the main power and allow the unit ample time to cool before attempting to replace the lamp. Lamp replacement has been made simple by incorporating the use of a flip-up front cover that is retained by thumb screws.

1. Be sure to follow the proper handling procedures that deal with halogen lamps.
2. Remove the thumb screws on the front of the unit that holds the lamp socket assembly cover in place.
3. After removing the thumb screw, remove cover from the front of the unit to expose the lamp socket assembly.
4. Carefully remove the old lamp and discard it in the trash.
5. Replace the lamp with an exact match and reassemble in reverse order.

This unit is equipped with a built-in safety breaker. This breaker is designed to close the power circuit in the event of an internal short or power surge. This will reduce the risk of electrical shock or fire and protect the circuitry. To reset the breaker, push the breaker button in until you hear it “pop” back in to place. If the breaker continues to pop, stop using the unit and contact our customer support team, the unit may need to be returned for service.

**Fixture Cleaning:** Due to fog residue, smoke, and dust cleaning the internal and external optical lenses and mirror should be carried out periodically to optimize light output. Cleaning frequency depends on the environment in which the fixture operates (i.e. smoke, fog residue, dust, dew). In heavy club use we recommend cleaning on a monthly basis. Periodic cleaning will ensure longevity, and crisp output.

1. Use normal glass cleaner and a soft cloth to wipe down the outside casing.
2. Use a brush to wipe down the cooling vents and fan grill.
3. Clean the external optics and mirror with glass cleaner and a soft cloth every 20 days.
4. Clean the internal optics with glass cleaner and a soft cloth every 30-60 days.
5. Always be sure to dry all parts completely before plugging the unit back in.

**Trouble Shooting:** Listed below are a few common problems that you may encounter, with solutions.

**No light output from the unit;**

1. Be sure you have connected your unit into a standard 120v wall outlet.
2. Be sure the external breaker has not blown. The breaker is located on the bottom panel of the unit.
3. Remove the lamp cover and be sure the lamp is seated in its socket properly. Occasionally lamps become loose during shipping be sure the lamp is pushed in to its socket all the way.

**Unit does not respond to sound;**

1. Low frequencies (bass) should cause the unit to react to sound. Tapping on the microphone, quiet or high pitched sounds may not activate the unit.
2. Be sure the *SENSITIVITY KNOB (1)* is not set to the minimum position (full counter-clockwise).



The RollerTron 250™ is designed with a removable mirror head. When the head is removed the unit can be used as a color changer with gobo patterns. The unit will function normally in all operating modes with the exception of mirror movements. To remove the head; 1) Disconnect the mirror interface cable, located on the back underneath the mirror shield. 2) Unscrew the two phillips screws (one on each side) located in front of the bracket. These secure the head assembly to the body. 3) Remove the screws and gently pull it away from the body.

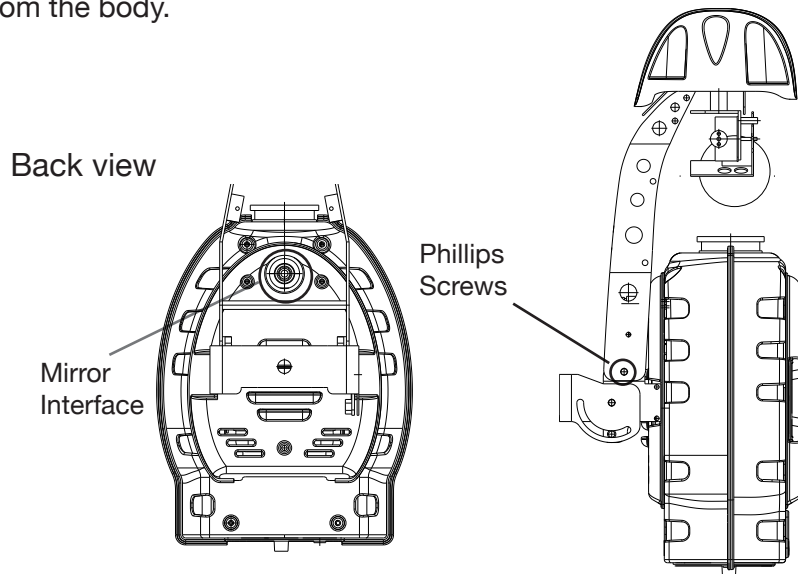

The RollerTron 250™ comes provided with a special mirror shield, that protects the mirror from getting damaged or broken while transporting the unit. To attach the shield to protect the mirror, reassemble it as your first go it. To attach it to the back of unit for storage: 1) Take the thumb screws and attach the shield to the neck assembly that hold the mirror head. 2) You will notice two little brackets extending out from the neck. Attach the shield (the screw holes located near the top of the shield will line up with the bracket holes) screw the thumb screws into these small brackets.

## 1-YEAR LIMITED WARRANTY

A. American DJ® hereby warrants, to the original purchaser, American DJ® products to be free of manufacturing defects in material and workmanship for a period of 1 Year (365 days) from the date of purchase. This warranty shall be valid only if the product is purchased within the United States of America, including possessions and territories. It is the owner's responsibility to establish the date and place of purchase by acceptable evidence, at the time service is sought.

B. For warranty service, send the product only to the American DJ® factory. All shipping charges must be pre-paid. If the requested repairs or service (including parts replacement) are within the terms of this warranty, American DJ® will pay return shipping charges only to a designated point within the United States. If the entire instrument is sent, it must be shipped in its original package. No accessories should be shipped with the product. If any accessories are shipped with the product, American DJ® shall have no liability whatsoever for loss of or damage to any such accessories, nor for the safe return thereof.

C. This warranty is void if the serial number has been altered or removed; if the product is modified in any manner which American DJ® concludes, after inspection, affects the reliability of the product; if the product has been repaired or serviced by anyone other than the American DJ® factory unless prior written authorization was issued to purchaser by American DJ®; if the product is damaged because not properly maintained as set forth in the instruction manual.

D. This is not a service contract, and this warranty does not include maintenance, cleaning or periodic check-up. During the period specified above, American DJ® will replace defective parts at its expense, and will absorb all expenses for warranty service and repair labor by reason of defects in material or workmanship. The sole responsibility of American DJ® under this warranty shall be limited to the repair of the product, or replacement thereof, including parts, at the sole discretion of American DJ®. All products covered by this warranty were manufactured after January 1, 1990, and bear identifying marks to that effect.

E. American DJ® reserves the right to make changes in design and/or improvements upon its products without any obligation to include these changes in any products theretofore manufactured.

F. No warranty, whether expressed or implied, is given or made with respect to any accessory supplied with products described above. Except to the extent prohibited by applicable law, all implied warranties made by American DJ® in connection with this product, including warranties of merchantability or fitness, are limited in duration to the warranty period set forth above. And no warranties, whether expressed or implied, including warranties of merchantability or fitness, shall apply to this product after said period has expired. The consumer's and or Dealer's sole remedy shall be such repair or replacement as is expressly provided above; and under no circumstances shall American DJ® be liable for any loss or damage, direct or consequential, arising out of the use of, or inability to use, this product.

G. This warranty is the only written warranty applicable to American DJ® Products and supersedes all prior warranties and written descriptions of warranty terms and conditions heretofore published.

H. Lamps are not covered under this or any other warranty, either written or implied.

<b>Model:</b>	<b>RollerTron 250™</b>
<b>Voltage*:</b>	120v/60Hz or 220v/50Hz
<b>Lamp:</b>	ZB-ELC10, 24v/250w
<b>Dimensions:</b>	21"(L) x 10"(W) x 8"(H) 533mm x 254mm x 203mm
<b>Colors:</b>	6 Plus White
<b>Gobos:</b>	10 Plus Spot
<b>Weight:</b>	12 Lbs./5.4 Kgs.
<b>Breaker:</b>	5A(120v) / 3A (230v)
<b>Cooling:</b>	High Velocity Fan
<b>Duty Cycle:</b>	None
<b>DMX:</b>	5 Channels
<b>Sound Active:</b>	Yes
<b>Working Position:</b>	Any Safe, Secure Position
<b>Warranty:</b>	1 Year (365 days)

\*Voltage is preset at the factory and is not user selectable

**Please Note:** Specifications and improvements in the design of this unit and this manual are subject to change without any prior written notice.

American DJ®  
 American DJ World Headquarters:  
 4295 Charter Street Los Angeles, CA 90058 USA  
 Tel: 323-582-2650 / Fax: 323-582-2610  
 Web: [www.americandj.com](http://www.americandj.com) / E-mail: [info@americandj.com](mailto:info@americandj.com)