

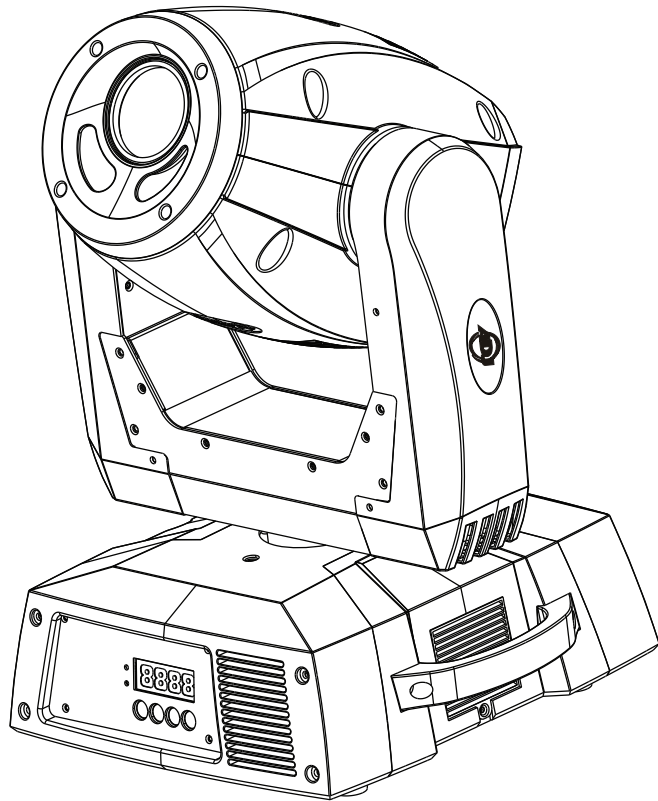

VIZI SPOT 5R



User Instructions

American DJ®

Vizi Spot 5R

Table of Contents

| | |
|--|----|
| Unpacking..... | 3 |
| Introduction..... | 3 |
| Customer Support..... | 3 |
| Safety Precautions..... | 4 |
| Features..... | 5 |
| RDMX..... | 5 |
| Handling Precautions..... | 6 |
| Registration..... | 6 |
| Important Discharge Lamp Warnings..... | 7 |
| Mounting..... | 8 |
| Controls and Functions..... | 10 |
| DMX Set-Up..... | 13 |
| System Menu..... | 16 |
| Editing Program..... | 31 |
| Error Codes..... | 40 |
| Operating Modes..... | 42 |
| DMX Traits..... | 44 |
| Gobo Replacement..... | 52 |
| Lamp & Fuse Replacement..... | 53 |
| Cleaning..... | 54 |
| Trouble Shooting..... | 54 |
| Warranty..... | 55 |
| Specifications..... | 56 |

Please see page 7 for important lamp instructions!



Unpacking: Thank you for purchasing the Vizi Spot 5R by American DJ®. Every Vizi Spot 5R has been thoroughly tested and has been shipped in perfect operating condition. Carefully check the shipping carton for damage that may have occurred during shipping. If the carton appears to be damaged, carefully inspect your fixture for any damage and be sure all equipment necessary to operate the unit has arrived intact. In the event damage has been found or parts are missing, please contact our toll free customer support number for further instructions. Please do not return this unit to your dealer without contacting customer support first.

Introduction: The Vizi Spot 5R is a DMX intelligent, moving head fixture. The Vizi Spot 5R can be a 11 channel or 13 channel DMX unit. The fixture can operate in three different operating modes; show mode, sound-active, or under DMX control. The Vizi Spot 5R can be used as a stand alone unit or in a master/slave configuration. *For best results use fog or special effects smoke to enhance the beams projections.*

During the initial start-up or use of this product a light smoke or smell may arise from the unit. This is a normal process and is cause by the heat associated with the lamp.

Customer Support: American DJ® provides a toll free customer support line, to provide help and to answer any question should you encounter problems during your set up or initial operation. You may also visit us on the web at www.americandj.com for any comments or suggestions. Service Hours are Monday through Friday 8:00 a.m. to 4:30 p.m. Pacific Standard Time.

Voice: (800) 322-6337

Fax: (323) 582-2610

E-mail: support@americandj.com

To purchase parts online visit <http://parts.americandj.com>

Warning! To prevent or reduce the risk of electrical shock or fire, do not expose this unit to rain or moisture.

Warning! *This may cause severe eye damage. Avoid looking directly into the light source at all times!*

For Your Own Personal Safety, Please Read and Understand This Manual Completely Before You Attempt To Install Or Operate This Unit!

- To reduce the risk of electrical shock or fire, do not expose this unit rain or moisture
- Do not spill water or other liquids into or on to your unit.
- Be sure that the local power outlet match that of the required voltage for your unit.
- Do not attempt to operate this unit if the power cord has been frayed or broken.
- Do not attempt to remove or break off the ground prong from the electrical cord. This prong is used to reduce the risk of electrical shock and fire in case of an internal short.
- Disconnect from main power before making any type of connection.
- Do not remove the cover under any conditions. There are no user serviceable parts inside.
- Never operate this unit when it's cover is removed.
- Always be sure to mount this unit in an area that will allow proper ventilation. Allow about 6" (15cm) between this device and a wall.
- Do not attempt to operate this unit, if it becomes damaged.
- This unit is intended for indoor use only, use of this product outdoors voids all warranties.
- Always mount this unit in safe and stable matter.
- Power-supply cords should be routed so that they are not likely to be walked on or pinched by items placed upon or against them, paying particular attention to cords at plugs, convenience receptacles, and the point where they exit from the appliance.
- Cleaning -The fixture should be cleaned only as recommended by the manufacturer. See page 54 for cleaning details.
- Heat -This fixture should be situated away from heat sources such as radiators, heat registers, stoves, or other appliances (including amplifiers) that produce heat.
- The fixture should be serviced by qualified service personnel when:
 - A. Objects have fallen, or liquid has been spilled into the appliance.
 - B. The appliance has been exposed to rain or water.
 - C. The appliance does not appear to operate normally or exhibits a marked change in performance.

Vizi Spot 5R

Features

- Micro-Stepping Motors for Smooth Color and Gobo Transitions
- 2 Modes of DMX-512 Protocol Compatible (11 DMX Channel Mode or 13 DMX Channel Mode)
- Independent Gobo and Color Wheels
- 8 Rotating Gobos + Spot All Replaceable (4 x Metal 4 x Glass)
- 8 Colors, Plus White - With Rainbow
- RDMX - Lets you set the DMX address from any DMX Controller
- 3 Operating Modes - Master/Slave; Stand Alone; Sound Active
- Internal Microphone
- Philips® Platinum 5R Discharge
- Edit and Save Scenes into the Memory
- Manual Focus Lens
- 360°/540° Pan Movement
- 270° Tilt Movement
- Digital Display for Address and Function Setting

Vizi Spot 5R

RDMX Addressing

Regarding RDMX :

1. The units will be shipped preset in 16 channel increments from the factory
2. While using RDMX, if all units are set to the same DMX address, all units will change to the new DMX address you selected.

EXAMPLE: You have four units, and all the units are set to the DMX address of “1”, and you change one unit to DMX address “17”, this will cause all the units to change to DMX address “17”.

All four units must be on 4 different starting addresses to individually set the DMX addresses for each unit.

For more on this feature see pages 29-30.

Vizi Spot 5R

General Instructions

To optimize the performance of this product, please read these operating instructions carefully to familiarize yourself with the basic operations of this unit. These instructions contain important safety information regarding the use and maintenance of this unit. Please keep this manual with the unit, for future reference.

Vizi Spot 5R

Handling Precautions

Caution! There are no user serviceable parts inside this unit. Do not attempt any repairs yourself, doing so will void your manufacturer's warranty. In the unlikely event your unit may require service please contact American DJ®.

During operation the housing may become extremely hot. Avoid touching the unit with bare hands while in use.

American DJ® will not accept any liability for any resulting damages caused by the non-observance of this manual or any unauthorized modification to this unit.

Vizi Spot 5R

Product Registration

The Vizi Spot 5R carries a one year limited warranty. Please fill out the enclosed warranty card to validate your purchase. All returned service items whether under warranty or not, must be freight pre-paid and accompany a return authorization (R.A.) number. The R.A. number must be clearly written on the outside of the return package. A brief description of the problem as well as the R.A. number must also be written down on a piece of paper and included in the shipping carton. If the unit is under warranty, you must provide a copy of your proof of purchase invoice. You may obtain a R.A. number by contacting our customer support team on our toll free customer support number. All packages returned to the service department not displaying a R.A. number on the outside of the package will be returned to the shipper at the shippers cost.

Vizi Spot 5R

Important Discharge Lamp Warning

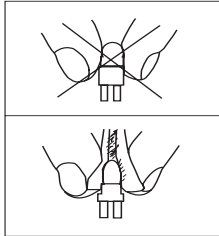

This fixture is fitted with a discharge lamp which is highly susceptible to damage if improperly handled. Never touch the lamp with your bare fingers as the oil from your hands will shorten lamp life. Also, never move the fixture until the lamps have had ample time to cool. Remember, lamps are not covered under warranty conditions.

This unit emits intense UV radiation which is harmful to the eyes and skin. The intense luminance of the lamp can cause severe damage to the retina. Never operate this unit without its covers, these covers have been specially designed to shield against UV radiation.

Epileptic Warning: Those suffering from epilepsy should avoid looking directly into the lamp at all times.

Avoid switching the fixture on and off repeatedly in short intervals as this will reduce lamp life and intensity.

To achieve the intensity associated with discharge lamps, these lamps use gas sealed in a high pressure environment to emit a brilliant output. Due to the high pressure involved with the construction of the lamp, the lamp may explode during prolonged extensive use. This risk is increased with age, added care is encouraged when dealing with older lamps. Extreme caution should be used when operating this or any fixture fitted with a gas discharge lamp. Never open this unit while in use.

VERY IMPORTANT: This is for your safety and the life length of the unit. The Philips® Platinum 5R Discharge lamp has lifetime of 2000 hours.

When the lamp reaches the 2000 hour mark, the display will begin to flash "LAMP". When the lamp reaches the 2000 hour mark and power is applied, the lamp will strobe for 5 mins. and the display will begin to flash "LAMP". You may continue to run the fixture and use the lamp for another 300 hours. Once 2300 hours is reached the LCD display will begin to flash "LAMP", the DMX signal will shut off, and the fixture will go into hibernation status and will not move.

Any fixtures daisy chained to the unit will stay powered on, as long as their respective lamp has not reached 2300 hours. The unit will start running again once you have replaced the lamp and cleared the LAMP RUNNING TIME (see top of page 25 "CLMP"). Clear the LAMP RUNNING TIME after you have replaced the lamp. See page 53 for lamp replacement instructions.

Warning: DO NOT use this lamp more than 2300 hours. Using the lamp any longer than the set life could seriously damage your unit.

Vizi Spot 5R

Mounting

When installing the unit, the trussing or area of installation must be able to hold 10 times the weight without any deformation. When installing the unit must be secured with a secondary safety attachment, e.g. and appropriate safety cable. Never stand directly below the unit when mounting, removing, or servicing the unit.

Overhead mounting requires extensive experience, including calculating working load limits, installation material being used, and periodic safety inspection of all installation material and unit. If you lack these qualifications, do not attempt the installation yourself.

These installation should be checked by a skilled person once a year.

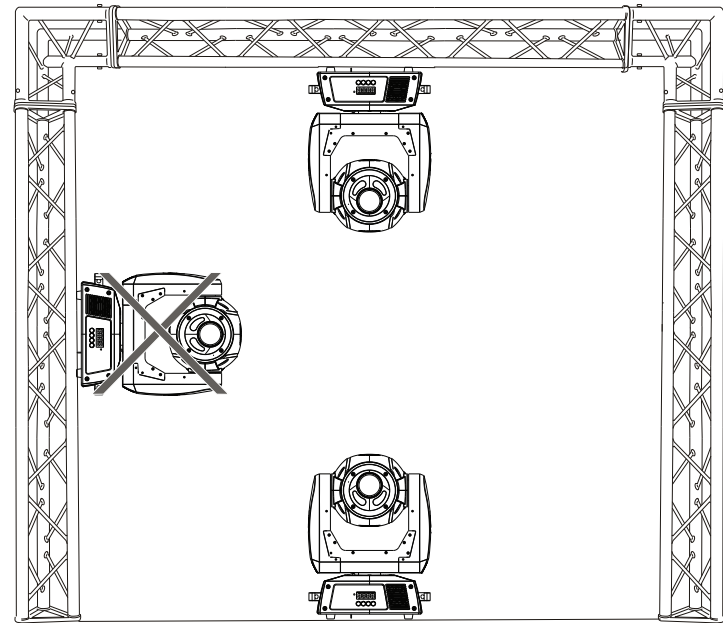

The Vizi Spot 5R is fully operational in two different mounting positions, hanging upside-down from a ceiling or set on a flat level surface. To avoid internal damage to the unit, never mount the unit on its side as illustrated above. Be sure this fixture is kept at least 0.5m away from any flammable materials (decoration etc.). Always use and install the supplied safety cable as a safety measure to prevent accidental damage and/or injury in the event the clamp fails (see next page). Never use the carrying handles for secondary attachment.

NOTICE: The suitable environmental temperature for this lighting fixture is between -25° C to 45° C. Do not place this lighting fixture in an environment where the temperatures are under or above the temperatures stated above. This will allow the fixture to run at its best and help prolong the fixture life.

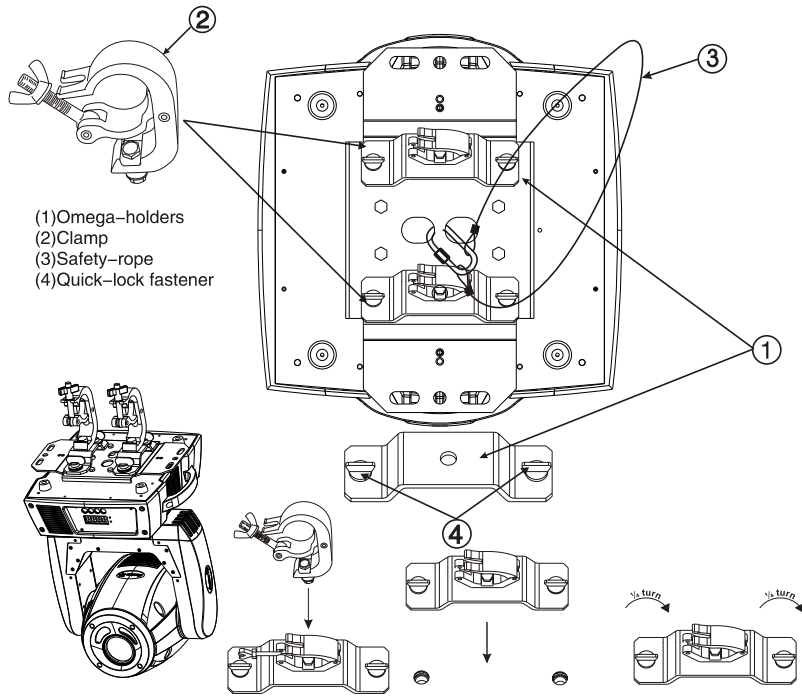

Screw one clamp each via a M12 screw and nut onto the Omega holders. Insert the quick-lock fasteners of the first Omega holder into the respective holes on the bottom of the Vizi Spot 5R. Tighten the quick-lock fasteners fully clockwise. Install the second Omega holder. Pull the safety-cable through the holes on the bottom of the base and over the trussing system or a safe fixation spot. Insert the end in the carabine and tighten the safety screw.

FRONT

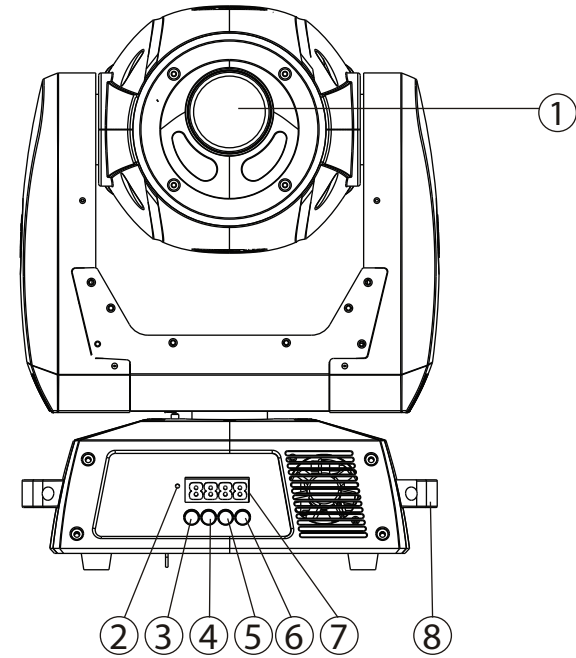

REAR

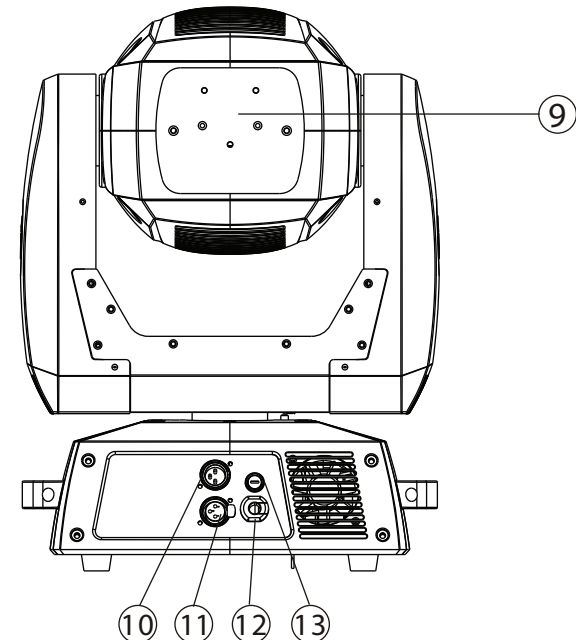

1. Lens Assembly - This high quality lens can be focused in DMX mode. Please see pages 44-51 for DMX values and functions.

2. Microphone - This microphone receives external low frequencies to trigger the unit in Sound-Active mode. This microphone is designed to receive low frequency sounds only, tapping on the microphone and high pitch sounds may not trigger the unit.

3. Mode/Esc Button - This button is used to enter the main menu and submenus. It is also used to exit.

4. Up Button - This button is used to scroll forwards when navigating through the system menu.

5. Down Button - This button is used to scroll backwards when navigating through the system menu.

6. Enter Button - This button is used to select and confirm a function in the system menu.

7. Digital Display - This display shows the menu and operating functions that you can choose from.

8. Carrying Handles - The includes built-in carrying handles. Be sure to always handle the unit by the built-in handles. Never lift or carrying the unit by head or yoke. Pulling on or transporting the unit by the moving head may severely damage the unit and will void the unit warranty.

9. Lamp Assembly and Access Plate - This plate accesses the lamp socket assembly. The unit includes a spring mounted discharge lamp. Be sure to only replace with same type lamp. After replacing a lamp be sure the lamp is centered in the reflector. See pages 53-54 for details on installing and optimizing replacement lamps. Never operate this unit with the lamp exposed, this lamp emits strong UV radiation. Please see page 7 for important information about the Philips® Platinum 5R discharge lamp.

10. XLR DMX Input Jack - This jack is used to receive an incoming DMX signal or Master/Slave signal.

11. XLR Output Jack - This jack is used to transmit the incoming DMX signal to another DMX fixture, or transmit a Master/Slave signal to the next Vizi Spot 5R in the chain. For best results in DMX or Master/

Slave mode terminate this jack if it is the last unit in the chain. See “Line Termination” on page 14.

12. Power Cord Inlet - This cord is designed to match the electrical requirements of the unit. Voltage may vary from venue to venue, when connecting this unit to a power supply be sure to connect to a matching power outlet. Never use this fixture if the ground prong has been removed or broken off. The ground prong is designed to reduce the risk of fire or electrical shock in the event the unit suffers from an internal short.

13. Fuse Holder - This housing stores a 5 amp (3 amp 220v) protective fuse. Never defeat the fuse, the fuse is designed to protect the electronics in the event of severe power fluctuations. Always be sure to replace the fuse with an exact match as the one being replaced, unless otherwise told to do so by an authorized American DJ® service technician.

Power Supply: The American DJ® Vizi Spot 5R contains a electronic ballast, which will auto sense the voltage when it is plugged into the power source. With the electronic ballast you do not need to worry about wall voltage, this unit can be plugged in anywhere.

DMX-512: DMX is short for Digital Multiplex. This is a universal protocol used by most lighting and controller manufactures as a form of communication between intelligent fixtures and controllers. A DMX controller sends DMX data instructions from the controller to the fixture. DMX data is sent as serial data that travels from fixture to fixture via the DATA “IN” and DATA “OUT” XLR terminals located on all DMX fixtures (most controllers only have a DATA “OUT” terminal).

DMX Linking: DMX is a language allowing all makes and models of different manufactures to be linked together and operate from a single controller, as long as all fixtures and the controller are DMX compliant. To ensure proper DMX data transmission, when using several DMX fixtures try to use the shortest cable path possible. The order in which fixtures are connected in a DMX line does not influence the DMX addressing. For example; a fixture assigned a DMX address of 1 may be placed anywhere in a DMX line, at the beginning, at the end, or anywhere in the middle. Therefore, the first fixture controlled by the controller could be the last fixture in the chain. When a fixture is assigned a DMX address of 1, the DMX controller knows to send DATA assigned to address 1 to that unit, no matter where it is located in the DMX chain.

Data Cable (DMX Cable) Requirements (For DMX and Master/Slave Operation): The Vizi Spot 5R can be controlled via DMX-512 protocol. The Vizi Spot 5R can be either a 11 or 13 channel DMX unit. The DMX address is set electronically using the controls on the side panel of the unit. Your unit and your DMX controller require a approved DMX-512 110 Ohm Data cable for data input and data output (Figure 1). We recommend Accu-Cable DMX cables. If you are making your own cables, be sure to use standard 110-120 Ohm shielded cable (This cable may be purchased at almost all professional sound and lighting stores). Your cables should be made with a male and female XLR connector on either end of the cable. Also remember that



Figure 1

DMX cable must be daisy chained and cannot be split.

Notice: Be sure to follow figures two and three when making your own cables. Do not use the ground lug on the XLR connector. Do not connect the cable’s shield conductor to the ground lug or allow the shield conductor to come in contact with the XLR’s outer casing. Grounding the shield could cause a short circuit and erratic behavior.

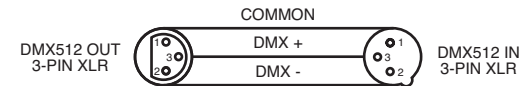

Figure 2

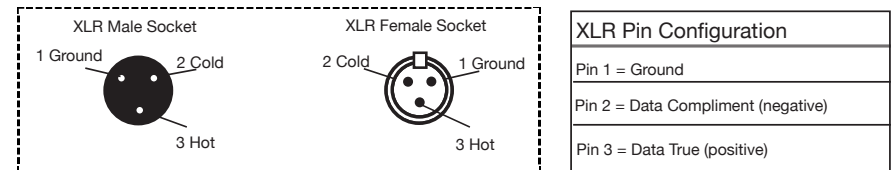

Figure 3

Special Note: Line Termination. When longer runs of cable are used, you may need to use a terminator on the last unit to avoid erratic behavior. A terminator is a 110-120 ohm 1/4 watt resistor which is connected between pins 2 and 3 of a male XLR connector (DATA + and DATA -). This unit is inserted in the female XLR connector of the last unit in your daisy chain to terminate the line. Using a cable terminator (ADJ part number Z-DMX/T) will decrease the possibilities of erratic behavior.



Termination reduces signal errors and avoids signal transmission problems and interference. It is always advisable to connect a DMX terminal. (Resistance 120 Ohm 1/4 W) between PIN 2 (DMX-) and PIN 3 (DMX +) of the last fixture.

Figure 4

5-Pin XLR DMX Connectors. Some manufactures use 5-pin DMX-512 data cables for DATA transmission in place of 3-pin. 5-pin DMX fixtures may be implemented in a 3-pin DMX line. When inserting standard 5-pin data cables in to a 3-pin line a cable adaptor must be used, these adaptors are readily available at most electric stores. The chart below details a proper cable conversion.

| 3-Pin XLR to 5-Pin XLR Conversion | | |
|-----------------------------------|------------------------|---------------------|
| Conductor | 3-Pin XLR Female (Out) | 5-Pin XLR Male (In) |
| Ground/Shield | Pin 1 | Pin 1 |
| Data Compliment (- signal) | Pin 2 | Pin 2 |
| Data True (+ signal) | Pin 3 | Pin 3 |
| Not Used | | Pin 4 - Do Not Use |
| Not Used | | Pin 5 - Do Not Use |

| | | | | | |
|------|----------------|-----------------------------|--------------------------|---|--|
| 0 | MODE | ADDR | VALU | A001~A511 (AXXX) | DMX address setting |
| | | | SLAV | ON/OFF (SLAV) | Slave setting |
| | | | EBOC | ON/OFF | Change DMX address via external controller |
| | | RUN | AUTO | ALON (AU-A) | Automatic Run in Stand Alone |
| | | | | MAST (AU-M) | Automatic Run as Master |
| | | | SOUN | ALON (SO-A) | Sound-controlled Run in Stand Alone |
| | MAST (SO-M) | | | Sound-controlled Run as Master | |
| | DISP | VALU | D-XX D-00 (DXXX) | Display the DMX 512 value of each channel | |
| | | RDIS | ON/OFF | Reverse display | |
| | | CLDI | ON/OFF | Shut off LED display | |
| | | LOCK | ON/OFF | Key Lock | |
| | 1 | LAMP | OPEN | ON/OFF | Lamp on/off |
| LAAU | | | ON/OFF | Lamp automated on with power | |
| ONLI | | | ON/OFF | Lamp on/off via controller | |
| DELA | | | D-XX D-05 | Delay lamp on | |
| 2 | SET | RPAN | ON/OFF | Pan Reverse | |
| | | RTIL | ON/OFF | Tilt Reverse | |
| | | 16BI | ON/OFF | Switch 16 bit/8 bit | |
| | | DEGR | 360/540 | Pan degree select | |
| | | MIC | M-XX M-70 | Mic sensitivity | |
| | | AUTO | Clos/Hold/Auto/Audi | No DMX Status | |
| | | FANS | AUTO/HIGH/LOW | Fan's mode select | |
| | | REST | | Reset | |
| | | LODA | ON/OFF | Restore factory settings | |
| | | HIBE | OFF/1-99M 15M | Stand by mode | |
| | | VER | V-1.0~V-9.9 | Software version | |
| | | 3 | ADJU | LADJ | ON/OFF |
| TEST | T-01~T-XX | | | Test function of each channel | |
| WHEL | CODE CH01~CHXX | | | Fixture code *code is "C050" Motor Fix | |
| 4 | TIME | MATI | 0000~9999(hours) | Fixture running time | |
| | | LATI | 0000~9999(hours) | Lamp running time | |
| | | CLMT | ON/OFF (Password is 838) | Clear fixture time | |
| | | CLLT | ON/OFF | Clear lamp time | |
| 5 | EDIT | SEPR | AUTO IP01~IP08 | Select program to be edit | |
| | | STEP | S-01 ~S-48 | Steps of Program Run | |
| | | REC. | RE.XX | Auto Save Scene | |
| | | SC01 ~ SC48 | C-01~C-XX | XXX(000~255) | Edit the channels of each scene |
| | | | TIME | XXXX(000.2s~199.8s) | Time for each scene |
| CNIN | ON/OFF | Edit program via controller | | | |

ADDRESS MENU -

ADDR - This is where you set the DMX address of the unit.

TEST MENU -

T-01 - T-XX - Tests the functions of each channel.

Note: Some channels cannot be tested.

PLAY MENU -

AUTO - This is a precaution mode in case the DMX signal is lost. There are four settings to choose from:

- “Clos” - The fixture will close the lens shutters.
- “Hold” - This is the default setting, which in case the signal is lost the fixture will “hold” at the last setting.
- “Auto” - The fixture will go into Auto mode and run a pre-programmed show.
- “Audi” - The fixture will go into Sound Active mode.

LAMP MENU -

ON/OFF - Manually switches the lamp “On” or “Off”.

RESE (RESET) MENU -

ALL - Resets all motors.

SCAN - Resets the pan/tilt motors.

COLR (Color) - Resets the color wheel motor.

GOBO - Resets the gobo wheel motor.

SHTR (Shutter) - Resets the shutter and dimmer motors.

OTHR - Resets all other motors.

TIME MENU -

LIFE - Displays the total fixture running time.

LAMP - Displays the lamp running time.

CLMP - Clears the lamp running time.

RPAN MENU -

ON/OFF - Reverses the pan.

RTLT MENU -

ON/OFF - Reverses the tilt.

FINE MENU -

ON/OFF - Switch between 8bit (coarse) and 16bit (fine) pan & tilt movement. This also switches the DMX channel mode between 11 channel (8 bit) and 13 channel (16 bit) DMX mode.

DEGR MENU -

540/360 - Switch the degree of the Pan between 360 and 540.

MIC MENU -

M-01-M-70 - With this function you can make the internal mic more or less sensitive to sound.

DISPLAY MENU -

VALU (DMX-512 Value) - Display the DMX-512 value of each channel.

DOFF - Turns digital display off after 2 minutes.

FLIP - “Flips” the digital display 180°.

LOCK - When activated the buttons will lock automatically after 15 seconds.

SPEC MENU -

LAMP - On/Off Automatically switches on lamp when power is applied.

RDMA - On/Off With this function you are able to change the DMX address via external controller. See pages 29-30.

ADJ (Lamp Adjustment) - With this function you can adjust the lamp via the control board. In this mode, the device will not react to any control signal.

DELAY - With this function you can put the lamp on a delay time.

SPOT - This provides a spot beam for better lamp optimization.

DFSE - This will reset the unit to the default settings.

FEED - With this function you can activate or deactivate the pan/tilt error correction. So if your unit's head gets knocked out of place the unit will automatically go back to the last setting.

FRNS - Select the fan run mode.

HIBE - This feature will automatically shut down the lamp and stepping motors. Please see pages 32-33.

VER - This will display the software version.

ADJU - Fixture code is "C050".

CH01~CH30 for motor calibration.

EDIT MENU -

SEPR (AUTO or IP01 - IP07) - Lets you edit any of the 7 internal programs or auto program.

STEP (Step) - Steps to be used in Edit Programming. See edit program. See page 35.

SCXX (SC01 - SC48) - These are the scenes that are stored in your program. There are a total of 48 scenes.

Submenus:

C-01~C-30 - Edit the channels of each scene.

TIME - Set the Time for each scene.

CEDT - Edit the program via external controller.

REC - This will auto save your custom program.

RUN - This will run your custom program.

On-Board System Menu. The Vizi Spot 5R comes with an easy to navigate system menu. This next section will detail the functions of each command in the system menu.

To access the main menu press the MODE/ESC button (3) on the front of the unit. Tap the UP (4) or DOWN (5) buttons until you reach the function you wish to change. When you reach the function you wish to change tap the ENTER (6) button. Again, tap the UP or DOWN buttons to change the function. Once your changes are made, tap the ENTER button to lock the change in the system, if the ENTER button is not selected within eight seconds the system will automatically return to menu section. To exit without making any changes tap the MODE/ESC button.

ADDR MENU -

ADDR DMX Address Setting via control board -

1. Access the main menu.
2. Tap the UP button until "ADDR" is displayed, press ENTER.
3. "ADD1" will now be displayed. Press the UP or DOWN buttons to find your desired address. Press ENTER to confirm.
4. The display will show "PASS", and then display, your selected address again.

5. Press the MODE/ESC button to return to the main menu.

When the display is on "ADD1", you can directly press the UP or DN buttons to change the DMX start address.

TEST MAIN MENU -

TEST - This will test the functions of each channel.

1. Access the main menu.
2. Tap the UP button until "TEST" is displayed, press ENTER.
3. The display will show "T-01". You can now press the up

button and test the different channels.

4. Press MODE/ESC to exit.

PLAY **MAIN MENU** -

RUN Run the unit in an Auto mode as a “master” in a Master/Slave configuration, or as a stand alone unit -

1. Access the main menu.
2. Tap the UP button until “PLAY” is displayed, press ENTER.
3. Tap the UP button until “RUN” is displayed, press ENTER.
4. Tap the UP or DOWN button to choose between “MASTER” or “ALONE”, select your choice by pressing ENTER, “PASS” will flash in the display and fixture will begin its function.

AUDI Run the unit in Sound Active mode as a “master”, or as a stand alone unit -

1. Access the main menu.
2. Tap the UP button until “PLAY” is displayed, press ENTER.
3. Tap the UP button until “AUDI” is displayed, press ENTER.
4. Tap the UP or DOWN button to choose between “MASTER” or “ALONE”, select your choice by pressing ENTER, “PASS” will flash in the display and fixture will begin its function.

AUTO This is a precaution mode in case you lose the DMX signal. The fixture has 4 modes to choose from, please see page 17 for a description of the 4 modes -

1. Access the main menu by pressing MODE/ESC button.
2. Tap the UP button until “PLAY” is displayed, press ENTER.

3. Tap the UP button until “AUTO” is displayed, press ENTER.
4. Now you can choose between “CLOSE”, “HOLD” “AUTO”, or “AUDI”. “HOLD” is the default setting.
5. Select the mode that you want the fixture to run in case of a lost DMX signal and press ENTER.

LAMP **MAIN MENU** -

OPEN With this function you can switch the lamp on or off via the control board.

1. Access the main menu.
2. Tap the UP button until “LAMP” is displayed, press ENTER.
3. The display will show “ON/OFF”. Press the UP button to select “ON” to switch on the lamp, or “OFF” to switch off the lamp.
4. Press ENTER to confirm.
5. Press MODE/ESC to return to the main menu.

RESE **MAIN MENU** -

ALL With this function you can reset all the motors.

1. Access the main menu.
2. Tap the UP button until “RESE” is displayed, press ENTER.
3. Tap the UP button until “ALL” is displayed, press ENTER.
4. Press ENTER to reset.
5. Press MODE/ESC to return to the main menu.

SCAN With this function you can reset the pan/tilt motors.

1. Access the main menu.

2. Tap the UP button until "RESE" is displayed, press ENTER.
3. Tap the UP button until "SCAN" is displayed, press ENTER.
4. Press ENTER to reset.
5. Press MODE/ESC to return to the main menu.

COLR With this function you can reset the color wheel motor.

1. Access the main menu.
2. Tap the UP button until "RESE" is displayed, press ENTER.
3. Tap the UP button until "COLR" is displayed, press ENTER.
4. Press ENTER to reset.
5. Press MODE/ESC to return to the main menu.

G080 With this function you can reset the gobo wheel motor.

1. Access the main menu.
2. Tap the UP button until "RESE" is displayed, press ENTER.
3. Tap the UP button until "G080" is displayed, press ENTER.
4. Press ENTER to reset.
5. Press MODE/ESC to return to the main menu.

SHTR With this function you can reset the shutter motor.

1. Access the main menu.
2. Tap the UP button until "RESE" is displayed, press ENTER.
3. Tap the UP button until "SHTR" is displayed, press ENTER.
4. Press ENTER to reset.
5. Press MODE/ESC to return to the main menu.

OTHR - When you activate this reset function, the fixture will reset all other motors that are not listed in RESET menu.

1. Access the main menu by pressing MODE/ESC button.
2. Tap the UP button until "RESE" is displayed, press ENTER.
3. Tap the UP button until "OTHR" is displayed.
4. Press ENTER to reset all other motors, or press MODE/ESC to cancel and return to the main menu.

TIME MAIN MENU -

LIFE - With this function you can display the running time of the unit.

1. Access the main menu.
2. Tap the UP button until "TIME" is displayed, press ENTER.
3. Tap the UP button until "LIFE" is displayed, press ENTER.
4. The display shows the running time of the unit.
5. Press MODE/ESC to return to the main menu.

LAMP - With this function you can display the running time of the lamp.

1. Access the main menu.
2. Tap the UP button until "TIME" is displayed, press ENTER.
3. Tap the UP button until "LAMP" is displayed, press ENTER.
4. The display shows the running time of the lamp.
5. Press MODE/ESC to return to the main menu.

CLMP - With this function you can clear the running time of the lamp. **Note Very Important: Please clear the lamp time every time you replace the lamp.**

1. Access the main menu.
2. Tap the UP button until "TIME" is displayed, press ENTER.
3. Tap the UP button until "CLMP" is displayed.
4. Press ENTER to clear the lamp time, or press MODE/ESC to return to the main menu.

RPRN **MAIN MENU** -

RPRN - The movement of the Pan will be reversed.

1. Access the main menu.
2. Tap the UP button until "RPRN" is displayed, press ENTER.
3. The display will show "ON/OFF".
4. Press the UP button to select "ON" to activate this function, or "OFF" to deactivate this function.
5. Press ENTER to confirm.
6. Press MODE/ESC to return to the main menu.

RPRN **MAIN MENU** -

RTILT - The movement of the Tilt will be reversed.

1. Access the main menu.
2. Tap the UP button until "RTILT" is displayed, press ENTER.
3. Press ENTER, the display will show "ON/OFF".
4. Press the UP button to select "ON" to activate this function, or "OFF" to deactivate this function.

5. Press ENTER to confirm.
6. Press MODE/ESC to return to the main menu.

FINE **MENU** -

FINE - Switch between 8bit (coarse) and 16bit (fine) pan & tilt movement. This also switches the DMX Channel mode between 11 channel (8 bit) and 13 channel (16 bit) DMX mode.

1. Access the main menu.
3. Tap the UP button until "FINE" is displayed, press ENTER.
4. Press the UP or DOWN buttons to select either "ON" to activate this function, or "OFF" to deactivate this function.
5. Press ENTER to confirm.
6. Press MODE/ESC to return to the main menu.

DEGR **MENU** -

DEGR - With this function you can switch the Pan degree.

1. Access the main menu.
2. Tap the UP button until "DEGR" is displayed, press ENTER.
3. Press the UP or DOWN buttons to select either "360" or "540".
4. Press ENTER to confirm your selection.
5. Press MODE/ESC to return to the main menu.

MIC **MENU** -

MIC - The internal microphone can be made more or less sensitive.

1. Access the main menu by pressing MODE/ESC button.
3. Tap the UP button until "MIC" is displayed, press ENTER.
4. The display will show "M-01".
5. Press the UP or DOWN button to adjust the microphone sensitivity between "M-01 - M-99".
6. Press ENTER to confirm when you have reached your desired microphone sensitivity level.
7. Press MODE/ESC to return to the main menu.

DISP **MAIN MENU -**

VALU **Display the DMX-512 value of each channel -**

1. Access the main menu.
2. Tap the UP button until "DISP" is displayed, press ENTER.
3. Tap the UP button until "VALU" is displayed, press ENTER.
4. The display should show "0-00". Press the UP button in order to select the desired channel. If you select "0-05" the display will only show the DMX value of the 5th channel
5. Press ENTER to confirm.
6. Press MODE/ESC to return to the main menu.

Now the display will change as per the 5th channel DMX value.

DOON **Shuts off digital display after 2 minutes.**

1. Access the main menu.
2. Tap the UP button until "DISP" is displayed, press ENTER.
3. Tap the UP button until "DOON" is displayed, press ENTER.

4. "CLOI" should now be displayed, press ENTER.
5. The display will show "ON/OFF". Press the UP button to select "ON" to activate this function, or "OFF" to deactivate this function.
6. Press ENTER to confirm.
7. Press MODE/ESC to return to the main menu.

FLIP - **This function will reverse the display 180°.**

1. Access the main menu.
2. Tap the UP button until "DISP" is displayed.
3. Tap the UP button until "FLIP" is displayed.
4. Press ENTER, the display will show "ON/OFF".
5. Press the UP button to select "ON" to activate this function, or "OFF" to deactivate this function.
6. Press ENTER to confirm.
7. Press MODE/ESC to return to the main menu.

LOCK - **With this function you can activate the automatic button lock. When this function is activated, the buttons will automatically lock 15 seconds after the last press of a button. In order to deactivate the button lock, press the MODE/ESC button for 3 seconds.**

1. Access the main menu.
2. Tap the UP button until "DISP" is displayed.
3. Tap the UP button until "LOCK" is displayed, press ENTER.
4. Press the UP or DOWN buttons to select either "ON" to activate this function, or "OFF" to deactivate this function.
5. Press ENTER to confirm.

6. Press MODE/ESC to return to the main menu.

SPEC MAIN MENU -

LAMP With this function the lamp will ignite when power is applied. By default the unit will automatically ignite when power is applied. Use this function to disable that feature.

1. Access the main menu.
2. Tap the UP button until "SPEC" is displayed, press ENTER.
3. Tap the UP button until "LAMP" is displayed, press ENTER.
4. The display will show "ON/OFF". Press the UP button to select "ON" to switch on the lamp, or "OFF" to switch off the lamp.
5. Press ENTER to confirm.
6. Press MODE/ESC to return to the main menu.

DMX With this function you are able to change the DMX address via any DMX controller. This function is factory set to "ON" already.

1. Access the main menu by pressing MODE/ESC.
2. Tap the UP button until "SPEC" is displayed, press ENTER.
3. Tap the UP button until "DMX" is displayed, press ENTER.
4. The display will show "ON/OFF". Press the UP button to select "ON" to activate this function, or "OFF" to deactivate.
5. Press ENTER to confirm, and "PASS" will flash quickly.
6. Press MODE/ESC to return to the main menu.

To use this function follow the instructions:

To adjust the address of your unit you must first go to the address that it is currently set to using your DMX Controller.

From there you can adjust the address, using your DMX Controller. First make sure all channels are set to the value of "0".

1. On your DMX controller set the DMX value of Channel 1 to the value "7".
2. Now set the DMX value of Channel 2 to the value "7" to adjust the starting address between 1 and 255. To adjust the address between 256 and 511 set Channel 2 to the value "8" .
3. Set the DMX value of Channel 3 to your desired starting address. This will take about 20 seconds before the unit accepts the new DMX address.

EXAMPLE: If you want the address to be 57, you must first set the address that is currently assigned to the unit. Then proceed to set Channel 1s' value to "7", Channel 2s' value to "7", and Channel 3s' value to "57".

2ND EXAMPLE: If you want the address to be 420, you must first set the address that is currently assigned to the unit. If you want to set the address to 420, set Channel 1s' value to "7", Channel 2s' value to "8", and Channel 3s to "164". (256 + 164 = 420)

SHUTTER - With this function you can adjust the lamp via the control board. The shutter opens and the lamp can be adjusted. In this mode, the device will not react to any control signal.

1. Access the main menu.
2. Tap the UP button until "SPEC" is displayed, press ENTER.
3. Tap the UP button until "SPOT" is displayed, press ENTER.
4. The display will show "ON/OFF".
5. Press the UP button to select "ON" to activate this function, or "OFF" to deactivate this function.

6. Press ENTER to confirm.
7. Press MODE/ESC to return to the main menu.

DELAY - With this function you can delay the lamp ignition.

1. Access the main menu.
2. Tap the UP button until "SPEC" is displayed, press ENTER.
3. Tap the UP button until "DELAY" is displayed, press ENTER.
4. The display shows "0-00". Press the UP button to select the desired delay between "00" and "59" minutes. For example, if you select "0-03" the lamp will ignite after 3 minutes.
5. Press ENTER to confirm.
6. Press MODE/ESC to return to the main menu.

SPOT - With this function you can adjust the lamp via the control board. The shutter opens and the lamp can be adjusted. In this mode, the device will not react to any control signal.

1. Access the main menu.
2. Tap the UP button until "SPEC" is displayed, press ENTER.
3. Tap the UP button until "SPOT" is displayed, press ENTER.
4. The display will show "ON/OFF".
5. Press the UP button to select "ON" to activate this function, or "OFF" to deactivate this function.
6. Press ENTER to confirm.
7. Press MODE/ESC to return to the main menu.

DFSE - With this function you can restore the factory

settings of the device. All settings will be set back to the default values. Any edited scenes will be lost. When restoring the factory settings the unit must be set to the address that the unit was in when you started editing.

1. Access the main menu.
2. Tap the UP button until "SPEC" is displayed, press ENTER.
3. Tap the UP button until "DFSE" is displayed, press ENTER.
4. The display will show "ON/OFF".
5. Press the UP button to display "ON" to activate this function, or "OFF" to deactivate this function.
6. Press ENTER to confirm.
7. Press MODE/ESC to return to the main menu.

When you exit this function, the unit will begin to reload data.

FEED - Use this function to activate/deactivate the the pan/tilt error correction. When the head is bumped or moved it will return to its previous position.

1. Access the main menu.
2. Tap the UP button until "SPEC" is displayed, press ENTER.
3. Tap the UP button until "FEED" is displayed, press ENTER.
4. The display will show "ON/OFF".
5. Press the UP button to select "ON" to activate this function, or "OFF" to deactivate this function.
6. Press ENTER to confirm.
7. Press MODE/ESC to return to the main menu.

FANS - With this function you can choose between the fan

settings of Auto, High, or Low. The default setting is Low.

1. Access the main menu by pressing MODE/ESC button.
2. Tap the UP button until “FANS” is displayed, press ENTER.
3. Press the UP or DOWN buttons to select either “AUTO”, “HIGH” or “LOW”.
4. Press ENTER to confirm your selection.
5. Press MODE/ESC to return to the main menu.

HIBE - With this function you can make the unit automatically shut down the lamp and stepping motors. The default setting for this is 15 mins. After 15 mins if the unit is not receiving a DMX signal, the unit will automatically shut down the lamp and motors. This feature lengthens the life of the lamp and motors. The shut down time can be adjusted between OFF (no shut down) or 1 - 99 minutes. Once the lamp and motors are shut down, it will reset itself when it receives a DMX signal. When the function is set to OFF, the lamp and motors will not shut down until power is cut.

1. Access the main menu by pressing MODE/ESC button.
2. Tap the UP button until “HIBE” is displayed, press ENTER.
3. Press the UP or DOWN buttons to adjust the shut down time.
4. Press ENTER to confirm your selection.
5. Press MODE/ESC to return to the main menu.

VER - Use this function to display the Software version of the unit.

1. Access the main menu.
2. Tap the UP button until “SPEC” is displayed, press ENTER.

3. Tap the UP button until “VER” is displayed, press ENTER.
4. The display will show “V-X.X”, “X.X” stands for the version number, such as the display may show “V-1.0”, “V-9.9” etc.
5. Press ENTER or MODE/ESC to exit.

ADJU - Use this function is used to make sure all motors are aligned and to adjust any motors that are not.

1. Access the main menu.
2. Tap the UP button until “SPEC” is displayed, press ENTER.
3. Tap the UP button until “ADJU” is displayed, press ENTER.
4. Tap the UP button until “CODE” is displayed, press ENTER.
5. The display will show “CXXX”, were as “XXX” represents the calibration password. The calibration password is “C050.” Use the UP or DOWN buttons to enter the proper password.
6. Once the proper password is entered the display will read “CHXX”, were as “XX” represents the fixture channel number.
7. Select the desired channel to be calibrated by pressing the UP or DOWN buttons and then ENTER to confirm.
8. The display will then read “XXXX”, were “XXXX” stands for the calibrate values.
9. Adjust the desired calibration value between -128 and 127 by pressing the UP and DOWN. As you scroll up and down through the calibration values you will notice slight changes in the wheel or motor you are attempting to calibrate.
10. Once you reach your desired calibration press ENTER to confirm and lock in your calibration.
11. Once you are completely finished press MODE/ESC to return to the main menu.

EDIT - This menu item allows you to write a program into the memory (EEPROM) via the control panel or via the external controller. **Please see pages 38-39 for detailed instructions.**

SEPR (IP01-IP07) - **With this function you can edit any of the internal programs (IP01-IP07) or auto program.**

1. Access the main menu.
2. Tap the UP button until “EDIT” is displayed, press ENTER.
3. Tap the UP button until “SEPR” is displayed, press ENTER.
4. The display will show “IPXX”. “XX” representing 01-07. Tap the UP or DOWN buttons to find your desired program to edit. Press ENTER to edit the chosen program.
5. Press ENTER to save and press MODE/ESC to exit.

STEP - **With this function you can program the number of steps in your individual Program.**

1. Access the main menu.
2. Tap the UP button until “EDIT” is displayed, press ENTER.
3. Tap the UP button until “STEP” is displayed, press ENTER.
4. The display shows “S-01”, this stands for the first step of your program. You can call up to 48 scenes in “Run”. For example, if “S-05” is displayed, it means that “Run” will run the first 5 scenes you saved in “Edit”.
5. Press ENTER to save and press MODE/ESC to exit.

SCXX - **With this function you can choose the number of scenes in your Program. “XX” represents the current scene number that is displayed.**

1. Access the main menu.
2. Tap the UP button until “EDIT” is displayed, press ENTER.

3. Tap the UP button until “SCXX” is displayed. “XX” represents the current scene number that is displayed. You can call up to 48 scenes. For example, if “SC05”, it means that “Run” will run the first 5 scenes you saved in “Edit”

4. Press the ENTER button and either “C-XX”, “TIME”, or “CEDT” will be displayed.
 - When “C-XX” is selected you can edit the channels of each scene.
 - When “TIME” is selected you can edit the time of each scene.
 - When “CEDT” is switched ON, you can edit the program using a DMX controller.
5. Press ENTER when you are done to save and press MODE/ESC to exit.

REC - **With this function you can record the scenes automatically for the external controller.**

1. Access the main menu.
2. Tap the UP button until “EDIT” is displayed, press ENTER.
3. Tap the UP button until “REC” is displayed.
4. The display shows “RE.XX”, “XX” stands for the scene number in the internal memory of where your scenes from the controller will be stored.
5. Press the UP or DOWN button to select your desired scene number.
6. Press ENTER to confirm, and the fixture will record the scenes from the external controller.
7. Press MODE/ESC to return to the main menu.

RUN - **With this function you can run your pre-made pro-**

gram. You can set the number of steps under “STEP”, and you can edit the individual scenes under “EDIT”.

1. Access the main menu.
2. Tap the UP button until “EDIT” is displayed, press ENTER.
3. Tap the UP button until “RUN” is displayed, press ENTER.
4. Press the UP button to display “ON” to activate this function, or “OFF” to deactivate this function.
5. Press ENTER to confirm.
6. Press MODE/ESC to return to the main menu.

Editing procedure 1: Using the control board only.

1. Access the main menu.
2. Tap the UP button until “EDIT” is displayed. Press ENTER.
3. The display will show “SC01”, this stands for the scene number. For example, “SC01” is displayed, it means you will be editing scene 1, press ENTER. You can change the scene number by pressing the UP button.
4. Press ENTER, the display will show “C-XX”, “XX” stands for the channel number displayed. If “C-01” is displayed, you will be editing channel 1 of your selected scene, press ENTER once you have found your desired channel. You can change the channel number by pressing the UP button.
5. The display will show “XXX”. “XXX” represents the displayed DMX value for the channel that is being edited.
6. Adjust the DMX value by pressing the UP button, until you get the expected effect for this channel.
7. Press ENTER to enter the editing of the other channels of the scene.
8. Repeat steps 5-8, until you finish setting all the DMX values for all the channels of this scene, each scene can have 15 channels maximum.
9. Once all the channels are completed, the display will flash “TIME”, this stands for the time needed to run this scene.
10. Press ENTER to edit the time needed, the display shows “T-XX”, “XX” stands for the time needed to run this scene. For example, “T-02” means scene 1 needs 6 seconds to run, “T-15” means scene 5 needs 45 seconds to run.
11. Adjust the time needed by pressing the UP button.
12. Press ENTER to save the settings for the scene you are editing, the display will change to the next scene automatically.

13. Repeat steps 3-12 to edit other scenes, you can edit and save 48 scenes maximum.

14. Press MODE/ESC to exit, now you have edited and saved scenes using the control board. The number of steps can be defined under “Step” and the scenes can be called up under “Run”. To run the scenes see page 36.

Editing procedure 2: Using an external controller.

1. Access the main menu.
2. Tap the UP button until “EDIT” is displayed. Press ENTER.
3. The display will show “SC01”, this stands for the scene number to be edited. For example: If “SC01” is displayed, you will be editing scene 1.
4. Change the scene number by pressing the UP button.
5. Press ENTER, the display will show “C-01”, the “1” stands for the channel number 1.
6. Press the UP button until “CEDT” is displayed, press ENTER.
7. The display will show “OFF”, press the UP button so that “ON” is displayed, press ENTER.
8. The display shows “SC02”. You have successfully downloaded the first scene.
9. Adjust the Step-time. needed by pressing the UP button.
10. Call up the second scene in your controller now.
11. Repeat steps 3-6 until all desired scenes are downloaded.
12. Press MODE/ESC to exit. The number of steps can be defined under “Step” and the scenes can be called up under “Run”.

When power is applied, the unit will automatically enter a “reset/test” mode. This mode brings all the internal motors to a home position. If there is an internal problem with one or more of the motors an error code will flash in the display in the form of “XXEr”, “XX” will represent a function number. For example, when the display shows “03Er,” it means there is some type of error with the channel 3 motor. If there are multiple errors during the start-up process they will all flash in the display. For example: if the fixtures has errors on channel 1 and channel 3 all at the same time, you will see the error message flash “01Er”, and “03Er repeated 5 times.

If an error does occur during the initial start-up procedure the fixture will self-generate a second reset signal and try to realign all the motors and correct the errors, if the errors persist after a second attempt a third attempt will be made.

If after a third attempt all the errors have not been corrected the fixture will make the following determinations:

- 1) 3 or more errors - The fixture cannot function properly with three or more errors therefore the fixture will place itself in a stand-by mode until subsequent repairs can be made.
- 2) Less than 3 errors - If the fixture has less than 3 errors, therefore most other functions will work properly. The fixture will attempt to operate normally until the errors can be corrected by a technician. The errors in question will remain flashing in the display as a reminder of internal errors.

01Er – PAN movement error:

This message will appear after a fixture reset, if the pan-yoke’s magnetic-indexing circuit malfunctions (sensor failed or magnet is missing) or there is a stepper motor failure (defective motor or a defective motor IC drive on the main PCB).

03Er – TILT movement error:

This message will appear after a fixture reset, if the tilt magnetic-indexing circuit malfunctions (sensor failed or magnet is

missing) or there is a stepper motor failure (defective motor or a defective motor IC drive on the main PCB).

05Er – COLOR WHEEL error:

This message will appear after a fixture reset, if the head's magnetic-indexing circuit malfunctions (sensor failed or magnet is missing) or there is a stepper motor failure (defective motor or a defective motor IC drive on the main PCB).

06Er – ROTATING GOBOS error:

This message will appear after a fixture reset, if the magnetic-indexing circuit malfunctions (sensor failed or magnet is missing) or there is a stepper motor failure (defective motor or a defective motor IC drive on the main PCB).

07Er – GOBO ROTATING error:

This message will appear after a fixture reset, if the magnetic-indexing circuit malfunctions (sensor failed or magnet is missing) or there is a stepper motor failure (defective motor or a defective motor IC drive on the main PCB).

09Er – FOCUS error:

This message will appear after a fixture reset, if the magnetic-indexing circuit malfunctions (sensor failed or magnet is missing) or there is a stepper motor failure (defective motor or a defective motor IC drive on the main PCB).

Operating Modes: *The Vizi Spot 5R can operate in three different modes. This next section will detail the differences in the operating modes.*

- **Stand alone mode -**

The unit will react to sound, chasing through the built-in programs.

- **Master/Slave mode -**

You can daisy chain up to 16 units together to get a synchronized light show without the need of an external controller. The units will react to sound chasing through the several built-in programs.

- **DMX control mode -**

This function will allow you to control each individual fixtures traits with a standard DMX-512 controller such as the Elation® Show Designer.™

Universal DMX Control: This function allows you to use a universal DMX-512 controller such as the Elation® DMX Operator™ or Elation® Show Designer™ to control head movement, the color wheel, gobo wheel, and the shutter (strobe). A DMX controller allows you to create unique programs tailored to your individual needs.

1. The Vizi Spot 5R uses 11 or 13 DMX channels, depending on what mode you are in. See pages 44-51 for detailed description of the DMX traits.
2. To control your fixture in DMX mode, follow the set-up procedures on pages 13-15 as well as the set-up specifications that are included with your DMX controller.
3. Use the controller's faders to control the various DMX fixture traits.
4. This will allow you to create your own programs.
5. Follow the instruction on page 20 to set the DMX address.
6. For longer cable runs (more than a 100 feet) use a terminator on the last fixture.
7. For help operating in DMX mode consult the manual included with your DMX controller.

Stand-Alone (Sound Active or Auto Program): This mode allows a single unit to run to the beat of the music or run through a built-in program.

1. Access the main menu.
2. Tap the UP button until "PLAY" is displayed, and Press ENTER.

Vizi Spot 5R**Operation**

3. Tap the UP button until "AUTO" is displayed, and Press ENTER.
4. Press UP, to select "RUN", or "AUDIO". "RUN" will make the unit run through a built-in program. "AUDIO" will make the unit sound active.
5. Press UP, to select "ALONE" or "MASTER". Which means stand alone, or master/slave mode.
6. Select a mode, and press ENTER to confirm.
7. Press MODE/ESC if you want to return to the main menu.
8. You may change the show or invert the pan and tilt functions in the system menu by following the directions on page 25.

Master-Slave Operation (Sound Active or Auto Program):

This function will allow you to link up to 16 units together and operate without a controller. The units can run a built-in program or run in sound active mode. In Master-Slave operation one unit will act as the controlling unit and the others will react to the controlling units programs. Any unit can act as a Master or as a Slave.

1. Using standard XLR microphone cables, daisy chain your units together via the XLR connector on the rear of the units. Remember the Male XLR connector is the input and the Female XLR connector is the output. The first unit in the chain (master) will use the female XLR connector only - The last unit in the chain will use the male XLR connector only. For longer cable runs we suggest a terminator at the last fixture.
2. Access the main menu.
2. Tap the UP button until "PLAY" is displayed, and Press ENTER.
3. Tap the UP button to choose between "RUN" or "AUDIO". "RUN" will make the units run through a built-in program. "AUDIO" will make the units sound active.
4. Press UP, to select "ALONE" or "MASTER". Which means stand alone, or master/slave mode.
5. Select "MASTER" to set the unit as the Master, and press ENTER to confirm. Now all the connected units will follow the Master.
6. Press MODE/ESC if you want to return to the main menu.
7. You may change the show or invert the pan and tilt functions in the system menu by following the directions on page 25.

Vizi Spot 5R**11 Channel DMX Mode**

| Channel | Value | Function |
|---------|---|---|
| 1 | 0 - 255 | PAN MOVEMENT 8bit |
| 2 | 0 - 255 | TILT MOVEMENT 8bit |
| 3 | 0 - 13 14 - 27 28 - 41 42 - 55 56 - 69 70 - 83 84 - 97 98 - 111 112 - 127 128 - 189 190 - 193 194 - 255 | <u>COLOR WHEEL</u> OPEN COLOR 1 COLOR 2 COLOR 3 COLOR 4 COLOR 5 COLOR 6 COLOR 7 COLOR 8 FORWARD RAINBOW EFFECT FAST - SLOW NO ROTATION BACKWARDS RAINBOW EFFECT SLOW - FAST |
| 4 | 0 - 9 10 - 19 20 - 29 30 - 39 40 - 49 50 - 59 60 - 69 70 - 79 80 - 89 90 - 104 105 - 119 120 - 134 135 - 149 150 - 164 165 - 179 180 - 194 | <u>GOBOS</u> OPEN ROTATING GOBO 1 ROTATING GOBO 2 ROTATING GOBO 3 ROTATING GOBO 4 ROTATING GOBO 5 ROTATING GOBO 6 ROTATING GOBO 7 ROTATING GOBO 8 ROTATING GOBO 1 SHAKE ROTATING GOBO 2 SHAKE ROTATING GOBO 3 SHAKE ROTATING GOBO 4 SHAKE ROTATING GOBO 5 SHAKE ROTATING GOBO 6 SHAKE ROTATING GOBO 7 SHAKE |

| Vizi Spot 5R | | 11 Channel DMX Mode |
|--------------|--|--|
| Channel | Value | Function |
| 4 | 195 - 209 210 - 255 | <u>GOBOS CONT.</u> ROTATING GOBO 8 SHAKE CONTINUOUS ROTATION OF GOBO WHEEL SLOW - FAST |
| 5 | 0 - 127 128 - 189 190 - 193 194 - 255 | <u>GOBO INDEXING & ROTATION</u> GOBO INDEXING FORWARDS GOBO ROTATION FAST - SLOW NO ROTATION BACKWARDS GOBO ROTATION SLOW - FAST |
| 6 | 0 - 3 4 - 63 64 - 67 68 - 127 128 - 135 136 - 143 144 - 151 152 - 159 160 - 167 168 - 175 176 - 183 184 - 191 192 - 199 200 - 207 208 - 215 216 - 223 224 - 231 232 - 239 240 - 247 248 - 255 | <u>3 FACET PRISM/GOBO MACROS</u> OPEN PRISM FORWARD ROTATION FAST - SLOW NO ROTATION PRISM BACKWARDS ROTATION SLOW - FAST MACRO 1 MACRO 2 MACRO 3 MACRO 4 MACRO 5 MACRO 6 MACRO 7 MACRO 8 MACRO 9 MACRO 10 MACRO 11 MACRO 12 MACRO 13 MACRO 14 MACRO 15 MACRO 16 |

| Vizi Spot 5R | | 11 Channel DMX Mode |
|--------------|---|---|
| Channel | Value | Function |
| 7 | 0 - 255 | <u>FOCUS</u> ADJUSTMENT FAR - NEAR |
| 8 | 0 - 31 32 - 63 64 - 95 96 - 127 128 - 159 160 - 191 192 - 223 224 - 255 | <u>SHUTTER & STROBE</u> SHUTTER CLOSED SHUTTER OPEN STROBING SLOW - FAST SHUTTER OPEN PULSE EFFECT IN SEQUENCES SHUTTER OPEN RANDOM STROBE SLOW - FAST SHUTTER OPEN |
| 9 | 0 - 255 | <u>DIMMER</u> INTENSITY 0% - 100% |
| 10 | 0 - 225 226 - 235 236 - 245 246 - 255 | <u>PAN/TILT MOVEMENT SPEED</u> MAX TO MIN. SPEED BLACKOUT BY MOVEMENT BLACKOUT BY WHEEL CHANGING NO FUNCTION |
| 11 | 0 - 19 20 - 29 30 - 39 40 - 59 60 - 79 80 - 84 85 - 87 88 - 90 91 - 93 94 - 96 97 - 99 100 - 119 120 - 139 140 - 159 | <u>RESET & INTERNAL PROGRAMS</u> COLOR CHANGE NORMAL COLOR CHANGE TO ANY POSITION COLOR & GOBO CHANGE TO ANY POSITION LAMP ON LAMP OFF ALL MOTOR RESET SCAN MOTOR RESET COLOR MOTOR RESET GOBO MOTOR RESET SHUTTER/DIMMER MOTOR RESET OTHER MOTOR RESET INTERNAL PROGRAM 1 INTERNAL PROGRAM 2 INTERNAL PROGRAM 3 |

| Vizi Spot 5R | | 11 Channel DMX Mode |
|--------------|-----------|--------------------------------------|
| Channel | Value | Function |
| 11 | | <u>RESET & INTERNAL PROGRAMS</u> |
| | 160 - 179 | INTERNAL PROGRAM 4 |
| | 180 - 199 | INTERNAL PROGRAM 5 |
| | 200 - 219 | INTERNAL PROGRAM 6 |
| | 220 - 239 | INTERNAL PROGRAM 7 |
| | 240 - 255 | SOUND ACTIVE PROGRAM |

| Vizi Spot 5R | | 13 Channel DMX Mode |
|--------------|-----------------------|---|
| Channel | Value | Function |
| 1 | 0 - 255 | PAN MOVEMENT 8bit |
| 2 | 0 - 255 | PAN FINE 16bit |
| 3 | 0 - 255 | TILT MOVEMENT 8bit |
| 4 | 0 - 255 | TILT FINE 16bit |
| 5 | | <u>COLOR WHEEL</u> |
| | 0 - 14 | OPEN |
| | 15 - 29 | COLOR 1 |
| | 30 - 44 | COLOR 2 |
| | 45 - 59 | COLOR 3 |
| | 60 - 74 | COLOR 4 |
| | 75 - 89 | COLOR 5 |
| | 90 - 104 | COLOR 6 |
| | 105 - 119 | COLOR 7 |
| | 120 - 127 | COLOR 8 |
| | 128 - 189 | FORWARD RAINBOW EFFECT FAST - SLOW |
| | 190 - 193 | NO ROTATION |
| | 194 - 255 | BACKWARDS RAINBOW EFFECT SLOW - FAST |
| 6 | | <u>GOBOS</u> |
| | 0 - 9 | OPEN |
| | 10 - 19 | ROTATING GOBO 1 |
| | 20 - 29 | ROTATING GOBO 2 |
| | 30 - 39 | ROTATING GOBO 3 |
| | 40 - 49 | ROTATING GOBO 4 |
| | 50 - 59 | ROTATING GOBO 5 |
| | 60 - 69 | ROTATING GOBO 6 |
| | 70 - 79 | ROTATING GOBO 7 |
| | 80 - 89 | ROTATING GOBO 8 |
| | 90 - 104 | ROTATING GOBO 1 SHAKE |
| | 105 - 119 | ROTATING GOBO 2 SHAKE |
| | 120 - 134 | ROTATING GOBO 3 SHAKE |
| 135 - 149 | ROTATING GOBO 4 SHAKE | |

| Vizi Spot 5R | | 13 Channel DMX Mode |
|--------------|-----------|--|
| Channel | Value | Function |
| 6 | 150 - 164 | <u>GOBOS CONT.</u> ROTATING GOBO 5 SHAKE |
| | 165 - 179 | ROTATING GOBO 6 SHAKE |
| | 180 - 194 | FOTATING GOBO 7 SHAKE |
| | 195 - 209 | ROTATING GOBO 8 SHAKE |
| | 210 - 255 | CONTINIOUS ROTATION OF GOBO WHEEL SLOW - FAST |
| | 7 | 0 - 127 |
| 128 - 189 | | FORWARDS GOBO ROTATION FAST - SLOW |
| 190 - 193 | | NO ROTATION |
| 194 - 255 | | BACKWARDS GOBO ROTATION SLOW - FAST |
| 8 | | 0 - 3 |
| | 4 - 63 | PRISM FORWARD ROTATION FAST - SLOW |
| | 64 - 67 | NO ROTATION |
| | 68 - 127 | PRISM BACKWARDS ROTATION SLOW - FAST |
| | 128 - 135 | MACRO 1 |
| | 136 - 143 | MACRO 2 |
| | 144 - 151 | MACRO 3 |
| | 152 - 159 | MACRO 4 |
| | 160 - 167 | MACRO 5 |
| | 168 - 175 | MACRO 6 |
| | 176 - 183 | MACRO 7 |
| | 184 - 191 | MACRO 8 |
| | 192 - 199 | MACRO 9 |
| | 200 - 207 | MACRO 10 |
| | 208 - 215 | MACRO 11 |
| | 216 - 223 | MACRO 12 |
| 224 - 231 | MACRO 13 | |

| Vizi Spot 5R | | 13 Channel DMX Mode |
|--------------|-----------|--|
| Channel | Value | Function |
| 8 | 232 - 239 | <u>3 FACET PRISM/GOBO MACROS</u> MACRO 14 |
| | 240 - 247 | MACRO 15 |
| | 248 - 255 | MACRO 16 |
| | 9 | 0 - 255 |
| 10 | | 0 - 31 |
| | 32 - 63 | SHUTTER OPEN |
| | 64 - 95 | STROBING SLOW - FAST |
| | 96 - 127 | SHUTTER OPEN |
| | 128 - 159 | PULSE EFFECT IN SEQUENCES |
| | 160 - 191 | SHUTTER OPEN |
| | 192 - 223 | RANDOM STROBE SLOW - FAST |
| | 224 - 255 | SHUTTER OPEN |
| 11 | 0 - 255 | <u>DIMMER</u> INTENSITY 0% - 100% |
| | 12 | 0 - 225 |
| 226 - 235 | | BLACKOUT BY MOVEMENT |
| 236 - 245 | | BLACKOUT BY WHEEL CHANGING |
| 246 - 255 | | NO FUNCTION |
| 13 | | 0 - 19 |
| | 20 - 29 | COLOR CHANGE TO ANY POSITION |
| | 30 - 39 | COLOR & GOBO CHANGE TO ANY POSITION |
| | 40 - 59 | LAMP ON |
| | 60 - 79 | LAMP OFF |
| | 80 - 84 | ALL MOTOR RESET |
| | 85 - 87 | SCAN MOTOR RESET |
| | 88 - 90 | COLOR MOTOR RESET |
| | 91 - 93 | GOBO MOTOR RESET |
| | 94 - 96 | SHUTTER/DIMMER MOTOR RESET |

| Vizi Spot 5R | | 13 Channel DMX Mode |
|--------------|----------------------|--------------------------------------|
| Channel | Value | Function |
| 13 | | <u>RESET & INTERNAL PROGRAMS</u> |
| | 97 - 99 | OTHER MOTOR RESET |
| | 100 - 119 | INTERNAL PROGRAM 1 |
| | 120 - 139 | INTERNAL PROGRAM 2 |
| | 140 - 159 | INTERNAL PROGRAM 3 |
| | 160 - 179 | INTERNAL PROGRAM 4 |
| | 180 - 199 | INTERNAL PROGRAM 5 |
| | 200 - 219 | INTERNAL PROGRAM 6 |
| | 220 - 239 | INTERNAL PROGRAM 7 |
| 240 - 255 | SOUND ACTIVE PROGRAM | |

Vizi Spot 5R Gobo Replacement

This unit comes with interchangeable gobos. When changing the gobos please be very careful. Follow the instructions below.

Caution! *Never open the unit when in use. Always disconnect the main power before attempting to change the gobos.*

1. To change the gobo, you must remove the bottom half of the moving head. The bottom half of the moving head does not have the lens in front. The lens is on the top half of the head.
2. Unscrew the 4 phillips screws that secure the bottom half shell. The screws will “pop” up when loose, they cannot be removed. Remove the bottom half of the shell.
3. When you remove the shell you will be able to access the gobo wheel. Turn the wheel with your hand until you come across the gobo you would like to change.
4. You have to remove the individual gobo assembly. Using a pair of pliers, grab the small metal tab that sticks up from the gobo frame assembly, and gently pull the gobo assembly out.
5. Once the gobo frame has been removed, remove the fixture-ring and gobo. Be very careful removing the fixture-ring, it can “spring” out.
6. Change the gobo, replace the fixture-ring. When inserting the gobo assembly back into the unit, the bottom of the gobo assembly must slide underneath the metal place holder located near the bottom of the gobo wheel.
7. Reassemble the unit.

Caution: Always replace with the exact same type lamp and fuse, unless otherwise specified by an authorized American DJ® service technician. Replacing with anything other than the specified part can damage your unit and will void your manufactures warranty.

Warning: If you continue to blow lamps or fuses, STOP using the unit. Contact customer support for further instructions, you may have to return the unit for servicing. Continuing to use the unit may cause serious damage.

Lamp Replacement: Caution! Never attempt to change the lamp while the fixture is plugged in. Always disconnect the main power and allow the unit ample time to cool before attempting to replace the lamp. Please see page 7 for important information regarding the discharge lamp.

1. Be sure to follow the proper handling procedures that deal with discharge lamps.
2. Remove the two small screws (A,B) on the rear of the unit
3. After removing the screws, remove the panel.
4. **Loosen** the 4 phillips screws that hold the lamp in place. Once the screw are loose, gently turn the lamp counter-clockwise to release the lamp from the holder.
5. Replace the lamp with an exact match, then gently turn the lamp clockwise to situate the lamp into the holder and tighten the screws that hold the lamp in place. Reassemble in reverse order.

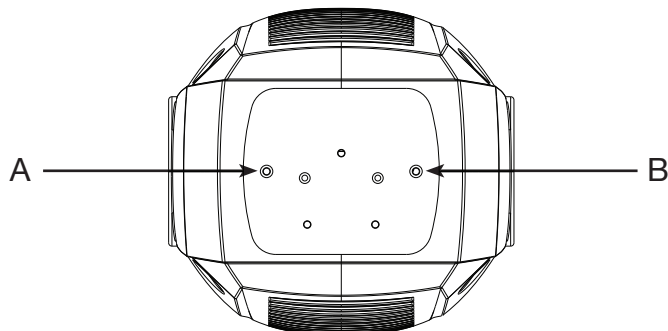

Fuse Replacement: First unplug the power. The fuse holder is located next to the power cord. Using a flat-head screw driver unscrew the fuse holder. Remove the bad fuse and replace with a new one.

Fixture Cleaning: Due to fog residue, smoke, and dust cleaning the internal and external optical lenses and mirror should be carried out periodically to optimize light output. Cleaning frequency depends on the environment in which the fixture operates (I.e. smoke, fog residue, dust, dew). In heavy club use we recommend cleaning on a monthly basis. Periodic cleaning will ensure longevity, and crisp output.

1. Use normal glass cleaner and a soft cloth to wipe down the outside casing.
2. Use a brush to wipe down the cooling vents and fan grill.
3. Clean the external optics and mirror with glass cleaner and a soft cloth every 20 days.
4. Clean the internal optics with glass cleaner and a soft cloth every 30-60 days.
5. Always be sure to dry all parts completely before plugging the unit back in.

Trouble Shooting: Listed below are a few common problems that you may encounter, with solutions.

No light output from the unit;

1. Be sure you have connected your unit into a standard 120v wall outlet.
2. Be sure the external fuse has not blown. The fuse is located on the bottom panel of the unit.
3. Remove the lamp holder and be sure the lamp is seated in its socket properly. Occasionally lamps become loose during shipping be sure the lamp is push in to its socket all the way.
4. Be sure the fuse holder is completely and properly seated.

Unit does not respond to sound;

1. Low frequencies (bass) should cause the unit to react to sound. Tapping on the microphone, quiet or high pitched sounds may not activate the unit.

Vizi Spot 5R

Warranty

MANUFACTURER'S LIMITED WARRANTY

A. American DJ, Inc. hereby warrants, to the original purchaser, American DJ and American Audio products to be free of manufacturing defects in material and workmanship for a prescribed period from the date of purchase (see specific warranty period on reverse). This warranty shall be valid only if the product is purchased within the United States of America, including possessions and territories. It is the owner's responsibility to establish the date and place of purchase by acceptable evidence, at the time service is sought.

B. For warranty service you must obtain a Return Authorization number (RA#) before sending back the product. Contact American DJ, Inc. Service Department at 800-322-6337. Send the product only to the American DJ, Inc. factory. All shipping charges must be pre-paid. If the requested repairs or service (including parts replacement) are within the terms of this warranty, American DJ, Inc. will pay return shipping charges only to a designated point within the United States. If the entire instrument is sent, it must be shipped in its original package. No accessories should be shipped with the product. If any accessories are shipped with the product, American DJ, Inc. shall have no liability whatsoever for loss of or damage to any such accessories, nor for the safe return thereof.

C. This warranty is void if the serial number has been altered or removed; if the product is modified in any manner which American DJ, Inc. concludes, after inspection, affects the reliability of the product; if the product has been repaired or serviced by anyone other than the American DJ, Inc. factory unless prior written authorization was issued to purchaser by American DJ, Inc.; if the product is damaged because not properly maintained as set forth in the instruction manual.

D. This is not a service contract, and this warranty does not include maintenance, cleaning or periodic check-up. During the period specified above, American DJ, Inc. will replace defective parts at its expense with new or refurbished parts, and will absorb all expenses for warranty service and repair labor by reason of defects in material or workmanship. The sole responsibility of American DJ, Inc. under this warranty shall be limited to the repair of the product, or replacement thereof, including parts, at the sole discretion of American DJ. All products covered by this warranty were manufactured after January 1, 1990, and bear identifying marks to that effect.

E. American DJ, Inc. reserves the right to make changes in design and/or improvements upon its products without any obligation to include these changes in any products theretofore manufactured. No warranty, whether expressed or implied, is given or made with respect to any accessory supplied with products described above. Except to the extent prohibited by applicable law, all implied warranties made by American DJ, Inc. in connection with this product, including warranties of merchantability or fitness, are limited in duration to the warranty period set forth above. And no warranties, whether expressed or implied, including warranties of merchantability or fitness, shall apply to this product after said period has expired. The consumer's and/or Dealer's sole remedy shall be such repair or replacement as is expressly provided above; and under no circumstances shall American DJ, Inc. be liable for any loss or damage, direct or consequential, arising out of the use of, or inability to use, this product.

This warranty is the only written warranty applicable to American DJ and American Audio Products and supersedes all prior warranties and written descriptions of warranty terms and conditions heretofore published.

MANUFACTURER'S LIMITED WARRANTY PERIODS:

- All American Audio Products = 1-year (365 day) Limited Warranty (except V-Plus Series Amplifiers)
- All American Audio V-Plus Series Amplifiers = 3-year (1095 day) Limited Warranty
- American DJ Lighting and American DJ Branded Products = 1-year (365 day) Limited Warranty (Such as: Special Effect Lighting, Intelligent Lighting, UV lighting, Strobos, Fog Machines, Bubble Machines, Mirror Balls, Par Cans, Trussing, Lighting Stands etc. excluding Laser Products, lamps, and Star Tec Series)
- American DJ Laser Products and Star Tec Products = 90-Day Limited Warranty
- American DJ L.E.D. Products = 3-year (1095 day) Limited Warranty (excluding motors, PCB boards, and power supplies, which have a 1-year (365 day Limited Warranty).

American DJ® - www.americandj.com - Vizi Spot 5R Instruction Manual Page 55

Vizi Spot 5R

Specifications

| | |
|--------------------------|---|
| Model: | Vizi Spot 5R |
| Voltage: | 100~240V, 50/60Hz |
| Lamp: | Philips® Platinum 5R Discharge* |
| Dimensions: | 335mm x 310mm x 448mm |
| Colors: | 8 Plus White |
| Gobos: | 8 Rotating + Spot - All Replaceable 4 x Metal, 4 x Glass 13.8mm Outside 9.0mm Viewable 0.3mm (Metal Gobo Thickness) 2.2mm (Glass Gobo Thickness) |
| Weight: | 27 Lbs. / 12 kgs. |
| Fuse: | 5A (120v) / 3A (230v) |
| Duty Cycle: | None |
| DMX: | 11 or 13 Channels |
| Sound Active: | Yes |
| Working Position: | Any Safe, Secure Position |
| Warranty: | 1 Year (365 days) |

*This lamp has a 2000 hour life please see page 7 for more info.

Auto Sensing Voltage: *This fixture contains a electronic ballast, which will auto sense the voltage when it is plugged into the power source.*

Please Note: *Specifications and improvements in the design of this unit and this manual are subject to change without any prior written notice.*

©American DJ Supply

American DJ World Headquarters:

6122 S. Eastern Ave. Los Angeles, CA 90040 USA

Tel: 323-582-2650 / Fax: 323-725-6100

Web: www.americandj.com / E-mail: info@americandj.com

American DJ Europe

Junostraat 2

6468 EW Kerkrade

Netherlands

Follow Us On:



facebook.com/americandj
twitter.com/americandj
youtube.com/adjlighting

service@adjgroup.eu / www.americandj.eu

Tel: +31 45 546 85 00 / Fax: +31 45 546 85 99