

American DJ®  
**WHIRL 250**



## User Instructions

American DJ®  
4295 Charter Street  
Los Angeles, CA. 90058  
www.americandj.com

12/03

### Whirl 250™

### General Introduction

**Unpacking:** Thank you for purchasing the Whirl 250™ by American DJ®. Every Whirl 250™ has been thoroughly tested and has been shipped in perfect operating condition. Carefully check the shipping carton for damage that may have occurred during shipping. If the carton appears to be damaged, carefully inspect your unit for any damage and be sure all equipment necessary to operate the unit has arrived intact. In the event damage has been found or parts are missing, please contact our toll free customer support number for further instructions. Please do not return the unit to your dealer without first contacting customer support.

**Introduction:** Thank you for purchasing the American DJ® Whirl 250™. The Whirl 250™ is a unique rotating-gobo fixture. The unit comes with one interchangeable gobo that rotates continuously. When the gobo is removed the unit will operate as "moon flower." The unit has 3-way mode switch that allows the unit to be operated in three different modes (see page 7 for operating modes). To optimize beam intensity use this fixture with a fog machine or other type of special effect smoke.

**Customer Support:** American DJ® provides a toll free customer support line, to provide set up help and to answer any question should you encounter problems during your set up or initial operation. You may also visit us on the web at [www.americandj.com](http://www.americandj.com) for any comments or suggestions. For service related issue please contact American DJ®. Service Hours are Monday through Friday 9:00 a.m. to 5:00 p.m. Pacific Standard Time.

Voice: (800) 322-6337

Fax: (323) 582-2610

E-mail: [support@americandj.com](mailto:support@americandj.com)

To purchase parts online visit <http://parts.americandj.com>

**Warning!** To prevent or reduce the risk of electrical shock or fire, do not expose this unit to rain or moisture.

**Caution!** There are no user serviceable parts inside this unit. Do not attempt any repairs yourself, doing so will void your manufactures warranty. In the unlikely event your unit may require service please contact American DJ.

**PLEASE recycle the shipping carton whenever possible.**

## Whirl 250™

## General Instructions

Please carefully read and understand the instructions in this manual thoroughly before attempting to operate this unit. These instructions contain important safety information regarding the use and maintenance of this unit. Please keep this manual with the unit, for future reference.

## Whirl 250™

## Features

- Replaceable Rotating Gobo
- Easy Lamp Replacement
- ZB-ELC 24V/250W
- Compact High-Tech Case Design
- Built-In Hanging Yoke
- Internal Microphone
- Fan Cooled
- Multi-Colored Beams
- 3-Way Effects Switch - 3 Operating Modes
- Sound Active

## Whirl 250™

## Warranty Registration

The Whirl 250™ carries a one year (365 days) limited warranty. Please fill out the enclosed warranty card to validate your purchase. All returned service items whether under warranty or not, must be freight pre-paid and accompany a return authorization (R.A.) number. If the unit is under warranty you must provide a copy of your proof of purchase invoice. Please contact American DJ® customer support for a R.A. number.

## Whirl 250™

## Halogen Lamp Warning

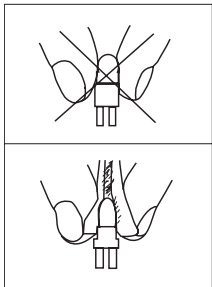

**Halogen Lamp Warning!** This fixture is fitted with halogen lamps which are highly susceptible to damage if improperly handled. Never touch the lamps with your bare fingers as the oil from your hands will shorten lamp life. Also, never move the fixture until the lamps have had ample time to cool. Remember, lamps are not covered under warranty conditions.

## Whirl 250™

## Precautions

**Safety Issues:** This unit may blow the breaker if the maximum allotted load of 5 amps is reached. If the breaker needs replacement, always replace the breaker with same exact type that was removed, unless otherwise instructed by an authorized American DJ® service technician. Use of a different type breaker from that which is recommended may cause fire or electric shock and will void the manufacturer's warranty.

- To reduce the risk of electrical shock or fire, do not expose this unit to rain or moisture
- Do not spill water or other liquids into or on to your unit
- Do not attempt to operate this unit if the power cord has been frayed or broken
- Do not attempt to remove or break off the ground prong from the electrical cord. This prong is used to reduce the risk of electrical shock and fire in case of an internal short
- Disconnect from main power before making any type of connection
- Do not remove the cover under any conditions. There are no user serviceable parts inside
- Never plug this unit into a dimmer pack
- Always be sure to mount this unit in an area that will allow proper ventilation. Allow about 6" (15cm) between this device and a wall
- Do not attempt to operate this unit, if it becomes damaged
- This unit is intended for indoor use only, use of this product outdoors voids all warranties
- During long periods of non-use, disconnect the unit's main power
- Always mount this unit in safe and stable manner
- Power cords should be routed so they are not likely to be walked on, pinched by items placed upon or against them.
- Cleaning -The fixture should be cleaned only as recommended by the manufacturer. See page 9 for cleaning details
- Heat -The appliance should be situated away from heat sources such as radiators, heat registers, stoves, or other appliances (including amplifiers) that produce heat.
- The fixture should be serviced by qualified service personnel when:
  - A. The power-supply cord or the plug has been damaged.
  - B. Objects have fallen, or liquid has been spilled into the unit.
  - C. The unit has been exposed to rain or water.
  - D. The unit does not appear to operate normally or exhibits a marked change in performance.

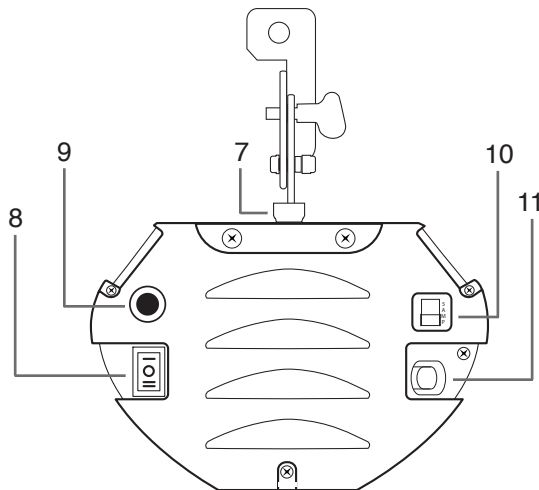
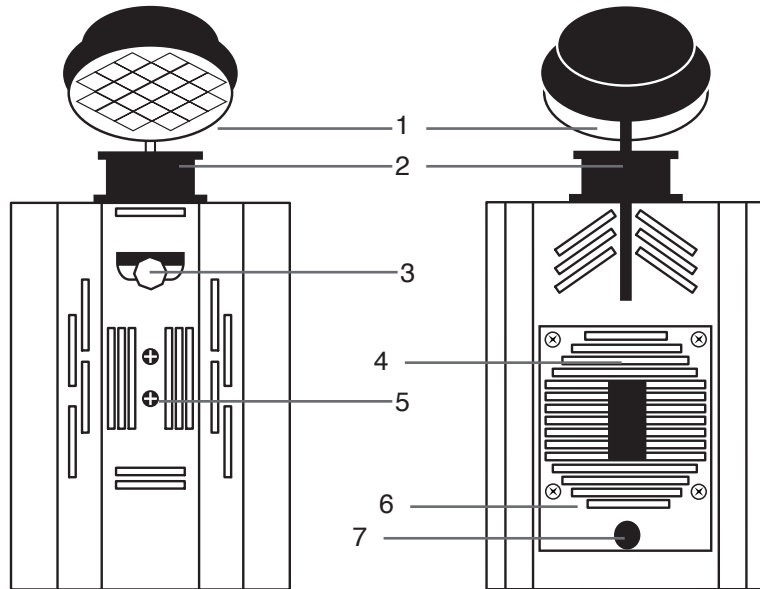

**1. Mirror** - This is a highly reflective surface mirror specifically designed to optimize and enhance beam output. Never use glass cleaner that contains ammonia to clean the surface of the mirror (such as Windex).

**2. Lens** - This is a fully focusing high quality lens. Focus the lens by manually turning the lens in a clockwise or counter-clockwise direction.

**3. Glass Filter** - This unit comes with a built-in glass filter. This filter may be removed at any time for a completely different effect. To remove the filter unscrew the retaining thumb screw and gently pull the filter out.

**4. Fan** - Cooling fan. For optimal performance keep this fan grill clean at all times.

**5. Lamp Assembly Retaining Screws** - These two screws hold the lamp assembly in place.

**6. Lamp Assembly Cover** - This plate accesses the lamp socket assembly. This cover is held securely in place by a single thumb screw. The fan is also attached to this cover.

**7. Lamp Cover Retaining Screw** - This thumb screw holds the lamp socket assembly cover into place.

**8. Function Switch** - This is a 3-way function switch. This unit can be operated in three different modes all of which are controlled by this switch.

**9. Microphone** - This microphone receives external low frequencies to trigger the unit.

**10. Breaker** - A 5A built-in safety breaker to reduce the risk of electrical shock or fire and protect the circuitry. In the case of an internal short or power surge.

**11. Power Cord** - Connect only to a matching power outlet. Never use this fixture if the ground prong has been removed or broken off.

**Power Supply:** Before plugging your unit in, be sure the source voltage in your area matches the required voltage for your American DJ® Whirl 250™ before attempting operation.

**General Operation:** Just plug this light in, and watch it go. This fixture is designed to operate as a stand alone unit. It has been tested and the lamp has been installed at the factory there is no assembly necessary. The Whirl 250™ is ready to be plugged in, out of the box. There is no power switch, after plugging the unit the unit's internal beveled glass wheel will rotate continuously in a single direction, while the outside color dish will rotate back and forth to the beat of music. The unit will create multi-colored patterns that will simulate the rippling effect of water. If there is no lamp output check the breaker and bulb. If the breaker and bulb are good, please return the unit for servicing.

### Operating Modes:

This unit comes with a 3-way multi-operating switch located on the rear of the unit. The switch controls three (3) different operating modes; Static, Sound Active, and Continuous Rotation.

Switch in the "I" position: Mode 1 - In this mode the gobo wheel and the external mirror dish will spin continuously in one direction, regardless of the presence of sound.

Switch in the "0" position: Mode 2 - In this mode the gobo wheel will continuously rotate while the external mirror dish will remain static. In this mode the unit may be used as a rotating-gobo projector.

Switch in the "II" position: Mode 3 - In the this mode the gobo wheel will continuously rotate in one direction while the outer mirror dish will react to sound. Please note that tapping on the unit, or high pitched sounds may not trigger the unit, the unit is designed to react to low frequencies (bass). Also note that the music sensitivity is preset at the factory and may not be changed or adjusted.

### Focusing:

The unit has a fully focusing lens. The lens is focused by manually turning the lens in either a clockwise or counter-clockwise direction.

**Caution:** Always replace with the exact same type lamp, unless otherwise specified by an authorized American DJ® technician. Replace with anything other than the specified part can damage your unit and will void your manufactures warranty.

**Warning:** If after you have replaced the lamp or reset the breaker and you continue to blow either one, STOP using the unit. Contact customer support for further instructions, you may have to return the unit for servicing. Continuing to use the unit may cause serious damage.

**Breaker Reset:** This unit is equipped with a built-in safety breaker. This breaker is designed to close the power circuit in the event of an internal short or power surge. This will reduce the risk of electrical shock or fire and protect the circuitry. To reset the breaker, push the breaker button in until you hear it "pop" back in to place. If the breaker continues to pop, stop using the unit and contact our customer support team, the unit may need to be returned for service.

**Lamp Replacement:** Caution! Never open the unit when in use. Always disconnect the main power and allow the fixture ample time to cool before attempting to replace the lamp. Lamp replacement has been made simple by incorporating a split dome that is retained by thumb screws. *Again, please remember to always replace with the exact same type lamp.*

1. Be sure to follow the proper procedures when handling halogen lamps. **Never touch the new lamp with your bare fingers.**
2. Unscrew the single thumb screw located on the bottom of the unit. **You do not have to remove the four phillips screws, they secure the fan in place.**
3. Once the thumb screw has been removed, pull the lamp assembly cover plate up to expose the lamp. The fan is attached to the cover plate.
4. Remove and replace the lamp with an exact match.
5. Reassemble in reverse order.

**Fixture Cleaning:**

Due to fog residue, smoke, and dust cleaning the internal and external lenses should be carried out periodically to optimize light output.

1. Use normal glass cleaner and a soft cloth to wipe down the outside casing.
2. Clean the external optics with glass cleaner and a soft cloth every 20 days.
4. Clean the internal optics with glass cleaner and a soft cloth every 30-60 days.
5. Always be sure to dry all parts completely before plugging the unit back in.

Cleaning frequency depends on the environment in which the fixture operates (i.e. smoke, fog residue, dust, dew). In heavy use we recommend cleaning on a monthly basis. Periodic cleaning will ensure longevity, and crisp beam output.

**Trouble Shooting:**

Listed below are a few common problems and solutions you should try before contacting customer support.

**Unit rotates but has no light output from the unit;**

1. Be sure you have connected your unit into a matching wall outlet.
2. Remove the lamp cover and be sure the lamp is seated in its socket properly. Occasionally lamps become loose during shipping be sure the lamp is push in to its socket all the way.
3. Be sure the lamp is good.

**Unit does not rotate and lamp does not turn on;**

1. Be sure you have connected your unit into a matching wall outlet.
2. Be sure the external breaker has not blown. The breaker is located on the rear panel of the unit.
3. Be sure the unit power cord is properly seated in the power outlet and the outlet has power.
4. Be sure the breaker holder is securely seated in the breaker holder housing.

**1 YEAR LIMITED WARRANTY**

A. American DJ® hereby warrants, to the original purchaser, American DJ® products to be free of manufacturing defects in material and workmanship for a period of one Year (365 days) from the date of purchase. This warranty shall be valid only if the product is purchased within the United States of America, including possessions and territories. It is the owner's responsibility to establish the date and place of purchase by acceptable evidence, at the time service is sought.

B. For warranty service, send the product only to the American DJ® factory. All shipping charges must be pre-paid. If the requested repairs or service (including parts replacement) are within the terms of this warranty, American DJ® will pay return shipping charges only to a designated point within the United States. If the entire instrument is sent, it must be shipped in its original package. No accessories should be shipped with the product. If any accessories are shipped with the product, American DJ® shall have no liability whatsoever for loss of or damage to any such accessories, nor for the safe return thereof.

C. This warranty is void if the serial number has been altered or removed; if the product is modified in any manner which American DJ® concludes, after inspection, affects the reliability of the product; if the product has been repaired or serviced by anyone other than the American DJ® factory unless prior written authorization was issued to purchaser by American DJ®; if the product is damaged because not properly maintained as set forth in the instruction manual.

D. This is not a service contract, and this warranty does not include maintenance, cleaning or periodic check-up. During the period specified above, American DJ® will replace defective parts at its expense, and will absorb all expenses for warranty service and repair labor by reason of defects in material or workmanship. The sole responsibility of American DJ® under this warranty shall be limited to the repair of the product, or replacement thereof, including parts, at the sole discretion of American DJ®. All products covered by this warranty were manufactured after January 1, 1990, and bear identifying marks to that effect.

E. American DJ® reserves the right to make changes in design and/or improvements upon its products without any obligation to include these changes in any products theretofore manufactured.

F. No warranty, whether expressed or implied, is given or made with respect to any accessory supplied with products described above. Except to the extent prohibited by applicable law, all implied warranties made by American DJ® in connection with this product, including warranties of merchantability or fitness, are limited in duration to the warranty period set forth above. And no warranties, whether expressed or implied, including warranties of merchantability or fitness, shall apply to this product after said period has expired. The consumer's and or Dealer's sole remedy shall be such repair or replacement as is expressly provided above; and under no circumstances shall American DJ® be liable for any loss or damage, direct or consequential, arising out of the use of, or inability to use, this product.

G. This warranty is the only written warranty applicable to American DJ® Products and supersedes all prior warranties and written descriptions of warranty terms and conditions heretofore published.

H. Lamps are not covered under this or any other warranty either written or implied.

**Technical Specifications:****Model: Whirl 250™**

|                     |   |
|---------------------|---|
| <b>Voltage:</b>     | 120v~60Hz                                   |
| <b>Lamp:</b>        | ZB-ELC 24v/250w                             |
| <b>Breaker:</b>     | 5 Amp                                       |
| <b>Dimensions:</b>  | 14.75" H x 5.5" W x 7.25" D                 |
| <b>Colors:</b>      | Multi-Colored Mirror                        |
| <b>Gobos:</b>       | 1 Interchangeable (26mm -<br>20mm viewable) |
| <b>Weight:</b>      | 6 Lbs.                                      |
| <b>Duty Cycle:</b>  | None  |
| <b>Ventilation:</b> | Fan Cooled                                  |
| <b>Warranty:</b>    | 1 Year (365 Days)                           |

**Please Note:** Specifications and improvements in the design of this unit and this manual are subject to change without any prior written notice.

©American DJ®

American DJ World Headquarters:  
4295 Charter Street Los Angeles, CA 90058 USA

Tel: 323-582-2650 / Fax: 323-582-2610

Web: [www.americandj.com](http://www.americandj.com) / E-mail: [info@americandj.com](mailto:info@americandj.com)