

# Bubble King™

## User Manual

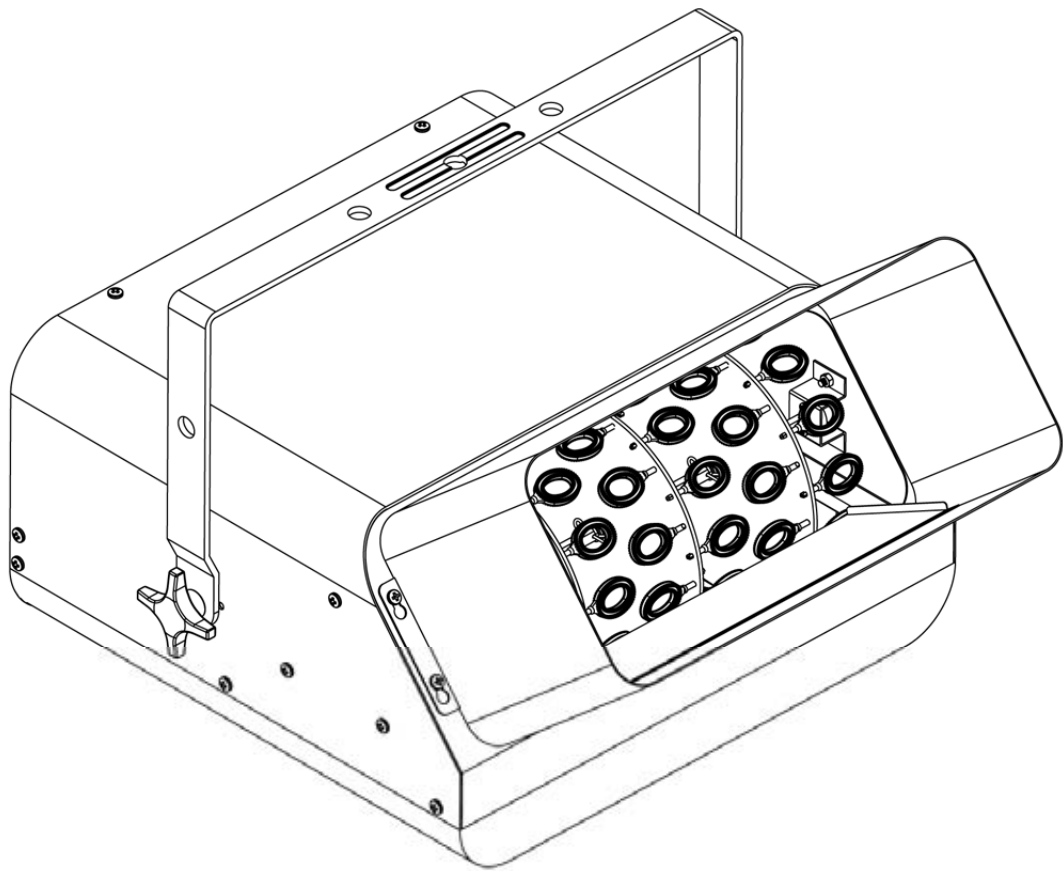

**CHAUVET**®  
Value • Innovation • Performance

---

# TABLE OF CONTENTS

<b>1. Before You Begin</b> .....	<b>3</b>
What Is Included .....	3
Unpacking Instructions.....	3
Claims .....	3
Text Conventions .....	3
Icons.....	3
Document Information.....	3
Product at a Glance .....	4
Safety Notes.....	4
<b>2. Introduction</b> .....	<b>5</b>
Product Overview.....	5
<b>3. Setup</b> .....	<b>6</b>
AC Power .....	6
Fuse Replacement.....	6
Mounting .....	7
Orientation .....	7
Rigging.....	7
<b>4. Operation</b> .....	<b>8</b>
Operation .....	8
<b>5. Technical Information</b> .....	<b>9</b>
Product Maintenance .....	9
General Troubleshooting .....	9
Contact Procedure .....	10
CHAUVET® Contact Information.....	10
Returning Products to CHAUVET® .....	10
<b>6. Technical Specifications</b> .....	<b>11</b>

# 1. BEFORE YOU BEGIN

## What Is Included

- 1 x Bubble King™
- 1 x Power Cord
- 1 x Warranty Card
- 1 x Quick Reference Guide

## Unpacking Instructions

Immediately upon receipt, carefully unpack the product and check the container to make sure you have received all the parts indicated above in good condition.

## Claims



If the container or the material inside the container (the product and included accessories) appear damaged from shipping, or show signs of mishandling, notify the carrier immediately, not CHAUVET®, upon receipt. Failure to do so in a timely manner may invalidate your claim with the carrier. In addition, keep the container and all the packing material for inspection.

For other issues such as missing components or parts, damage not related to shipping, or concealed damage, file a claim with CHAUVET® within seven (7) days of receiving the merchandise.

## Text Conventions

Convention	Meaning
1~512	A range of values
50/60	A set of values of which only one can be chosen
<b>Settings</b>	A menu option not to be modified
<b>Menu &gt; Settings</b>	A sequence of menu options to be followed
<b>&lt;ENTER&gt;</b>	A key to be pressed on the product's control panel
<b>ON</b>	A value to be entered or selected

## Icons

Icon	Meaning
	This paragraph contains critical installation, configuration, or operation information. Failure to comply with this information may render the product partially or completely inoperative, cause damage to the product, or cause harm to the user.
	This paragraph contains important installation or configuration information. Failure to comply with this information may prevent the product from functioning correctly.
	This paragraph reminds you of useful, although not critical, information.

## Document Information

The information and specifications contained in this document are subject to change without notice. CHAUVET® assumes no responsibility or liability for any errors or omissions that may appear in this manual. CHAUVET® reserves the right to update the existing document or to create a new document to correct any errors or omissions.

You can download the latest version of this document from [www.chauvetlighting.com](http://www.chauvetlighting.com).

© Copyright 2011 CHAUVET®. All rights reserved

Electronically published by CHAUVET® in the United States of America

Author	Date	Editor	Date
A. Diaz	10/26/11	B. Pillow	10/27/11

## Product at a Glance

Use on Dimmer	⊘	Auto Programs	⊘
Outdoor Use	⊘	Fixed voltage (120 V or 230 V)	✓
Sound Activated	⊘	Replaceable Fuse	✓
DMX	⊘	User Serviceable	⊘
Master/Slave	⊘	Duty Cycle	⊘

## Safety Notes

Please read the following Safety Notes carefully before working with the product. The Notes include important safety information about installation, usage, and maintenance.



- Always connect the product to a grounded circuit to avoid the risk of electrocution.
- Always disconnect the product from the power source before cleaning or replacing the fuse.
- Make sure the power cord is not crimped or damaged.
- Never disconnect the product from power cord by pulling or tugging on the cord.
- If mounting the product overhead, always secure to a fastening device using a safety cable.
- Make sure there are no flammable materials close to the product when operating.



- Always make sure that the voltage of the outlet to which you are connecting the product is within the range stated on the decal or rear panel of the product.
- The product is for indoor use only! (IP20) To prevent risk of fire or shock, do not expose the product to rain or moisture.
- Always install the product in a location with adequate ventilation, at least 20 in (50 cm) from adjacent surfaces.
- Be sure that no ventilation slots on the product's housing are blocked.
- Never connect the product to a dimmer.
- Make sure to replace the fuse with another of the same type and rating.
- Never carry the product from the power cord or any moving part. Always use the hanging/mounting bracket or the handles.
- The maximum ambient temperature is 104° F (40° C). Do not operate the product at higher temperatures.
- **Do not leave unused fluid in the reservoir for an extended period. The fluid may thicken in the reservoir.**
- In the event of a serious operating problem, stop using the product immediately.
- Never try to repair the product. Repairs carried out by unskilled people can lead to damage or malfunction. Please contact the nearest authorized technical assistance center.



- Keep this User Manual for future consultation. If you sell the product to another user, be sure that they also receive this document.

---

# 2. INTRODUCTION

## Product Overview

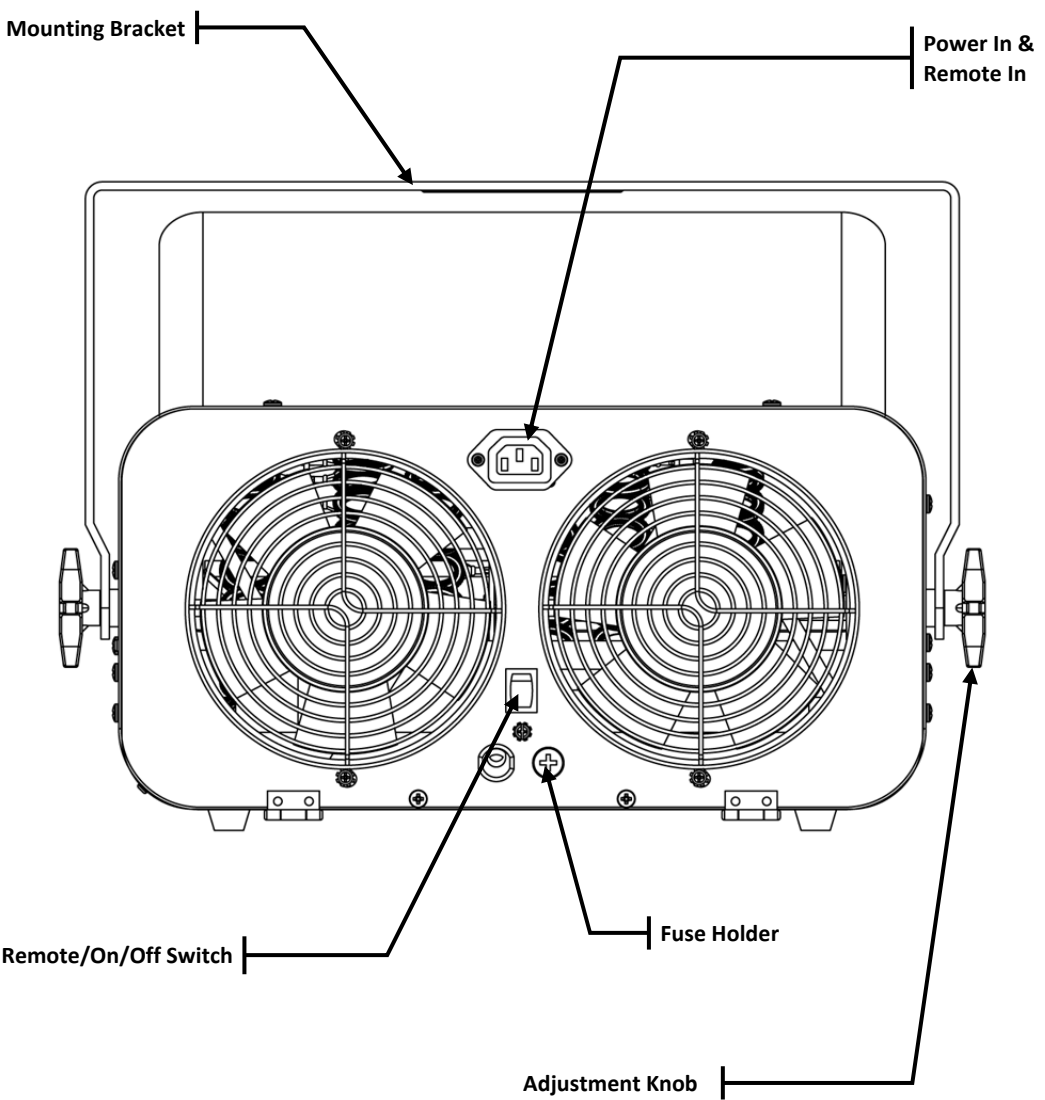

---

## 3. SETUP

**AC Power** The Bubble King™ has a fixed voltage power supply and can work with an input voltage of either 120 V, 60 Hz or 230 V, 50 Hz, depending on the specific model.

To determine the product's power requirements (circuit breaker, power outlet, and wiring), use the current value listed on the label affixed to the product's back panel, or refer to the product's specifications chart. The listed current rating indicates the product's average current draw under normal conditions.



**Always connect the product to a protected circuit (circuit breaker or fuse). Make sure the product has an appropriate electrical ground to avoid the risk of electrocution or fire.**



**Never connect the product to a rheostat (variable resistor) or dimmer circuit, even if the rheostat or dimmer channel serves only as a 0 to 100% switch.**

### Fuse Replacement

Follow the instructions below to change the fuse, if necessary.



**Disconnect the product from the power outlet before replacing the fuse.**

1. Disconnect the product from the power outlet.
2. With a Phillips #2 head screwdriver, unscrew the fuse holder cap from the housing.
3. Remove the blown fuse and replace with a good fuse of the same type and rating.
4. Screw the fuse holder cap back in place and reconnect power.



**Always replace a blown fuse with the same type and rating.**

---

**Mounting** Before mounting the product, read and follow the safety recommendations indicated in the *Safety Notes* section.

**Orientation** The Bubble King™ may be mounted in any position; however, make sure adequate ventilation is provided around the product.

- Rigging**
- Before deciding on a location for the product, always make sure there is easy access to the product for maintenance and fluid replenishment purposes.
  - Make sure that the structure or surface onto which you are mounting the product can support the product's weight. Please see the *Technical Specifications* section of this manual for weight information.
  - When mounting the product overhead, always use a safety cable. Mount the product securely to a rigging point, whether an elevated platform or a truss.
  - When rigging the product onto a truss, you should use a mounting clamp of appropriate weight capacity. The bracket has a 13 mm hole, which is appropriate for this purpose.
  - The bracket adjustment knobs allow for directional adjustment when aiming the product to the desired angle. Only loosen or tighten the bracket knobs manually. Using tools could damage the knobs.

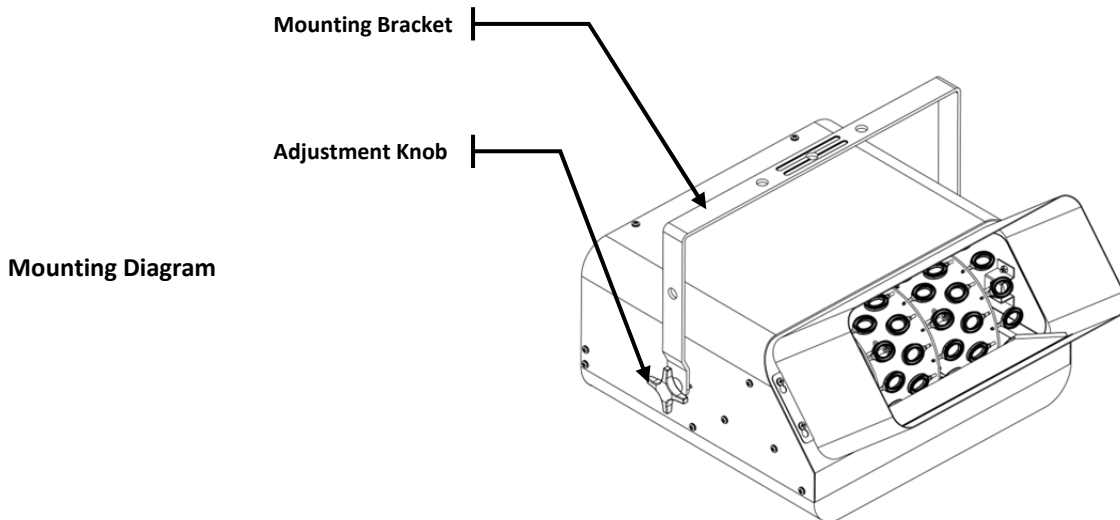

---

## 4. OPERATION

- Operation**
1. Place the Bubble King™ on a level surface and loosen the thumbscrews on the front of the unit for fluid tank access. Lift the cover.
  2. Fill the tank with bubble fluid.  
**Note: We recommend using CHAUVET® bubble fluid (BJU) which has been specially formulated for use with CHAUVET® Bubble Kings.**
  3. Lower the cover and tighten screws.
  4. Plug into a suitable wall outlet.
  5. Turn on the unit. For remote use, move the switch to Remote and use the optional remote controller to operate the Bubble King™.  
**Note: Do not leave unused fluid in the reservoir for an extended period. The fluid may thicken in the reservoir.**

**AC-W wireless controller** is now available for use with the Bubble King™. The AC-W is a wireless trigger that does not need an external power supply — easy setup and easy teardown.

In addition, the AC-W has an operation range of 100 ft (unobstructed) for increased flexibility enabling the attached machines to be triggered from almost anywhere.

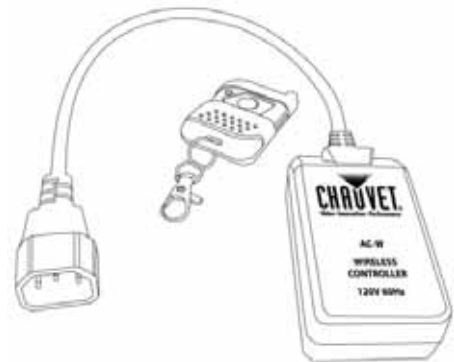



# 5. TECHNICAL INFORMATION

## Product Maintenance

Dust build up reduces output performance and can cause overheating. This can lead to reduction of the product's life and mechanical wear. To maintain optimum performance and minimize wear, you should clean your products frequently. However, be aware that usage and environmental conditions could be contributing factors to increase the cleaning frequency.

After every 40 hours of continuous operation or when the machine will be idle for a long time it is recommended to rinse the bubble wands and fluid tank with warm water to prevent a build-up of residue which could reduce performance.

To clean the product, follow the instructions below:

- While the unit is unplugged, loosen the thumbscrew and lift cover to reveal the fluid tank.
- Empty all bubble fluid from the tank and replace with warm water.
- Plug the product in and allow it to run as usual until all wands appear to be free of residue.



**Always dry the surfaces carefully after cleaning them.**



**Do not spin the fan using compressed air because you could damage it.**

## General Troubleshooting

Symptom	Possible Cause	Possible Action
Circuit breaker or fuse keeps blowing	• Excessive load on the circuit	• Make sure that the total load does not exceed 80% of the breaker or fuse nominal current
	• Short circuit along the power lines	• Check the power lines and power cords
Product does not power up	• No energy on power outlet	• Check power outlet • Change to another outlet
	• Loose or damaged power cord	• Check the power cord
	• Blown fuse	• Replace blown fuse with a good one of the same type and rating
	• Internal problem	• Send product for repair



**If you still experience problems after trying the above solutions, contact CHAUVET® Technical Support.**

## Contact Procedure

In case you need to return a product or request support, follow the procedure below:

- If you live in the US, contact CHAUVET® World Headquarters (see below).
- If you live in the UK or Ireland, contact CHAUVET® Europe Ltd.(see below).
- If you live in any other country, DO NOT contact CHAUVET®. Instead, contact your distributor of record. Refer to our Web site for contact details of distributors outside the US, United Kingdom, or Ireland.

## CHAUVET® Contact Information

### World Headquarters

CHAUVET®

#### General Information

Address: 5200 NW 108th Avenue  
Sunrise, FL 33351  
Voice: (954) 929-1115  
Fax: (954) 929-5560  
Toll free: (800) 762-1084

#### Technical Support

Voice: (954) 929-1115 (Press 4)  
Fax: (954) 756-8015  
Email: tech@chauvetlighting.com

#### World Wide Web

[www.chauvetlighting.com](http://www.chauvetlighting.com)

### United Kingdom & Ireland

CHAUVET® Europe Ltd.

#### General Information

Address: Unit 1C  
Brookhill Road Industrial Estate  
Pinxton, Nottingham, UK  
NG16 6NT  
Voice: +44 (0)1773 511115  
Fax: +44 (0)1773 511110

#### Technical Support

Email: [uktech@chauvetlighting.com](mailto:uktech@chauvetlighting.com)

#### World Wide Web

[www.chauvetlighting.co.uk](http://www.chauvetlighting.co.uk)



**If you live outside the US, United Kingdom, or Ireland, contact your distributor of record and follow their instructions on how to return CHAUVET® products to them. Visit our Web site for contact details.**

## Returning Products to CHAUVET®

Call the corresponding CHAUVET® Tech Support office and request a Return Merchandise Authorization (RMA) number before shipping the product. Be prepared to provide the model number, serial number, and a brief description of the cause for the return.

You must send the merchandise prepaid, in its original box, and with its original packing and accessories. CHAUVET® will not issue call tags.

Clearly label the package with the RMA number. CHAUVET® will refuse any product returned without an RMA number.



**Write the RMA number on a properly affixed label. DO NOT write the RMA number directly on the box.**

Before sending the product, clearly write the following information on a piece of paper and place it inside the box:

- Your name
- Your address
- Your phone number
- The RMA number
- A brief description of the problem

Be sure to pack the product properly. Any shipping damage resulting from inadequate packaging will be your responsibility. As a suggestion, proper UPS packing or double-boxing is always a safe method to use.



**CHAUVET® reserves the right to use its own discretion to repair or replace returned product(s).**

## 6. TECHNICAL SPECIFICATIONS

<b>Dimensions and Weight</b>	<b>Length</b>	<b>Width</b>	<b>Height</b>	<b>Weight</b>
	19 in (483 mm)	15 in (381 mm)	12 in (305 mm)	13.2 lbs (5.9 kg)

**Note:** Dimensions in inches rounded to the nearest decimal digit.

<b>Power</b>	<b>Power Supply Type</b>	<b>Range</b>	<b>Voltage Selection</b>
	Voltage specific	115 V, 60 Hz or 230 V, 50 Hz	Fixed voltage

	<b>Parameter</b>	<b>120 V, 60 Hz</b>	<b>230 V, 50 Hz</b>
	Consumption	58 W	84 W
	Operating / Inrush current	1.2 A / 1.2 A	0.4 A / 0.5 A
	Fuse	F 1 A, 250 V	F 1 A, 250 V

	<b>Power I/O</b>	<b>US/Worldwide</b>	<b>UK/Europe</b>
	Power Cord plug	Edison (US)	Local plug

<b>Thermal</b>	<b>Maximum External Temp.</b>
	104° F (40° C)

<b>Ordering</b>	<b>Product Name</b>	<b>Item Code</b>	<b>Item Number</b>
	Bubble King	02070055	B-550