

COLORdash™ Par

Snapshot

OK on Dimmer	⊘
Outdoor OK	⊘
Sound Activated	⊘
DMX512	✓
Master/Slave	✓
Autoswitching Transformer	✓
Replaceable Fuse	✓
User Serviceable	⊘
Duty Cycle	⊘

USER MANUAL

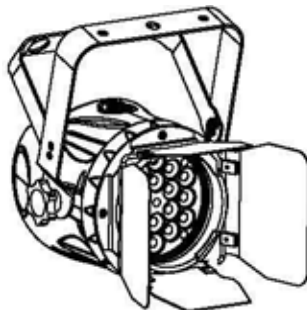

Chauvet, 3000 N 29th Ct, Hollywood, FL 33020 U.S.A.
(800) 762-1084 – (954) 929-1115
FAX (954) 929-5560
www.chauvetlighting.com

TABLE OF CONTENTS

1. Before You Begin	3
What is included.....	3
Unpacking Instructions	3
Safety Instructions	4
LED Expected Lifespan	4
2. Introduction	5
Features	5
DMX Channel Summary	6
Product Overview.....	7
3. Setup	8
AC Power	8
Mounting.....	9
Orientation.....	9
Rigging	9
Lens Assembly Installation/Replacement	10
Fixture Linking.....	11
Data Cabling	11
DMX Data Cable	11
Cable Connectors	11
3-Pin to 5-Pin Conversion Chart.....	12
Setting up a DMX Serial Data Link.....	12
Master/Slave Fixture Linking	12
4. Operating Instructions	13
Control Options	13
DMX-512 control without "ID" address	13
DMX-512 addressing with ID address.....	13
COLORcon™ Setup	14
Setting the DMX address.....	15
Control Panel Functions	15
Password Menu Lockout	15
Upload Customs.....	16
Menu Map	16
DMX512 Channel Values	18
Important Notes about STAGE 1 DMX Operation	20
5. COLORado™ Controller	21
Overview	21
Setup	21
Menu Map	22
Wash Program	22
Effect Program	22
Custom Program.....	23
Play Schedule	23
Clock.....	23
Schedule	23
Settings.....	23
Activating password mode.....	24
Control via external DMX.....	24
Technical Support	25
Contact Us.....	25
6. Appendix	26
DMX Primer	26
General Maintenance	27
Returns Procedure	27
Claims.....	27
Photometrics	28
Mini Par Service Maintenance Guide.....	29
Blow-out Diagram.	30
Technical Specifications	32

1. BEFORE YOU BEGIN

What is included

- 1 x COLORdash™ Par
- 1 x Power cable with plug
- 1 x 6.6ft (2m) power linking cable
- 1 x set of replacement screws for barn doors removal
- 1 x Warranty Card
- 1 x User Manual

Unpacking Instructions

Immediately upon receiving a fixture, carefully unpack the carton, check the contents to ensure that all parts are present, and have been received in good condition. Notify the shipper immediately and retain packing material for inspection if any parts appear damaged from shipping or the carton itself shows signs of mishandling. Save the carton and all packing materials. In the event that a fixture must be returned to the factory, it is important that the fixture be returned in the original factory box and packing.

Safety Instructions



Please read these instructions carefully, which includes important information about the installation, usage and maintenance of this product.

- Please keep this User Guide for future consultation. If you sell the unit to another user, be sure that they also receive this instruction booklet.
- Always make sure that you are connecting to the proper voltage, and that the line voltage you are connecting to is not higher than that stated on the decal or rear panel of the fixture.
- The unit must be installed in a location with adequate ventilation, at least 20in (50cm) from adjacent surfaces. Be sure that no ventilation slots are blocked.
- Always disconnect from power source before servicing or replacing lamp or fuse and be sure to replace with same lamp source.
- Secure fixture to fastening device using a safety chain. Never carry the fixture solely by its head. Use its carrying handles.
- Maximum ambient temperature (Ta) is 104°F (40°C). Do not operate fixture at temperatures higher than this.
- In the event of a serious operating problem, stop using the unit immediately. Never try to repair the unit by yourself. Repairs carried out by unskilled people can lead to damage or malfunction. Please contact the nearest authorized technical assistance center. Always use the same type spare parts.
- Never connect the device to a dimmer pack.
- Make sure the power cord is never crimped or damaged.
- Never disconnect the power cord by pulling or tugging on the cord.
- Avoid direct eye exposure to the light source while it is on.
- Do not daisy chain power to more than 25 units @ 120volts.

Caution! *There are no user serviceable parts inside the unit. Do not open the housing or attempt any repairs yourself. In the unlikely event your unit may require service, please contact CHAUVET at: 954-929-1115.*

Note! *Power linking may not be available for 230V versions*

Caution! *After prolonged periods of operation, the fixture chassis may reach high temperatures. Use caution when handling this fixture.*

LED Expected Lifespan

LEDs gradually decline in brightness over time. HEAT is the dominant factor that leads to the acceleration of this decline. Packaged in clusters, LEDs exhibit higher operating temperatures than in ideal or singular optimum conditions. For this reason when all color LEDs are used at their fullest intensity, life of the LEDs is significantly reduced. It is estimated that a viable lifespan of 40,000 to 50,000 hours will be achieved under normal operational conditions. If improving on this lifespan expectancy is of a higher priority, place care in providing for lower operational temperatures. This may include climatic-environmental and the reduction of overall projection intensity

2. INTRODUCTION

Features

- 3, 4 or 9-channel DMX-512 LED wash light (with ID addressing)
- Operating modes
 - 3-channel: RGB control
 - 4-channel: RGB, dimmer
 - 9-channel: RGB, ID, dim, macro, strobe, automatic, custom
- Blackout/static/dimmer/strobe/pulse
- RGB color mixing with or without DMX controller
- Built-in automated programs via master/slave, DMX or COLOR-CON
- Recall custom programs via master/slave or DMX

ADDITIONAL FEATURES

- High-power, 1W (350mA) LEDs
- Additional (IEC) power output: max 25 units @ 120V (see manual for details)
- LCD display with password protection
- Adjustable barn doors to direct output
- Transfer custom programs between fixtures
- Double-bracket yoke doubles as floor stand

OPTIONS

- COLORado Controller (COLOR-CON)
- Optical systems: 15° (installed), 30° (CL20X30)
- 33ft (10m) power extension cable (EXT-2)

DMX Channel Summary

The COLORdash™ Par has a total of 3 DMX channel configurations, referred to as “Personalities” in this manual and in the fixture onboard control board. The 3 personalities are [STAGE 1, ARC1, ARC1+D]. Each of the different personalities can be accessed from the control panel. Please see section on “Control Panel Functions” on a description on how to accomplish this.

[STAGE 1]	CHANNEL	DESCRIPTION
	1	Dimmer
	2	Red
	3	Green
	4	Blue
	5	Color Macro
	6	Strobe
	7	Auto & Custom Programs
	8	Auto Speed Adjustment
	9	ID Address Selection

[ARC 1]	CHANNEL	DESCRIPTION
	1	Red
	2	Green
	3	Blue

[ARC1+D]	CHANNEL	DESCRIPTION
	1	Dimmer
	2	Red
	3	Green
	4	Blue

Product Overview

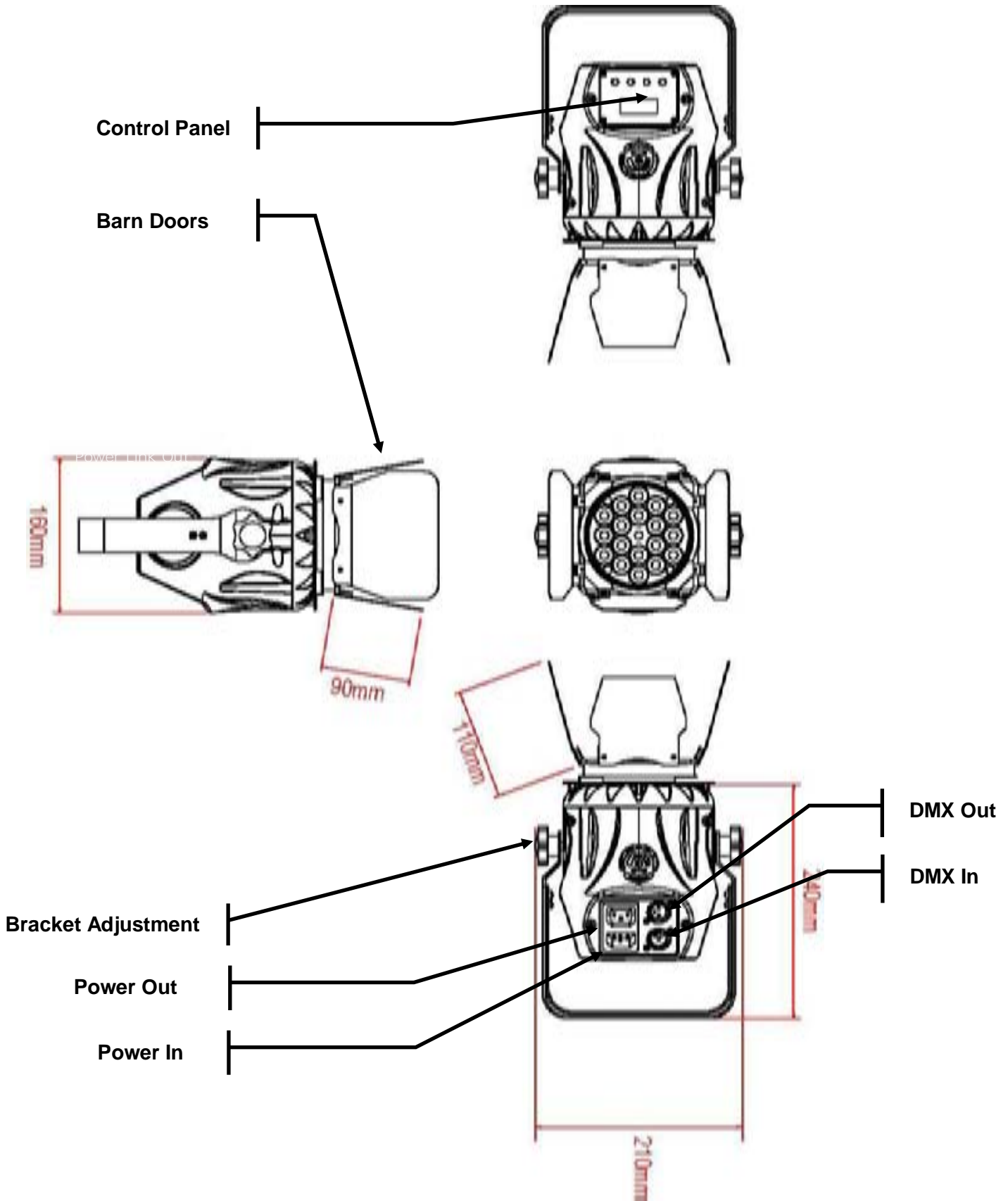

3. SETUP

AC Power

This fixture has an auto-switching power supply that can accommodate a wide range of input voltages. The only thing necessary to do before powering on the unit is to make sure the line voltage you are applying is within the range of accepted voltages. This fixture will accommodate between 100V and 240V AC 50-60 Hz. All fixtures must be powered directly off a switched circuit and cannot be run off a rheostat (variable resistor) or dimmer circuit, even if the rheostat or dimmer channel is used solely for a 0% to 100% switch.

This fixture is designed for power linking from one COLORdash™ PAR to another COLORdash™ PAR fixture.

Warning! *All fixtures must be connected to circuits with a suitable Earth Ground.*

Depending on the application, the lighting fixture may require a different connector. Please refer to the below wire color code if installing a new connector.

Wire	Connection
Brown	AC Live
Blue	AC Neutral
Green/Yellow	AC Ground

Connection	Pin
AC Live	1
AC Neutral	2
Ground(Earth)	3

Mounting

Orientation

This fixture may be mounted in any safe position.

Rigging

The fixture includes a mounting yoke to which a rigging clamp can be attached. You must supply your own clamp and make sure the clamp is capable of supporting the weight of this fixture. You can order “C” and “O”-clamps from any CHAUVET dealer or distributor (CLP-15, CLP-06 recommended).

Note: There are 2 types of applications for this fixture: floor stand for up lighting, and overhead use for down lighting. If you are using this fixture for up lighting, then you must use at least 1 safety cable/chain for each fixture in addition to the mounting brackets.

If hanging the fixture for over head use, then please follow the below steps.

1. Block access below the work area and use suitable and stable platform when installing or servicing fixture.
2. Safety cables must always be used, secured through the heat sink ventilation passageway. The safety cable must be capable of holding 10 times the weight of the fixture.
3. Verify the structure can hold 10 times the weight of all to-be installed fixtures.

Caution!

After prolonged periods of operation, the fixture chassis may reach high temperatures. This fixture must be mounted in a ventilated location, as it uses forced convection cooled.

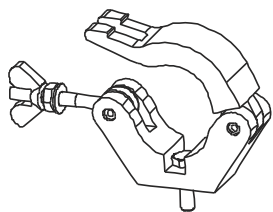

Hanging Clamp
Note: sold separately

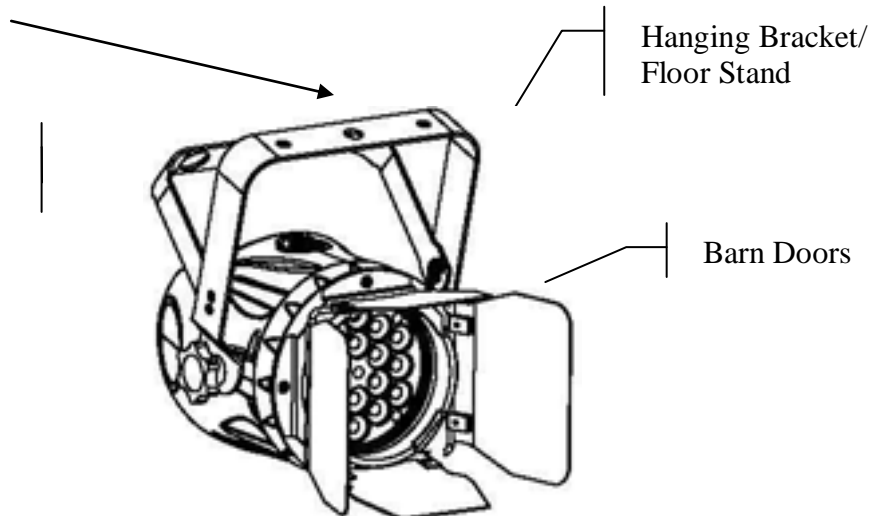

Lens Assembly Installation/Replacement

The LED-SPLASH™3 comes with 15° lens assembly pre-installed from the factory. However, there are 2 other optional lens kits (**CL20X10**, **CL20X30**) available as accessories, which will alter the beam angle. Please follow the below instructions for proper replacement/installation.

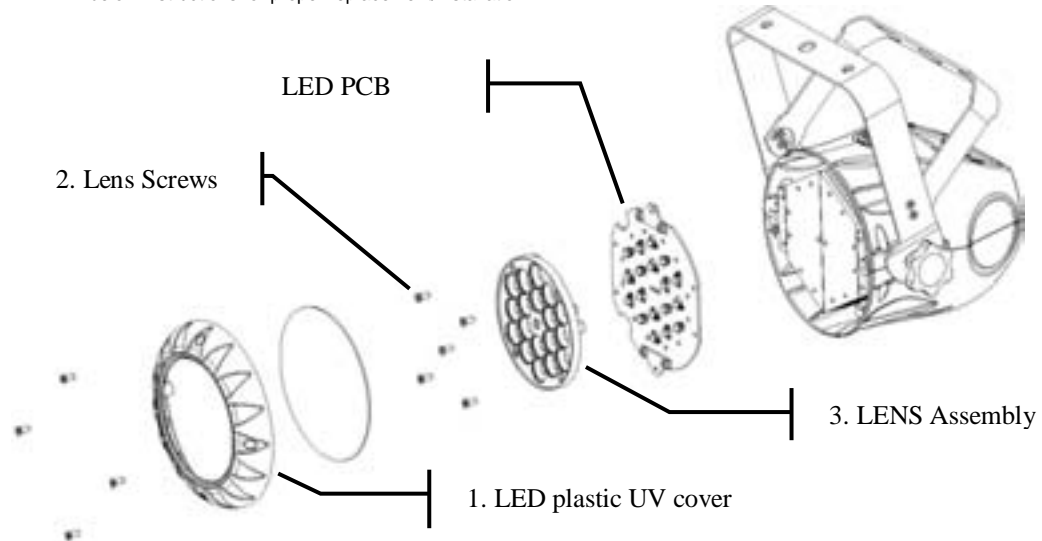

1. Remove the front, plastic UV cover (black) by removing the screws that hold it in place. There are 4 screws to remove for this step.
2. After removing the glass cover, remove the screws that hold the lens assembly in place. There are 5 screws for this step.

Note: use care when performing this procedure, as this gives you direct access to the LEDs, which are very fragile.

3. You now should have full access to the lens assembly. This must be removed and the old lenses must be replaced with the new lenses. The same assembly is to be reinstalled with the new lenses in place and the process is complete.

Warning!

1. **When replacing the lens assembly, please make sure that the power is disconnected from the fixture beforehand.**

Fixture Linking

You will need a serial data link to run light shows of one or more fixtures using a DMX-512 controller or to run synchronized shows on two or more fixtures set to a master/slave operating mode. The combined number of channels required by all the fixtures on a serial data link determines the number of fixtures the data link can support.

Important: Fixtures on a serial data link must be daisy chained in one single line. To comply with the EIA-485 standard no more than 32 devices should be connected on one data link. Connecting more than 32 fixtures on one serial data link without the use of a DMX optically-isolated splitter may result in deterioration of the digital DMX signal.

Maximum recommended serial data link distance: 500 meters (1640 ft.)

Maximum recommended number of fixtures on a serial data link: 32 fixtures

Data Cabling

To link fixtures together you must obtain data cables. You can purchase CHAUVET-certified DMX cables directly from a dealer/distributor or construct your own cable. If you choose to create your own cable please use data-grade cables that can carry a high quality signal and are less prone to electromagnetic interference.

DMX DATA CABLE

Use a Belden® 9841 or equivalent cable which meets the specifications for EIA RS-485 applications. Standard microphone cables cannot transmit DMX data reliably over long distances. The cable will have the following characteristics:

*2-conductor twisted pair plus a shield
Maximum capacitance between conductors – 30 pF/ft.
Maximum capacitance between conductor and shield – 55 pF/ft.
Maximum resistance of 20 ohms / 1000 ft.
Nominal impedance 100 – 140 ohms*

CABLE CONNECTORS

Cabling must have a male XLR connector on one end and a female XLR connector on the other end.

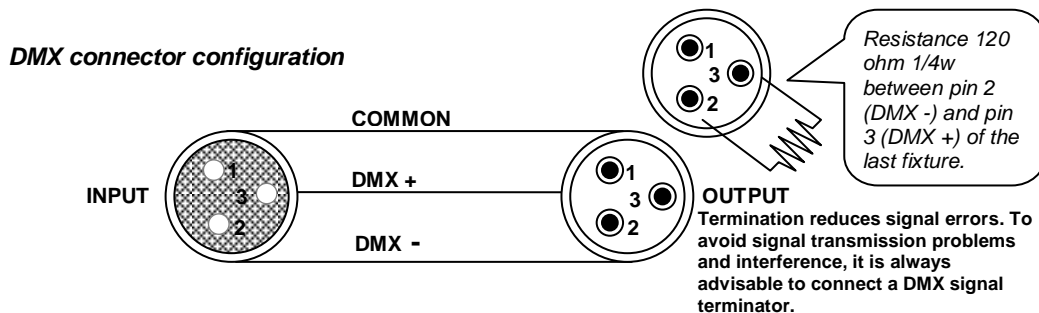

CAUTION Do not allow contact between the common and the fixture's chassis ground. Grounding the common can cause a ground loop, and your fixture may perform erratically. Test cables with an ohm meter to verify correct polarity and to make sure the pins are not grounded or shorted to the shield or each other.

3-PIN TO 5-PIN CONVERSION CHART

Note! If you use a controller with a 5 pin DMX output connector, you will need to use a 5 pin to 3 pin adapter. CHAUVET Model No: DMX5M, or DMX5F. The chart below details a proper cable conversion:

3 PIN TO 5 PIN CONVERSION CHART		
Conductor	3 Pin Female (output)	5 Pin Male (Input)
Ground/Shield	Pin 1	Pin 1
Data (-) signal	Pin 2	Pin 2
Data (+) signal	Pin 3	Pin 3
Do not use		Do not use
Do not use		Do not use

Setting up a DMX Serial Data Link

1. Connect the (male) 3 pin connector side of the DMX cable to the output (female) 3 pin connector of the controller.
2. Connect the end of the cable coming from the controller which will have a (female) 3 pin connector to the input connector of the next fixture consisting of a (male) 3 pin connector.
3. Then, proceed to connect from the output as stated above to the input of the following fixture and so on.

CHAUVET Certified DMX Data Cables

Order Code	Description
DMX1.5	DMX Cable 1.5m/4.9ft
DMX4.5	DMX Cable 4.5m/14.8ft
DMX10	DMX Cable 10m/32.8ft

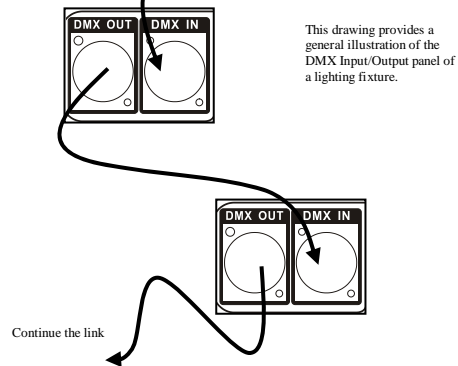
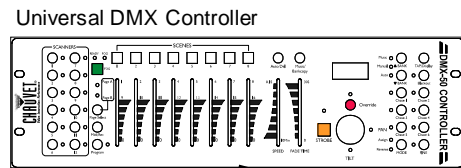

This drawing provides a general illustration of the DMX Input/Output panel of a lighting fixture.

Master/Slave Fixture Linking

1. Connect the (male) 3 pin connector side of the DMX cable to the output (female) 3 pin connector of the first fixture.
2. Connect the end of the cable coming from the first fixture which will have a (female) 3 pin connector to the input connector of the next fixture consisting of a (male) 3 pin connector. Then, proceed to connect from the output as stated above to the input of the following fixture and so on.

Often, the setup for Master-Slave and Standalone operation requires that the first fixture in the chain be initialized for this purpose via either settings in the control panel or DIP-switches. Secondly, the fixtures that follow may also require a slave setting. Please consult the "Operating Instructions" section in this manual for complete instructions for this type of setup and configuration.

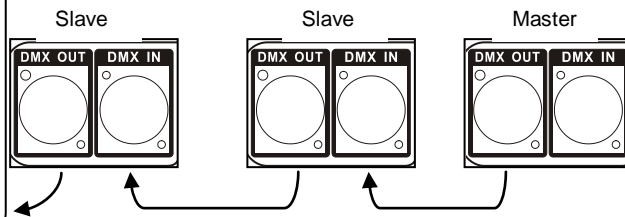

4. OPERATING INSTRUCTIONS

Control Options

The COLORdash™ PAR is addressable in the DMX range of 001 to 512. In its simplest control form, this allows for the control of up to 56 fixtures in the 9-channel Stage1 personality; however, a secondary “ID” address system exists for use in a limited DMX universe and architectural environments. The “ID” address system allows the user to assign up to 66 fixtures within the same DMX address; in effect, multiplying the control of COLORdash™ PAR within a single universe to 3,696 fixtures. The COLORDASH™ PAR “ID” address system is accessed using DMX channel 9 [Stage 1]. Consideration must be placed when programming live performances or cues that need to trigger on demand or on a time line. So, to remain within one second execution time, program no greater than 10 fixtures on ID addressing per DMX channel.

DMX-512 control without “ID” address

The COLORdash™ PAR operates on 9 channels of DMX (“STAGE 1” personality). Address each fixture in increments of 9 channels. (I.e. 1,10,19,28, etc...) To save time you can use the same DMX address for each fixture. All fixtures will then respond simultaneously to control. You may also group your fixtures and address those groups alike for faster programming and control.

1. Access the control panel function by pressing the **(MENU)** button until the **{RUN}** is displayed.
2. Press **(ENTER)** and use the **(UP/DOWN)** buttons to select **{DMX}** function.
3. Then, Press **(MENU)** button until **{ADDRESS}** is displayed.
4. Press the **(ENTER)** button.
6. Use the **(UP/DOWN)** buttons to increase or decrease channels between 001 and 512.
7. Press the **(ENTER)** button to confirm action. Then press **(MENU)** to exit.

Deactivate ID addressing in each fixture by setting panel function **{ID ON/OFF}** to OFF.
{MENU} ⇨ {SETTINGS} ⇨ {ID ON/OFF} ⇨ [OFF]

Notes: If ID addressing is not deactivated in the fixture’s control panel function, unintended results may occur if values are present in channel 9. Make sure values on channel 9 are set to “0”.

DMX-512 addressing with ID address

1. Follow instructions 1 ~ 7 in the previous section for DMX512 addressing.
2. Activate ID addressing in each fixture by setting panel function **{ID ON/OFF}** to ON.
{MENU} ⇨ {Settings} ⇨ {ID ON/OFF} ⇨ [ON]
3. For every DMX512 starting address the user can set 66 separate ID addresses.
4. Set ID addresses in each fixture by setting panel function **{ID address}** to incremental values. (I.e. 1,2,3,4,5,6,etc...)
{MENU} ⇨ {Settings} ⇨ {ID address} ⇨ [01 ~ 66]
5. ID addresses are accessible using Channel 9 [Stage 1].

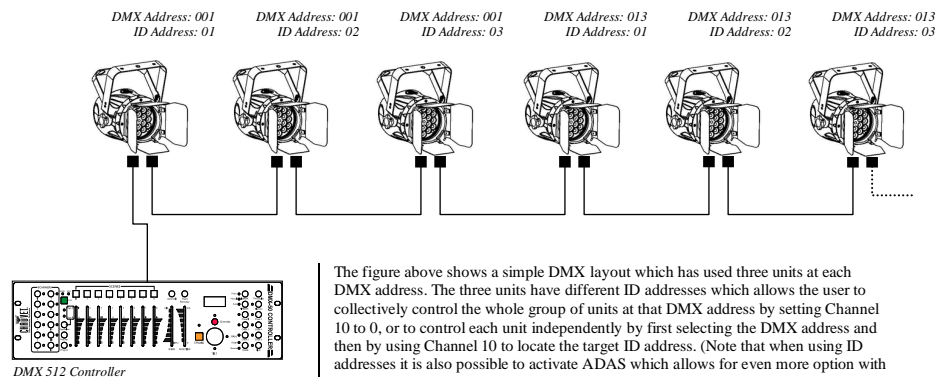

The figure above shows a simple DMX layout which has used three units at each DMX address. The three units have different ID addresses which allows the user to collectively control the whole group of units at that DMX address by setting Channel 10 to 0, or to control each unit independently by first selecting the DMX address and then by using Channel 10 to locate the target ID address. (Note that when using ID addresses it is also possible to activate ADAS which allows for even more option with DMX addressing and control.

COLORcon™ Setup

1. FIXTURE CONTROL PANEL SETUP

Activate ID addressing in each fixture by setting panel function **{ID ON/OFF}** to ON.
{MENU} → **{Settings}** → **{ID ON/OFF}** → **[ON]**

Set ID addresses in each fixture by setting panel function **{ID address}** to incremental values. (I.e. 1,2,3,4,5,6,etc...)

{MENU} → **{Settings}** → **{ID address}** → **[01 ~ 66]**

It is not necessary to set the DMX address.

2. CONTROLLER SETUP

When using the **{Effect program}** function, it is necessary to set the **{Settings}** → **{Range}** setting, which is the quantity of fixtures in series.

{MENU} → **{Settings}** → **{Range}** → **[(No. of fixtures)]**

Single Row Application

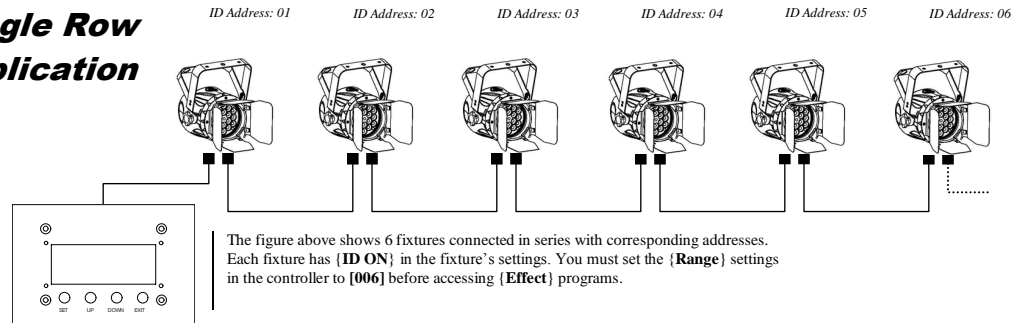

Repeat Row Block Application Block Application

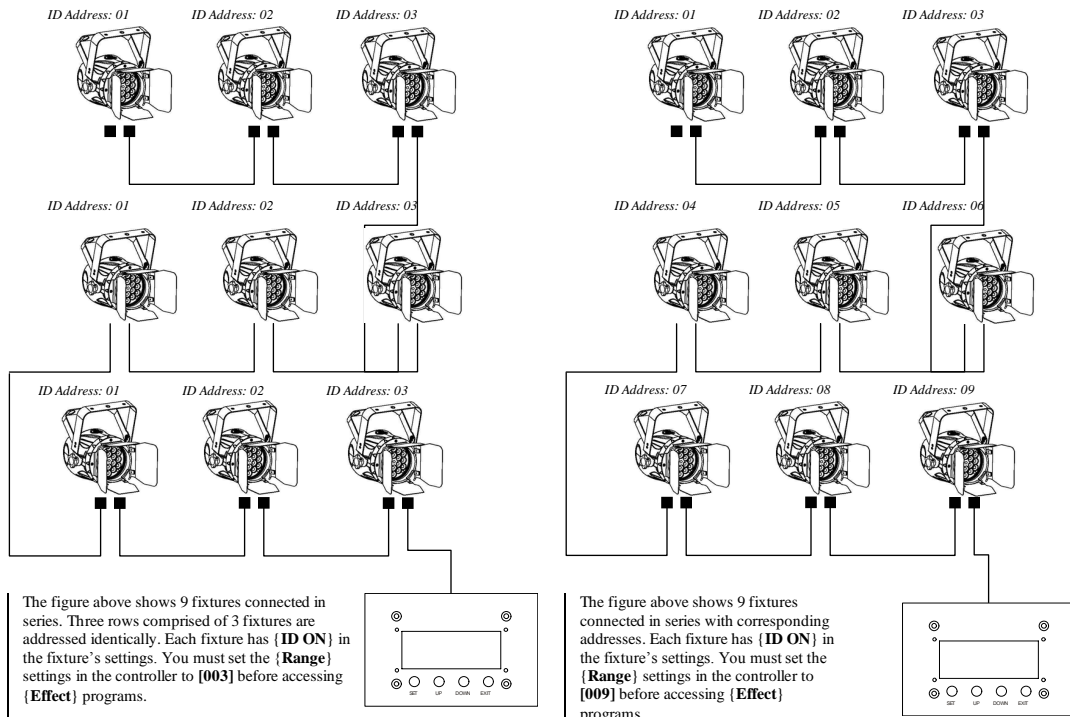

Setting the DMX address

Each fixture requires a "start address" from 1 to 512. A fixture requiring one or more channels for control begins to read the data on the channel indicated by the start address. For example, a fixture that occupies or uses 7 channels of DMX and was addressed to start on DMX channel 100, would read data from channels: 100, 101, 102, 103, 104, 105 and 106. Choose start addresses so that the channels used do not overlap and note the start address selected for future reference. The COLORado™ Panel uses up to 9 channels of DMX. If this is your first time using DMX, we recommend reading the DMX Primer in the Appendix Section.

Control Panel Functions

All fixture functions and settings are accessible via the built-in control panel interface.

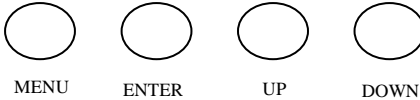

BUTTON	FUNCTION
MENU	Exits from the current menu or function
ENTER	Enables the currently displayed menu or sets the currently selected value in to the selected function
UP	Navigates upwards through the menu list and increases the numeric value when in a function
DOWN	Navigates downwards through the menu list and decreases the numeric value when in a function

Password Menu Lockout

The COLORdash™ PAR has a password lock-out feature. This can be enabled/disabled by using the Control Panel.

- **Note:** This feature uses a default, non-changeable, password of up + down + up + down. After 30 seconds of inactivity, the lockout will automatically engage once it has been enabled.

Upload Customs

The custom programs in the COLORdash™ Par may be transferred (copied) from one fixture to another, thus giving the ability to have to only program them on a single fixture, and then duplicate this only several others. This is referenced in the Control Panel as “Upload”. Follow the below steps for this process. On all fixtures that are going to receive the upload, set them on DMX operation. The address does not matter for this operation.

1. Disconnect from DMX controller
2. Select “Settings” in the Control Board and press Enter.
3. Select “Upload Customs” and press enter.
4. Press enter. The “customs” portion of the screen will begin to flash. Press enter to confirm and begin the transfer.
5. The slave fixtures will display green if the transfer is successful. They will display red if the transfer is unsuccessful.

Note: the units receiving the new custom programs from the master must be set to “SLAVE”. Otherwise, they will not allow receipt of the programs.

Menu Map

MAIN FUNCTION	SUB-FUNCTION	SELECTION	INSTRUCTION
1. Static Color	Red	000 ~ 255* (0 ~ 100%)	User can combine Red, Green and Blue to generate a custom color Select strobing frequency between 0 and 20Hz
	Green		
	Blue	*Strobe range is 0~20	
	Strobe		
2. Auto	Auto	(1~10)	Choose from 10 automatic programs
	Custom	(1~10)	Choose from 10 programs that be customized under the “edit custom” menu option
3. DMX Address		001 ~ 512	Sets the DMX starting address
4. Run		DMX~Slave	Sets the operating mode for the fixture: to receive signal from a DMX controller (DMX) or to receive signal from the DMX out of another fixture
5. Personality		Stage 1	9-channel RGBW+D
		Arc 1	3-channel RGB
		Arc 1+D	4-channel RGB+D
6. ID Address		0-66	Assigns the ID address to a fixture
7. Edit Custom	Custom (1~10)	Red	User can combine Red, Green and Blue to generate a custom color (0~255)
		Green	
	Blue		
	-(Scene 01-30)	Strobe	Select strobing frequency (0 ~20Hz)
		Time	(0~255)
Fade		(0~255)	
8. Settings	ID	On~Off	Turns ID addressing on or off
	Reset to factory?	(Press enter 2 times)	Resets the fixture to the default, factory settings
	Upload custom?	(Press enter 2 times)	Uploads a fixture’s custom program to another fixture (same fixture only)
19. Password		On~Off	Turns the password on or off (after 30s of no action, the password will automatically turn on after selecting On)

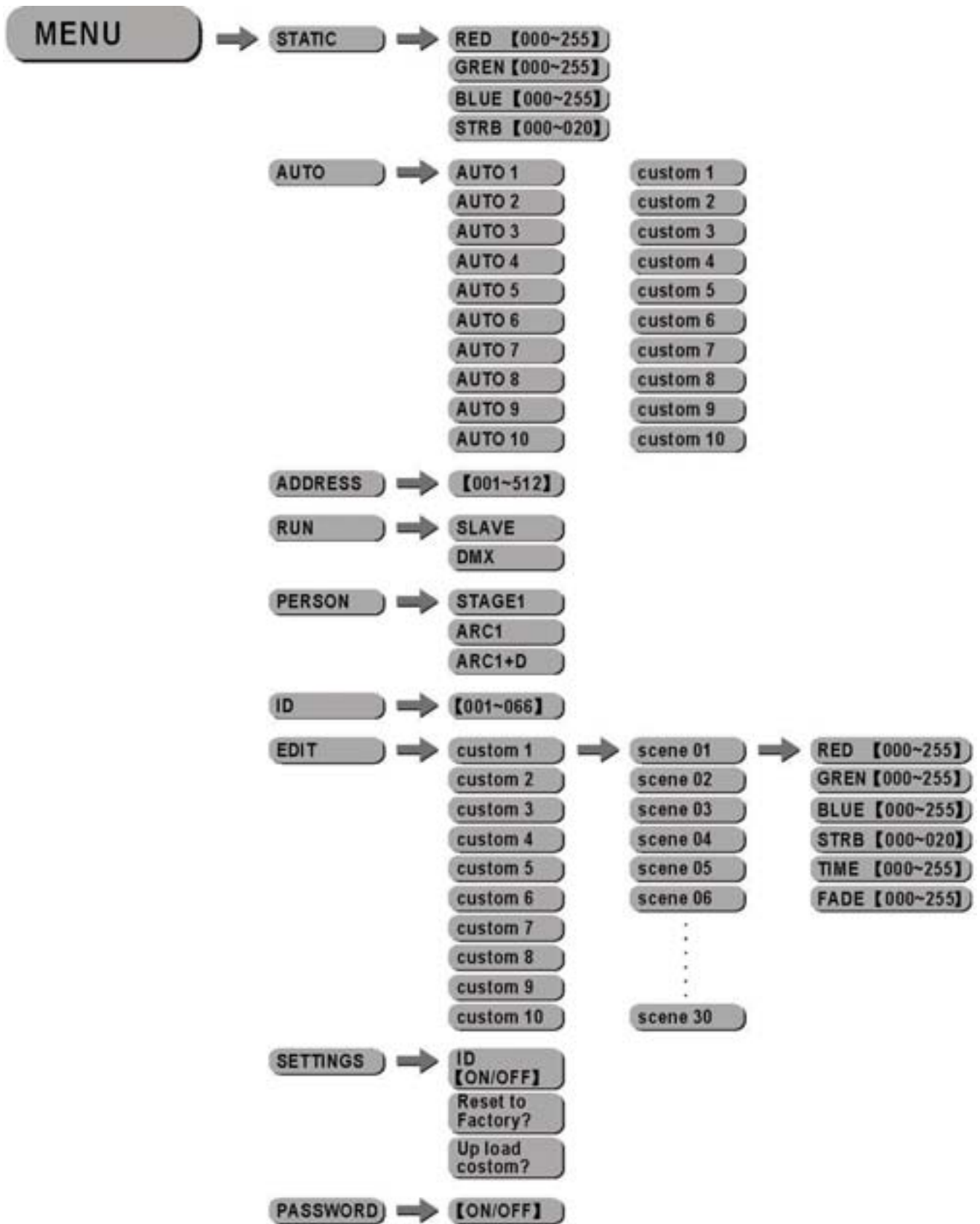

DMX512 Channel Values

The COLORDASH™ PARhas 3 DMX512 channel configurations [STAGE1, ARC1, and ARC1+D].

STAGE 1

CHANNEL	VALUE	FUNCTION
1	000 ⇔ 255	Dimmer 0 ⇔ 100%
2	000 ⇔ 255	Red (or STEP TIME when CUS.01-10 is activated) 0 ⇔ 100%
3	000 ⇔ 255	Green (or FADE TIME when CUS.01-10 is activated) 0 ⇔ 100%
4	000 ⇔ 255	Blue 0 ⇔ 100%
5	000 ⇔ 010 011 ⇔ 035 036 ⇔ 060 061 ⇔ 085 086 ⇔ 110 111 ⇔ 135 136 ⇔ 160 161 ⇔ 185 186 ⇔ 210 211 ⇔ 215 216 ⇔ 220 221 ⇔ 225 226 ⇔ 230 231 ⇔ 235 236 ⇔ 240 241 ⇔ 245 246 ⇔ 250 251 ⇔ 255	Color Macro + White Balance No Function Red 100%/ Green Up/ Blue 0% Red Down/ Green 100%/ Blue 0% Red 0%/ Green 100%/ Blue Up Red 0%/ Green Down/Blue 100% Red Up/ Green 0%/Blue 100% Red 100%/ Green 0%/ Blue Down Red 100%/ Green Up/ Blue Up Red Down/ Green Down/ Blue 100% White 1:3200K White 2: 3400K White 3: 4200K White 4: 4900K White 5: 5600K White 6: 5900K White 7: 6500K White 8: 7200K White 9: 8500K
6	000 ⇔ 004 005 ⇔ 255	Strobe No Function 0 ⇔ 20Hz
7	000 ⇔ 020 021 ⇔ 030 031 ⇔ 040 041 ⇔ 050 051 ⇔ 060 061 ⇔ 070 071 ⇔ 080 081 ⇔ 090 091 ⇔ 0100 101 ⇔ 110 111 ⇔ 120 121 ⇔ 130 131 ⇔ 140 141 ⇔ 150 151 ⇔ 160 161 ⇔ 170 171 ⇔ 180 181 ⇔ 190 191 ⇔ 200 201 ⇔ 210 211 ⇔ 220 221 ⇔ 255	Auto + Custom Programs No Function Auto 1 Auto 2 Auto 3 Auto 4 Auto 5 Auto 6 Auto 7 Auto 8 Auto 9 Auto 10 Custom 1 Custom 2 Custom 3 Custom 4 Custom 5 Custom 6 Custom 7 Custom 8 Custom 9 Custom 10 No function

8 | 0 ⇔ 255 | Auto Speed

CHANNEL 9 (ID ADDRESS SELECTION)

000 ⇔ 009	All IDs	212	ID 23	235	ID 46
010 ⇔ 019	ID 1	213	ID 24	236	ID 47
020 ⇔ 029	ID 2	214	ID 25	237	ID 48
030 ⇔ 039	ID 3	215	ID 26	238	ID 49
040 ⇔ 049	ID 4	216	ID 27	239	ID 50
050 ⇔ 059	ID 5	217	ID 28	240	ID 51
060 ⇔ 069	ID 6	218	ID 29	241	ID 52
070 ⇔ 079	ID 7	219	ID 30	242	ID 53
080 ⇔ 089	ID 8	220	ID 31	243	ID 54
090 ⇔ 099	ID 9	221	ID 32	244	ID 55
100 ⇔ 109	ID 10	222	ID 33	245	ID 56
110 ⇔ 119	ID 11	223	ID 34	246	ID 57
120 ⇔ 129	ID 12	224	ID 35	247	ID 58
130 ⇔ 139	ID 13	225	ID 36	248	ID 59
140 ⇔ 149	ID 14	226	ID 37	249	ID 60
150 ⇔ 159	ID 15	227	ID 38	250	ID 61
160 ⇔ 169	ID 16	228	ID 39	251	ID 62
170 ⇔ 179	ID 17	229	ID 40	252	ID 63
180 ⇔ 189	ID 18	230	ID 41	253	ID 64
190 ⇔ 199	ID 19	231	ID 42	254	ID 65
200 ⇔ 209	ID 20	232	ID 43	255	ID 66
210	ID 21	233	ID 44		
211	ID 22	234	ID 45		

ARC

CHANNEL	VALUE	FUNCTION
1	000 ⇔ 255	Red 0 ⇔ 100%
2	000 ⇔ 255	Green 0 ⇔ 100%
3	000 ⇔ 255	Blue 0 ⇔ 100%

1

ARC

CHANNEL	VALUE	FUNCTION
1	000 ⇔ 255	Dimmer 0 ⇔ 100%
2	000 ⇔ 255	Red 0 ⇔ 100%
3	000 ⇔ 255	Green 0 ⇔ 100%
4	000 ⇔ 255	Blue 0 ⇔ 100%

1 + D

Important Notes about STAGE 1 DMX Operation

MASTER DIMMER

- Channels 1 controls the intensity of the currently projected color
- When the slider is at the highest position (255), then the intensity of the output is at the maximum.

RED, GREEN BLUE AND WHITE COLOR SELECTION

- Channels 2, 3, and 4 control the intensity ratio of each of the Red, Green, & Blue LEDs.
- Channels 2 3 and 4 can be combined together to create over 16 million color combinations.

STROBE

- Channel 6 controls the strobe of Channels 2 through 4.
- Channel 6 has priority over Channels 2, 3, & 4.
- Speed of the strobe is adjustable from 0 to 20 Hz.

COLOR MACROS

- Channel 7 selects the required Color Macro.
- Channel 7 has priority over Channels 2, 3, 4.
- Channel 1 is used to control the intensity of the current Color Macro.

ID ADDRESS SELECTION

- Use channel 9 to select the target ID address.
- Each independent DMX address can have up to 66 ID addressed fixtures.
- ID address "0" allows control of all fixtures simultaneously.

AUTO & CUSTOM PROGRAMS

- Chanel 7 selects the preset Auto/Custom programs 1~10
- When activating the Auto/Custom programs, it is then possible to control the Step time and Fade time by using Channels 2 & 3 respectively.

5. COLORADO™ CONTROLLER

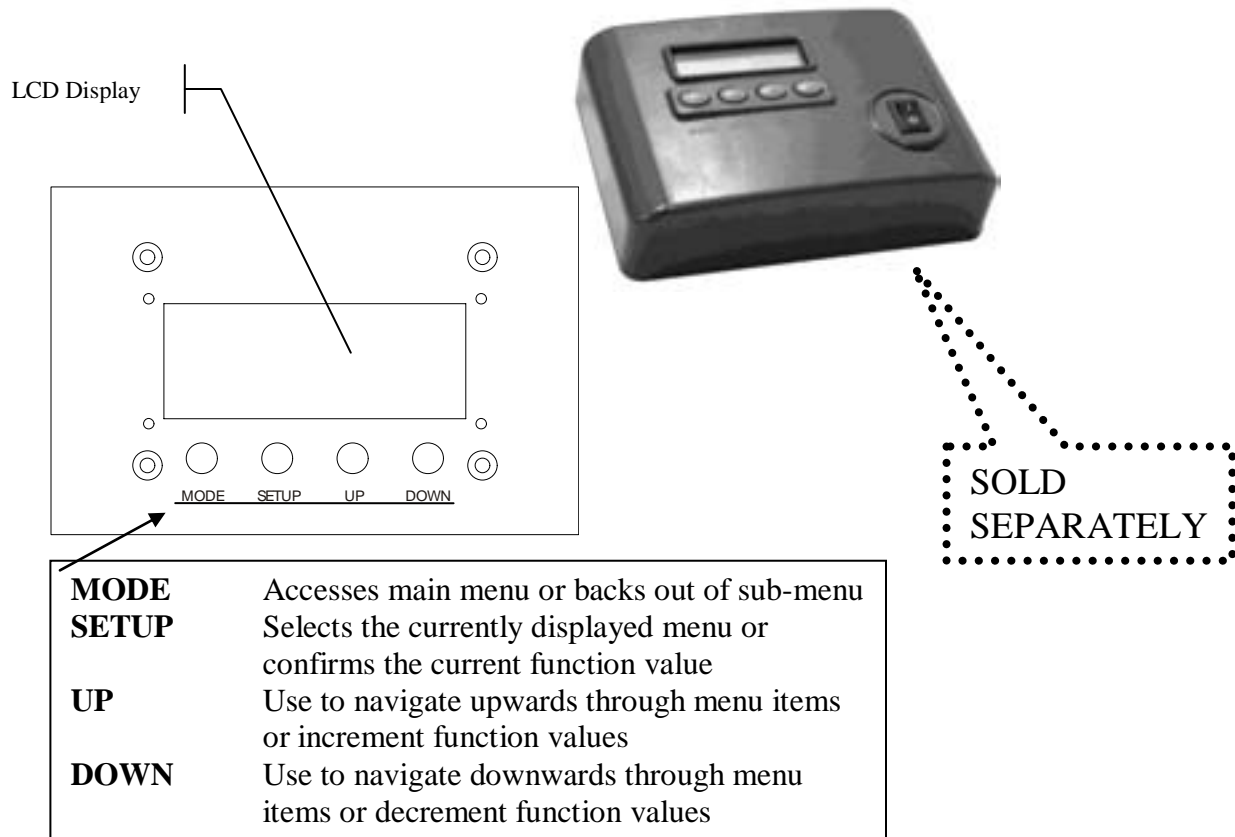

Overview

Setup

1. Connect from the OUT on the controller to the DMX Input side of the fixture using a DMX XLR cable.
2. It is recommended that you power up all COLORado units connected prior to turning on the controller. This ensures that the controller will auto-detect DMX addresses. Alternatively you can use {**Detect device**} from the {**Settings**} menu.
3. Set ID addresses on the fixtures in ascending order.
4. Set the {**Range**} in the {**Settings**} menu.

Note There is no need to set ID and Range for {**Wash**} programs.

Menu Map

MAIN FUNCTION	SELECTION	SELECTION	SELECTION	SELECTION
Wash program	Wash [1] ⇔ Wash [8]	Edit	Step time [001] ⇔ [255]	
			Fade time [001] ⇔ [255]	
Effect program	Effect [1] ⇔ Effect [8]	Edit	Speed [001] ⇔ [100]	
Custom program	Custom [1] ⇔ Custom [8]	Edit	Scene [1] ⇔ Scene [100]	ID address [000*] ⇔ [100] (*0 = all units)
				Step time [000] ⇔ [255]
				Fade time [000] ⇔ [255]
				Red [000] ⇔ [255]
				Green [000] ⇔ [255]
				Blue [000] ⇔ [255]
				Module [001] ⇔ [006]
Strobe [000] ⇔ [020]				
Play schedule	Schedule			
Clock	Time now	i.e. 12/31/2006 13:50:24		
	Edit time	i.e. 12/31/2006 13:50:24		
Schedule	Wash [1] ⇔ Wash [8]	Start>>>End 00:00>>>00:00		
	Effect [1] ⇔ Effect [8]			
	Custom [1] ⇔ Custom [8]			
Settings	DMX address	[001] ⇔ [255]		
	Range	[001] ⇔ [066]		
	Allow edit	[YES] ⇔ [NO]		
	Detect device	>>>		
	Reset to Factory settings	[YES] ⇔ [NO]		
Password	Password ON/OFF	[ON] ⇔ [OFF]		
	Set password	[]		

Wash Program

1. Select from the eight existing **[Wash]** programs and it will instantly play.
2. Set the **[Step time]** and the **[Fade time]** in the **[Edit]** function if desired.
3. The unit of time is 5 seconds and it can be adjusted between 1 and 255.

Effect Program

1. Select from the eight existing **[Effect]** programs and it will instantly play.
2. Vary the **[Speed]** of the effect between 1 and 255.

Custom Program

1. Select from the eight existing **[Custom]** programs and it will instantly play.
2. Enter the **[Edit]** section to create or edit program.
3. You can create or edit up to 100 scenes. To program less than 100 scenes, set the **[Step time]** of the scene **after** your last scene to 0.
4. Select the ID address of the target unit. Setting ID address to 0 selects all units in the serial link. Color/Effects combination for different IDs is allowed.
5. Specify the **[Module]** or modules to run active.
Note: this option is intended for use with the COLORado 3; for the COLORado 1, it will function as if **[Module]** is set to one.
0 = 1,2,3
1 = 1
2 = 2
3 = 3
4 = 1,2
5 = 2,3
6 = 1,3
6. RGB mix using the **[Red]**, **[Green]** and **[Blue]** functions and adjusting the range between 0 and 255.
7. Select a **[Strobe]** speed from 0-20Hz if desired.
8. Select the **[Step time]** for the current scene.
Step time unit values
Range 0 – 10 = 0.1sec per unit
Range 11 – 255 = 1 sec per unit
9. Set a **[Fade time]** for the current scene in one second increments from 0 to 255.

Play Schedule

Simply activate this menu **[Play schedule]** to run.

Clock

[Clock] ⇨ **[Time now]**: To view the current time on the controller.

[Clock] ⇨ **[Edit now]**: Edit the time and date.

Schedule

There are 24 **Wash**, **Effect** and **Custom** programs that can be set with Start and End times. Start times take priority over End times. Programs will not overlap. Programs with the most recent Start time will always override the existing previously executed program.

Settings

[DMX address]

This function sets the DMX address for the controller. It is addressable from 1 to 250.

[Range]

Enter the number of fixtures connected in series.

[Allow edit]

This function either enables or disables editing in **Wash**, **Effect** and **Custom** programs.

[Detect device]

This is the manual method of detecting and connecting the controller to all new units in series. It is generally used when you add more units to an existing system. Turning off and then on the controller has the same effect.

[Reset to factory settings]

This function will reset all the settings to the factory defaults except for **[Custom]** programs.

Factory Default Settings	
Setting	Default
[Schedule]	All times in schedule are reset to [00:00]
[Wash program]	Step times and fade times are reset to [001]
[Effect program]	Speeds are reset to [001]
[DMX address]	DMX address is reset to [001]
[Range]	Range is reset to [066]
[Allow edit]	Reset to [Yes]
[Password ON/OFF]	Password is reset to [OFF]
[Set password]	Password is reset to [00000000] Down=0, Up=1

Activating password mode

1. Set **[Password]** function to [ON]. This will prompt the user for a password every time the controller is powered on.
2. Toggle to **[Set password]** function in order to change the password.
3. Input an 8 digit password using the **[UP]** & **[DOWN]** keys. Press the **[SET]** button to confirm.

Note In the event that the user forgets the password use the following factory password override:

[UP] ↻ [DOWN] ↻ [UP] ↻ [DOWN] ↻ [UP] ↻ [UP] ↻ [DOWN] ↻ [DOWN]

Control via external DMX

Programs in the controller can be accessed via an external DMX controller. It will be necessary to have the DMX address set on the COLORado Controller. The controller operates on 4 channels of control.

DMX Channel Values

CHANNEL	VALUE	FUNCTION
1	000 ⇔ 010	Blackout
	011 ⇔ 030	Wash [1]
	031 ⇔ 040	Blackout
	041 ⇔ 060	Wash [2]
	061 ⇔ 070	Blackout
	071 ⇔ 090	Wash [3]
	091 ⇔ 100	Blackout
	101 ⇔ 120	Wash [4]
	121 ⇔ 130	Blackout
	131 ⇔ 150	Wash [5]
	151 ⇔ 160	Blackout
	161 ⇔ 180	Wash [6]
	181 ⇔ 190	Blackout
	191 ⇔ 210	Wash [7]
	211 ⇔ 220	Blackout
	221 ⇔ 255	Wash [8]
2	000 ⇔ 010	Blackout
	011 ⇔ 030	Effect [1]
	031 ⇔ 040	Blackout
	041 ⇔ 060	Effect [2]
	061 ⇔ 070	Blackout
	071 ⇔ 090	Effect [3]
	091 ⇔ 100	Blackout
	101 ⇔ 120	Effect [4]
	121 ⇔ 130	Blackout
	131 ⇔ 150	Effect [5]
	151 ⇔ 160	Blackout

	161 ⇔ 180	Effect [6]
	181 ⇔ 190	Blackout
	191 ⇔ 210	Effect [7]
	211 ⇔ 220	Blackout
	221 ⇔ 255	Effect [8]
3	000 ⇔ 010	Blackout
	011 ⇔ 030	Custom [1]
	031 ⇔ 040	Blackout
	041 ⇔ 060	Custom [2]
	061 ⇔ 070	Blackout
	071 ⇔ 090	Custom [3]
	091 ⇔ 100	Blackout
	101 ⇔ 120	Custom [4]
	121 ⇔ 130	Blackout
	131 ⇔ 150	Custom [5]
	151 ⇔ 160	Blackout
	161 ⇔ 180	Custom [6]
	181 ⇔ 190	Blackout
191 ⇔ 210	Custom [7]	
211 ⇔ 220	Blackout	
221 ⇔ 255	Custom [8]	
4	000 ⇔ 127	OFF
	128 ⇔ 255	ON

Technical Support

Address: Service Dept.
 3000 N 29th Ct, Hollywood, FL 33020 (U.S.A.)
 Support (Email): tech@chauvetlighting.com
 Telephone: (954) 929-1115 - (Press 4)
 Fax: (954) 929-5560 - (Attention: Service)
 Website: <http://www.chauvetlighting.com>

Contact Us

World Wide

General Information

Chauvet Lighting
 3000 North 29th Court
 Hollywood, FL 33020
 voice: 954.929.1115
 fax: 954.929.5560
 toll free: 800.762.1084)

World Wide Web

www.chauvetlighting.com

6. APPENDIX

DMX Primer

There are 512 channels in a DMX-512 connection. Channels may be assigned in any manner. A fixture capable of receiving DMX 512 will require one or a number of sequential channels. The user must assign a starting address on the fixture that indicates the first channel reserved in the controller. There are many different types of DMX controllable fixtures and they all may vary in the total number of channels required. Choosing a start address should be planned in advance. Channels should never overlap. If they do, this will result in erratic operation of the fixtures whose starting address is set incorrectly. You can however, control multiple fixtures of the same type using the same starting address as long as the intended result is that of unison movement or operation. In other words, the fixtures will be slaved together and all respond exactly the same.

DMX fixtures are designed to receive data through a serial Daisy Chain. A Daisy Chain connection is where the DATA OUT of one fixture connects to the DATA IN of the next fixture. The order in which the fixtures are connected is not important and has no effect on how a controller communicates to each fixture. Use an order that provides for the easiest and most direct cabling. Connect fixtures using shielded two conductor twisted pair cable with three pin XLR male to female connectors. The shield connection is pin 1, while pin 2 is Data Negative (S-) and pin 3 is Data positive (S+). CHAUVET carries 3-pin XLR DMX compliant cables, DMX-10 (33'), DMX-4.5 (15') and DMX-1.5 (5')

General Maintenance

To maintain optimum performance and minimize wear fixtures should be cleaned frequently. Usage and environment are contributing factors in determining frequency. As a general rule, fixtures should be cleaned at least twice a month. Dust build up reduces light output performance and can cause overheating. This can lead to reduced lamp life and increased mechanical wear. Be sure to power off fixture before conducting maintenance.

Unplug fixture from power. Use a vacuum or air compressor and a soft brush to remove dust collected on external vents and internal components. Clean all glass when the fixture is cold with a mild solution of glass cleaner or Isopropyl Alcohol and a soft lint free cotton cloth or lens tissue. Apply solution to the cloth or tissue and drag dirt and grime to the outside of the lens. Gently polish optical surfaces until they are free of haze and lint.

The cleaning of internal and external optical lenses and/or mirrors must be carried out periodically to optimize light output. Cleaning frequency depends on the environment in which the fixture operates: damp, smoky or particularly dirty surrounding can cause greater accumulation of dirt on the unit's optics. Clean with soft cloth using normal glass cleaning fluid. - Always dry the parts carefully. - Clean the external optics at least every 20 days. Clean the internal optics at least every 30/60 days.

Returns Procedure

Returned merchandise must be sent prepaid and in the original packing, call tags will not be issued. Package must be clearly labeled with a Return Merchandise Authorization Number (RA #). Products returned without an RMA # will be refused. Call CHAUVET and request RA # prior to shipping the fixture. Be prepared to provide the model number, serial number and a brief description of the cause for the return. Be sure to properly pack fixture, any shipping damage resulting from inadequate packaging is the customer's responsibility. CHAUVET reserves the right to use its own discretion to repair or replace product(s). As a suggestion, proper UPS packing or double-boxing is always a safe method to use.

Note: If you are given an RMA #, please include the following information on a piece of paper inside the box:

- 1) Your name
- 2) Your address
- 3) Your phone number
- 4) The RMA #
- 5) A brief description of the symptoms

Claims

Damage incurred in shipping is the responsibility of the shipper; therefore the damage must be reported to the carrier upon receipt of merchandise. It is the customer's responsibility to notify and submit claims with the shipper in the event that a fixture is damaged due to shipping. Any other claim for items such as missing component/part, damage not related to shipping, and concealed damage, must be made within seven (7) days of receiving merchandise.

Photometrics

RED

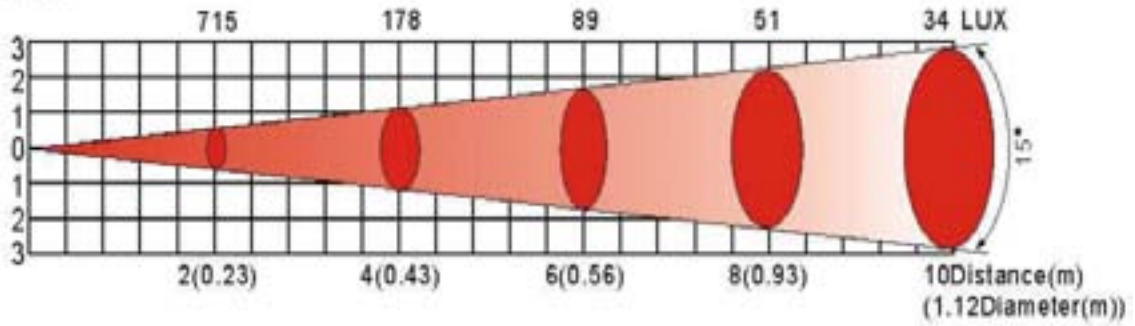

GREEN

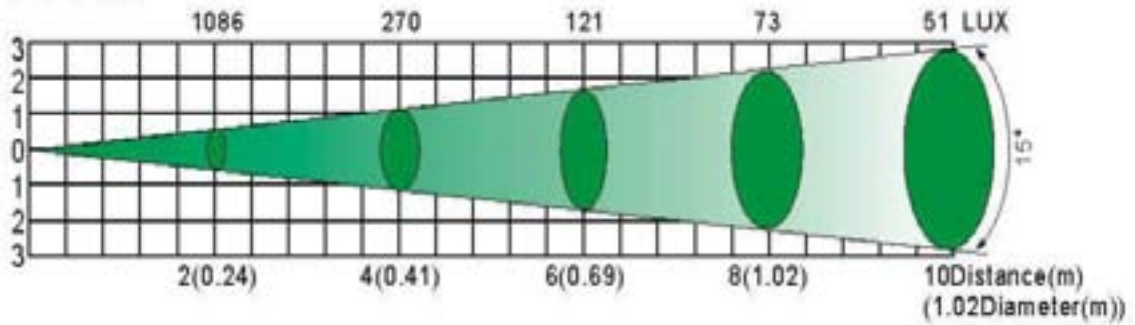

BLUE

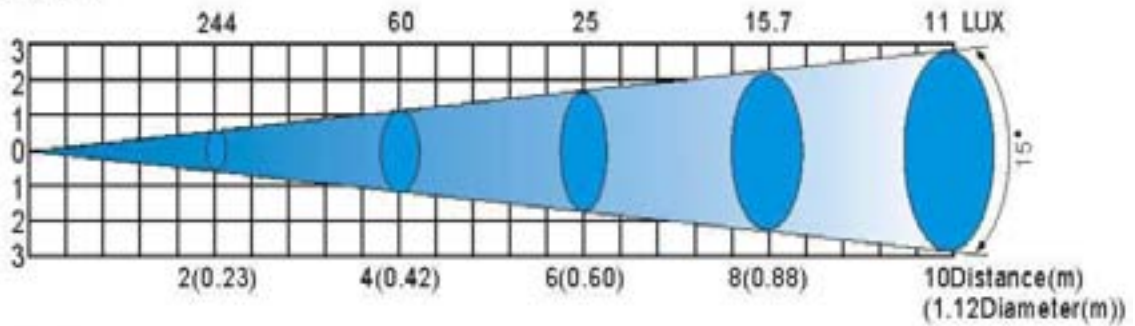

RGB

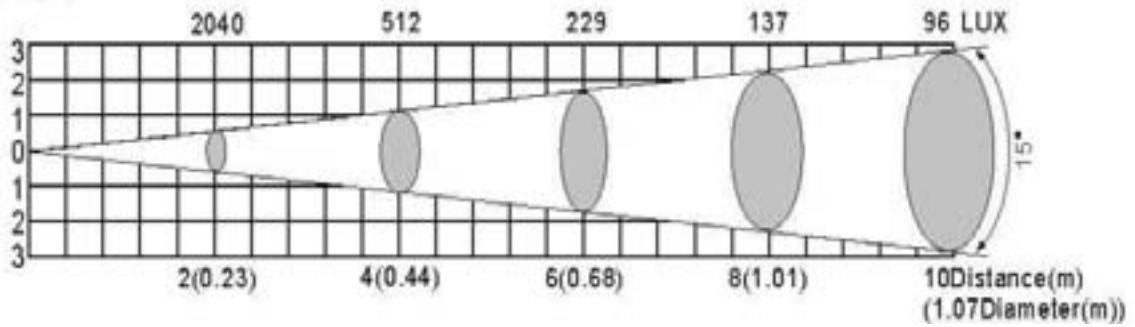

COLORDASH™ PARService Maintenance Guide

Symptom(s)	Possible Solution(s)
1 or more LED's are not illuminating	Clean the fixture regularly to avoid any such failure. This fixture is convection cooled, which means that if the surface is kept clean and free of debris, then proper cooling will be allowed to occur
	An LED may have failed, resulting in an open circuit. In this event, all of the red, green, or blue in a single module will no longer illuminate. This does not mean that all of the LEDs have failed, but the circuit is wired in series.
	An LED may have failed, resulting in a short circuit. In this event, only the single LED which has failed will no longer function. This does not mean that all of the LEDs have failed, but the circuit is wired in series.
	<i>-Note: In the event of LED failure, a replacement LED PCB assembly may be purchased directly from Chauvet Part#: P222-M1LEDP</i>
1 or more LED's are producing very low output	Check that the lens assembly is installed properly. If the lens assembly is not aligned properly over the LEDs, then they will not project fully <i>-See section on Lens Assembly Installation</i>
	<i>-Note: In the event of LED failure, a replacement LED PCB assembly may be purchased directly from Chauvet Part#: P222-M1LEDP</i>
Breaker/Fuse keeps blowing	Check total load placed on the electrical circuit
	Check for a short in the electrical wiring: internal and/or external
Device has no power	Check device's fuse (internal)
	Check for power on Mains
	Check cable connections The COLORDash™ PAR cables must be firmly connected for operation
	<i>-Note: In the event of autoswitching transformer failure, the unit can be sent in for repair; however, a replacement part can be ordered directly from Chauvet Part#: P140-M1ELTR</i>
Fixture is not responding to DMX	Check Control Panel settings for correct addressing
	Check DMX cables
	Check polarity switch settings on the controller
	Check cable connections
	Call service technician
	<i>-Note: In the event of Master PCB failure, a replacement PCB can be ordered directly from Chauvet Part#: P170-MINIPD</i>
Loss of signal	Use only DMX cables
	Install terminator
	Note: Keep DMX cables separated from power cables or black lights
COLOR-CON Controller does not function, or does not function properly	Make sure connector is firmly connected to device
	The COLORDash™ PAR fixture must be in the correct mode in order to properly respond to the COLOR-CON controller. The correct mode is "SLAVE" in the onboard Control Panel
Stand alone operation	This fixture has built-in, automatic programs that may be triggered from the onboard Control Panel

If you still have a problem after trying the above solutions, please contact CHAUVET Technical Support at the location on page 28.

Blow-out Diagram.

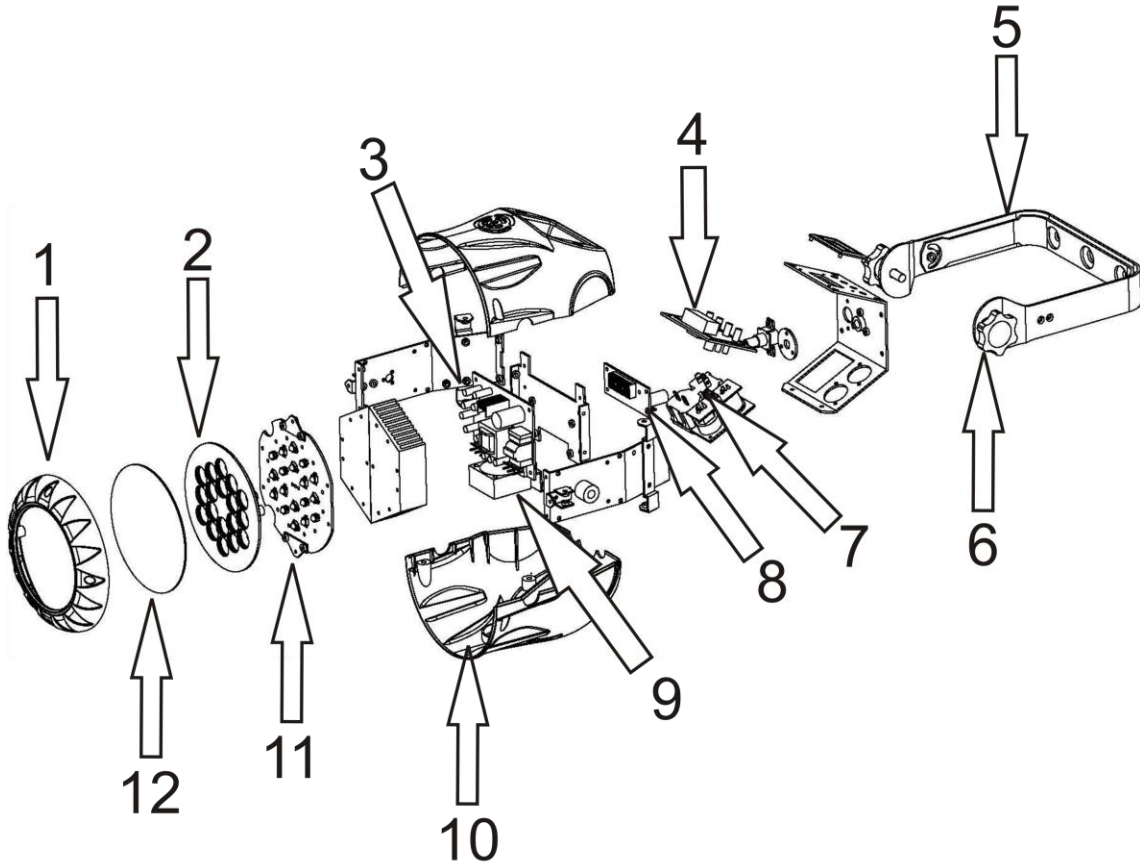

	Description	Part Number
1	Front Rim Cover	P111-M1RCVR
2	LED lens assembly	CL18X10/15/30
3	Electronic Transformer 90-240V 50/60Hz	P140-M1ELTR
4	Display/Master PCB	P170-MINIPD
5	Bracket/Floor stand	P111-PARBRKT
6	Bracket Knob	P111-M1KNOB
7	Power/signal input/output	P111-M1PWR(POWER) P111-M1SIG(SIGNAL)
8	LED Driver PCB	P172-MIN1DVR
9	Cooling fan	P130-40MM24V
10	Main Case Cover (X2)	P111-MINPARC
11	LED metal-core PCB assembly	P222-M1LEDP
12	Plastic clear lens cover	P111-M1LCVR

Connection Drawing

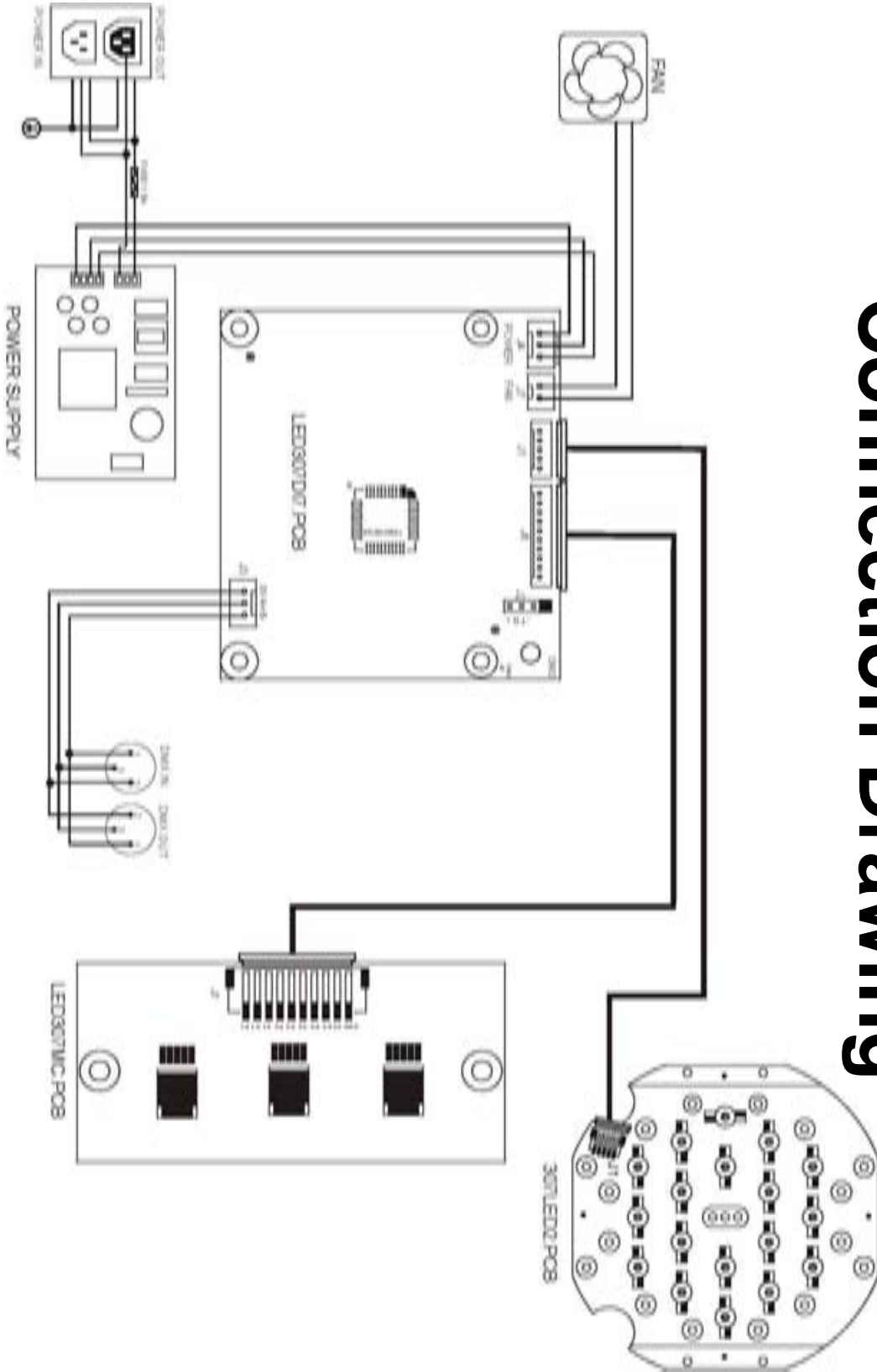

Technical Specifications

WEIGHT & DIMENSIONS

Length.....	14 in (356 mm)
Width.....	8.5 in (216 mm)
Height.....	6 in (152 mm)
Weight.....	5.8 lbs (2.6 kg)

POWER

AC Power Auto-switching	100V~240V 50/60Hz AC
Power Consumption	30W (0.4A) max at 120V 60Hz
Power Consumption	30W (0.4A) max at 240V 60Hz
Inrush Current	(1.4A) at 120V 60Hz
Power Factor.....	0.60 at 120V 60Hz
Power Factor.....	0.41 at 240V 50Hz
Additional Power Output	25 units max @120V
Additional Power Output	50 units max @240V

LIGHT SOURCE

Quantity.....	18 (6 Red, 6 Blue, 6 Green)
LED (normal).....	1W 350mA 50,000 hrs

PHOTO OPTIC (WITH 15° LENSES)

Luminance @ 1m	7400 lux
Beam Angle.....	12°
Field Angle	24°

COOLING

Forced Convection Cooled	50mm 24V fan
--------------------------------	--------------

CONTROL & PROGRAMMING

Data input.....	locking 3-pin XLR male socket
Data output.....	locking 3-pin XLR female socket
Data pin configuration.....	pin 1 shield, pin 2 (-), pin 3 (+)
Protocols	DMX-512 USITT
DMX Channels	User Configurable: 3, 4, 5, or 9

STANDARD ORDERING INFORMATION

COLORdash™ PAR	COLORDASHPAR
15° Optical Lens kit (20pcs)	installed
30° Optical Lens kit (20pcs)	CL20X30
Power extension cable.....	EXT-2

SPARE PARTS ORDERING INFORMATION

Electronic Transformer (Part).....	P140-M1ELTR
Display/Master PCB (Part).....	P170-MINIPD
LED Driver PCB (Part).....	P172-MIN1DVR
LED Metal-Core PCB: assembled (Part)	P222-M1LEDP
Front Lens Replacement UV-coated Cover (Part)	P111-M1LCVR
Bracket/floor stand assembly (Part)	P111-PARBRKT
Display/Master IC chip (Part).....	P177-M1MIC
Bracket adjustment knob (Part).....	P111-M1KNOB
Red 1W 350mA LED SINGLE (Part).....	P222-CORLED
Green 1W 350mA LED SINGLE (Part).....	P222-COGLED
Blue 1W 350mA LED SINGLE (Part)	P222-COBLED
Cooling fan (Part)	P130-40MM24V
Main case cover (X2) (Part).....	P111-MINPARC
Front rim case cover (X2) (Part).....	P111-M1RCVR

OPTIONAL CONTROLLER

COLORado™ Controller.....	COLOR-CON
---------------------------	-----------

WARRANTY INFORMATION

Warranty	2-year limited warranty
----------------	-------------------------