

LED PAR 64-36B
LED PAR 64-36C

Snapshot

Use on Dimmer	⊘
Outdoor Use	⊘
Sound Activated	✓
DMX	✓
Master/Slave	✓
Autoswitching Power Supply	✓
Replaceable Fuse	✓
User Serviceable	⊘
Duty Cycle	⊘

User Manual

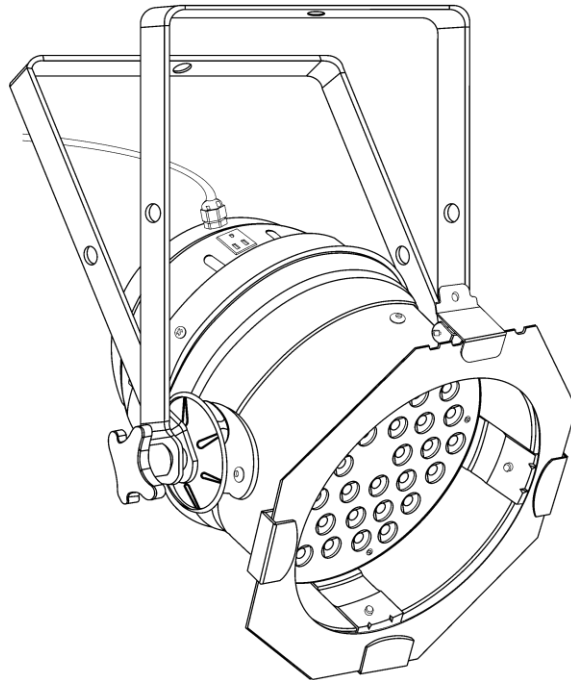

3000 N 29th Ct, Hollywood, FL 33020 U.S.A.
(800) 762-1084 – (954) 929-1115
FAX (954) 929-5560
www.chauvetlighting.com

TABLE OF CONTENTS

1. BEFORE YOU BEGIN	3
WHAT IS INCLUDED	3
UNPACKING INSTRUCTIONS	3
MANUAL CONVENTIONS	3
ICONS	3
SAFETY INSTRUCTIONS	4
2. INTRODUCTION	5
FEATURES	5
<i>Additional Features</i>	5
PRODUCT OVERVIEW	5
PHOTOMETRICS	6
PRODUCT OVERVIEW	7
3. SETUP	8
AC POWER.....	8
<i>Power Linking</i>	8
MOUNTING.....	9
<i>Orientation</i>	9
<i>Rigging</i>	9
FIXTURE LINKING.....	10
<i>Data Cabling</i>	10
<i>DMX Data Cable</i>	10
<i>Cable Connectors</i>	10
<i>3-Pin to 5-Pin Conversion Chart</i>	11
<i>Setting up a DMX Serial Data Link</i>	11
4. OPERATING INSTRUCTIONS	12
<i>DMX Operation</i>	12
<i>Accessing the 2 Personalities:</i>	12
<i>Master/Slave Mode (Sound-Active, Auto Mode):80</i>	12
<i>Strobe Speed:</i>	12
STANDALONE OPERATION.....	13
<i>Automatic</i>	13
<i>Sound-Active</i>	13
<i>Static Colors</i>	13
<i>Fixture Linking</i>	13
DMX CHANNEL VALUES	14
SETTING THE STARTING ADDRESS	15
GENERAL TROUBLESHOOTING	15
CONTACT US	15
5. APPENDIX	16
DMX PRIMER	16
GENERAL MAINTENANCE.....	16
RETURNS PROCEDURE	17
CLAIMS	17
TECHNICAL SPECIFICATIONS	18

1. BEFORE YOU BEGIN

What is included

- 1 x LED PAR 64-36 B/C
- 1 x Gel Frame
- 1 x Warranty Card
- 1 x User Manual

Unpacking Instructions

Immediately upon receiving a fixture, carefully unpack the carton, check the contents to ensure that all parts are present, and have been received in good condition. Notify the shipper immediately and retain packing material for inspection if any parts appear damaged from shipping or the carton itself shows signs of mishandling. Save the carton and all packing materials. In the event that a fixture must be returned to the factory, it is important that the fixture be returned in the original factory box and packing.



Manual Conventions

CHAUVET manuals use the following conventions to differentiate certain types of information from the regular text.

CONVENTION	MEANING
[10]	A DIP switch to be configured
<Menu>	A key to be pressed on the fixture's control panel
1~512	A range of values
50/60	A set of values of which only one can be chosen
Settings	A menu option not to be modified (for example, showing the operating mode/current status)
MENU > Settings	A sequence of menu options to be followed
ON	A value to be entered or selected

Icons

This manual uses the following icons to indicate information that requires special attention on the part of the user.

ICONS	MEANING
	This paragraph contains critical installation, configuration or operation information. Failure to comply with this information may render the fixture partially or completely inoperative, cause damage to the fixture or cause harm to the user.
	This paragraph contains important installation or configuration information. Failure to comply with this information may prevent the fixture from functioning correctly.
	This paragraph reminds you of useful, although not critical, information.

Safety Instructions



Please read these instructions carefully. It includes important information about the installation, usage and maintenance of this product.

- Please keep this User Manual for future consultation. If you sell the unit to another user, be sure that they also receive this instruction booklet.
- Always make sure that you are connecting to the proper voltage, and that the line voltage you are connecting to is not higher than that stated on the decal or rear panel of the fixture.
- This product is intended for indoor use only! To prevent risk of fire or shock, do not expose fixture to rain or moisture.
- Make sure there are no flammable materials close to the unit while operating.
- The unit must be installed in a location with adequate ventilation, at least 20 in (50 cm) from adjacent surfaces. Be sure that no ventilation slots are blocked.
- Always disconnect from power source before servicing or replacing fuse and be sure to replace with same fuse source.
- Secure fixture to fastening device using a safety chain.
- Maximum ambient temperature (Ta) is 104° F (40° C). Do not operate fixture at temperatures higher than this.
- In the event of a serious operating problem, stop using the unit immediately. Never try to repair the unit by yourself. Repairs carried out by unskilled people can lead to damage or malfunction. Please contact the nearest authorized technical assistance center.
- Never connect the device to a dimmer pack.
- Make sure the power cord is never crimped or damaged.
- Never disconnect the power cord by pulling or tugging on the cord.
- Never carry the fixture directly from the cord. Always use the hanging/mounting bracket.
- Avoid direct eye exposure to the light source while it is on.

2. INTRODUCTION

Features

- 3 or 7-channel DMX LED PAR can
- Operating modes:
 - 3-channel: RGB control
 - 7-channel: RGB, macros, run/strobe speed, automatic/sound, dimmer
- Static colors and RGB color mixing with or without DMX controller
- Built-in automated programs via master/slave or DMX with variable speed
- Built-in sound activated programs via master/slave or DMX
- Pulse effect with adjustable speed

Additional Features

- Available in black or chrome
- High-power, 1 W, 350 mA LEDs
- Additional power output: 10 units max
- Double-bracket yoke doubles as floor stand
- Includes gel frame

Product Overview

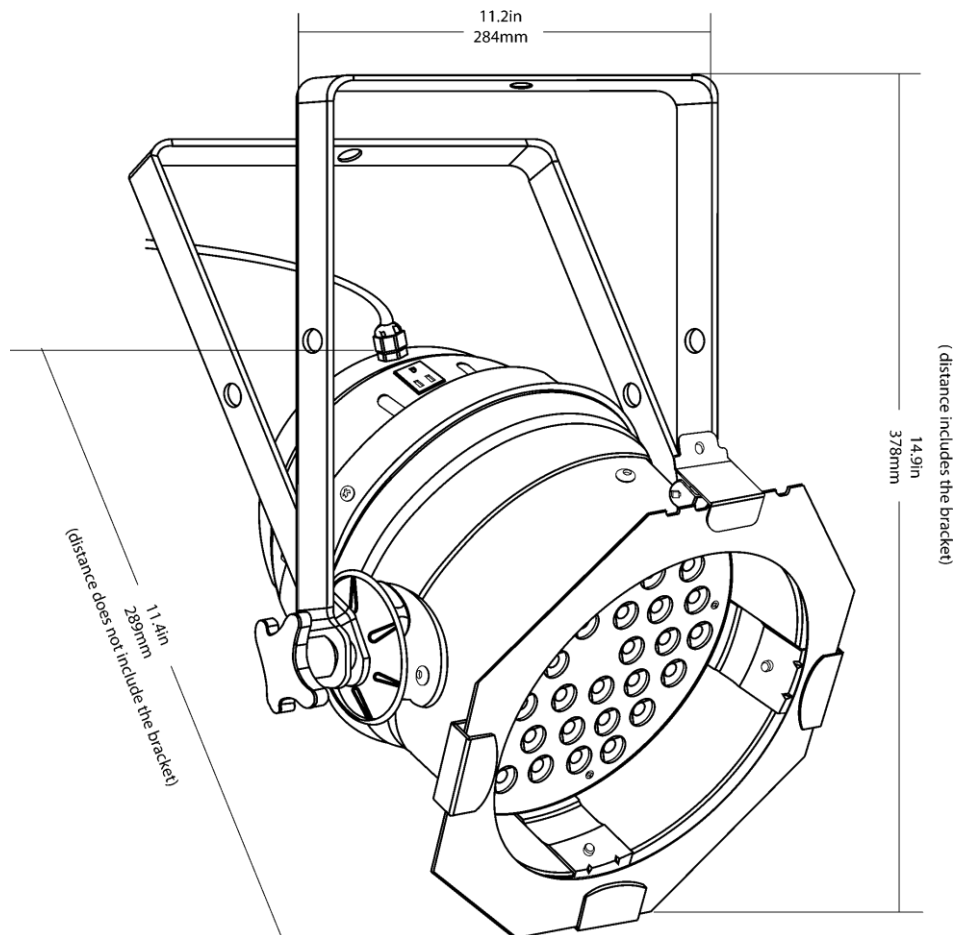

Photometrics

The photometric readings have been provided at 1 m, 3 m, and 5 m. Below, you will find a 3-dimensional drawing of the beam and field angles, along with lux and beam diameter for the field and beam angles.

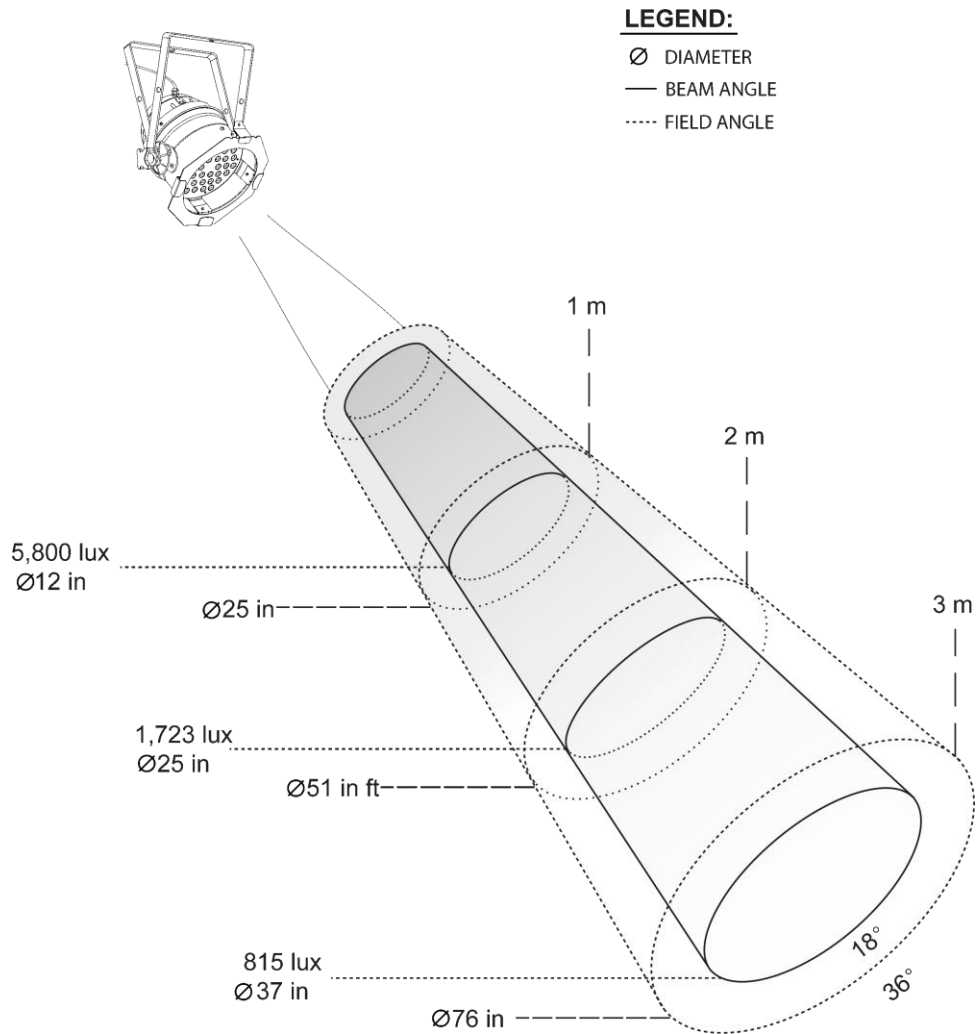

The lux measurements provided are maximum outputs at the distances stated

Product Overview

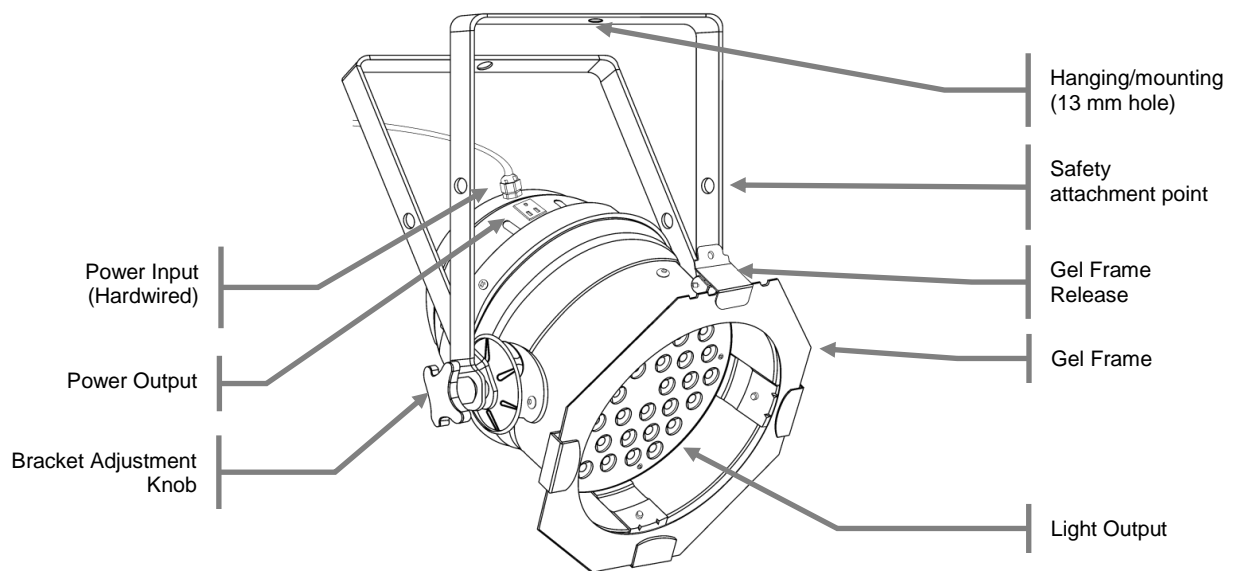
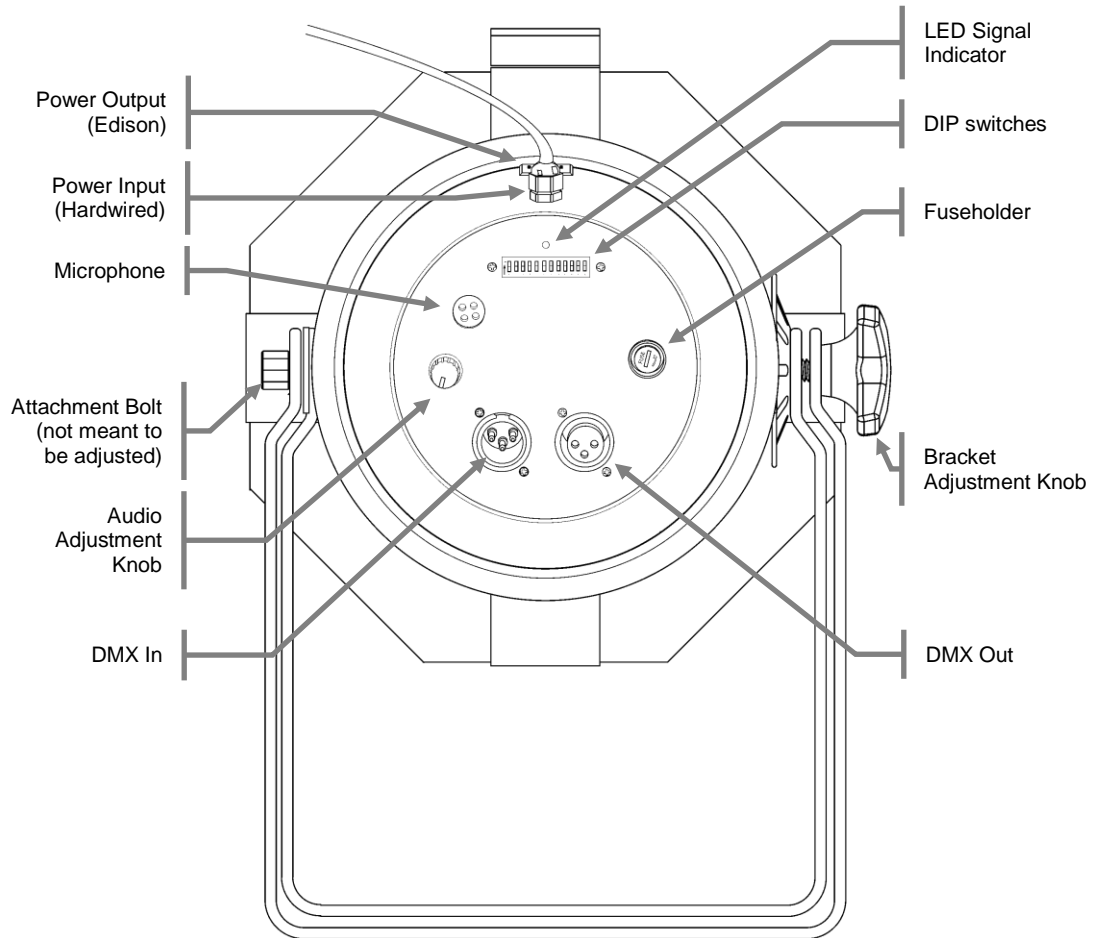

3. SETUP

AC Power

This fixture runs on 100~240 VAC, 50/60 Hz. Before powering on the unit, make sure the line voltage to which you are connecting it is within the range of accepted voltages.



Always connect the fixture to a switched circuit. Never connect the fixture to a rheostat (variable resistor) or dimmer circuit, even if the rheostat or dimmer channel is used only as a 0 to 100% switch.

To determine the power requirements for a particular fixture, see the label affixed to the back plate of the fixture or refer to the fixture's specifications chart. A fixture's listed current rating indicates its average current draw under normal conditions.



Always connect the fixture to a circuit with a suitable electrical ground.

Power Linking

This fixture contains power linking via the edison outlet located in front of the power input cable. Please see the diagram below for further explanation.



The maximum quantity of fixtures that may be linked is 10.

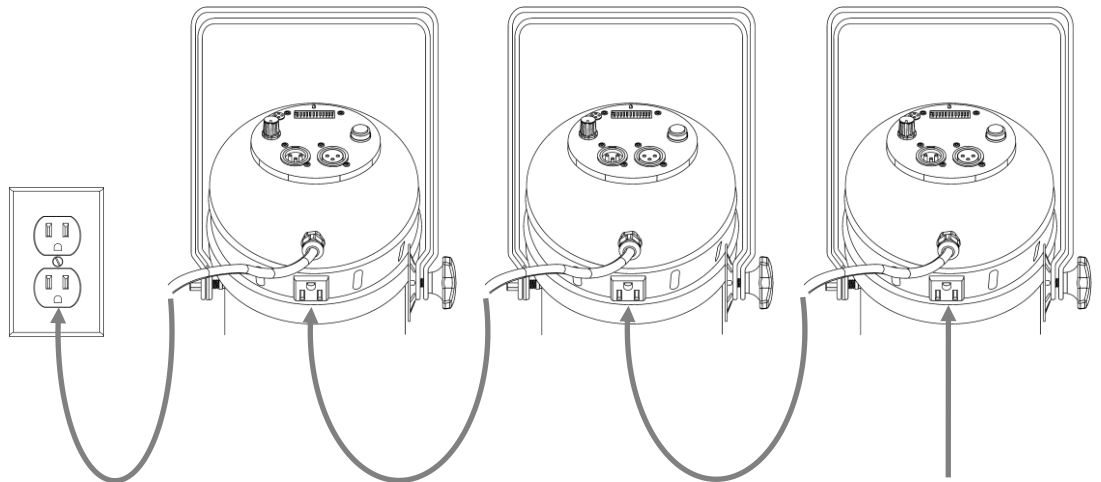

Additional power
link out

Mounting

Orientation

The LED PAR 64-36 B/C may be mounted in any safe position provided there is adequate room for ventilation.

Rigging

Be sure that the structure can support the weight of the fixture. Please see the "Technical Specifications" section of this manual for a detailed weight listing. Mount the fixture securely. This may be done with a screw, nut and bolt, or a hanging clamp. The hole in each bracket is 13 mm in size. When rigging consider routine maintenance and control panel access. Please see the following steps for installation.

- Be sure to orient the gel frame release so that it is pointing up. Please see the diagram below for a visual reference.
- If the power link out is intended to be used with multiple fixture, take into account the length of each power cable, and mount the fixtures close enough to one another to accommodate for this.
- When aiming the fixtures, you may use the bracket adjustment knob. Loosen the knob, adjust to the desired angle, and then tighten the knob by turning clockwise. Do not use tools for this step, as it may cause damage.
- There is a secondary portion of the bracket, which may be used primarily for floor standing positions.
- Safety cables must always be used.

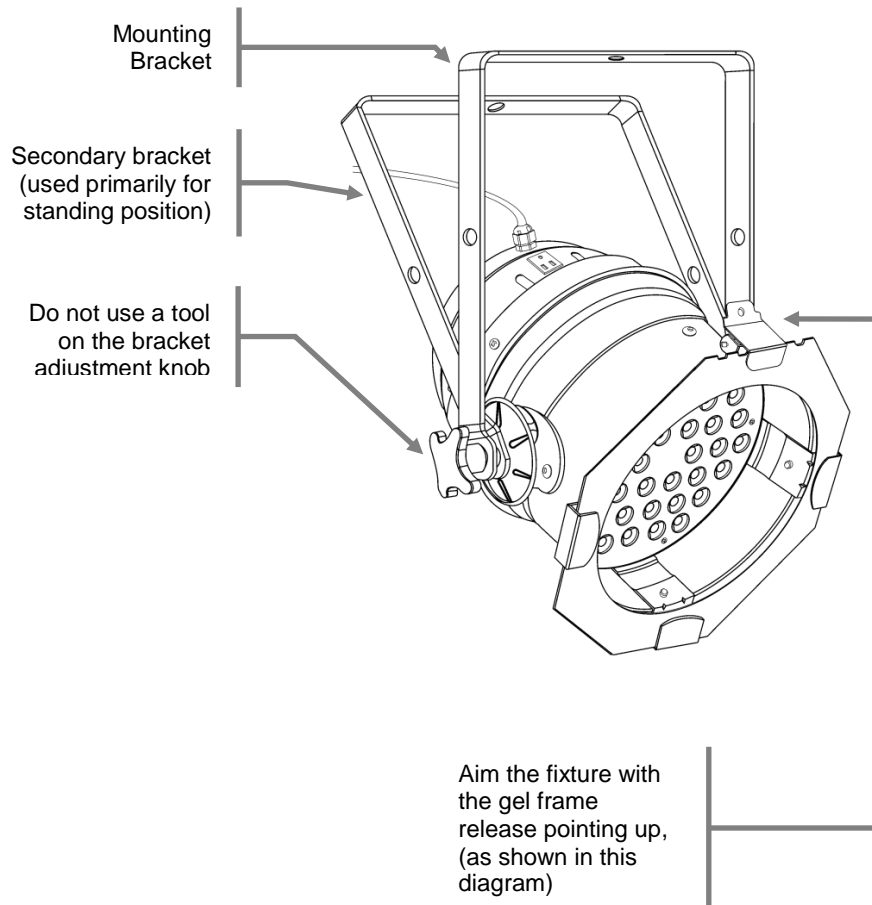

Fixture Linking

You will need a serial data link to run light shows of one or more fixtures using a DMX controller or to run synchronized shows on two or more fixtures set to a master/slave operating mode. The combined number of channels required by all the fixtures on a serial data link determines the number of fixtures the data link can support.



Fixtures on a serial data link must be daisy chained in one single line. To comply with the EIA-485 standard, no more than 32 fixtures should be connected on one data link. Connecting more than 32 fixtures on one serial data link without the use of a DMX optically-isolated splitter may result in deterioration of the digital DMX signal.

Maximum recommended serial data link distance: 500 m (1640 ft)

Maximum recommended number of fixtures on a serial data link: 32

Data Cabling

To link fixtures together you must obtain data cables. You can purchase CHAUVET certified DMX cables directly from a dealer/distributor or construct your own cable. If you choose to create your own cable please use data-grade cables that can carry a high quality signal and are less prone to electromagnetic interference.

DMX Data Cable

Use a Belden© 9841 or equivalent cable which meets the specifications for EIA RS-485 applications. Standard microphone cables cannot transmit DMX data reliably over long distances. The cable must have the following characteristics:

Type:	shielded, 2-conductor twisted pair
Maximum capacitance between conductors:	30 pF/ft
Maximum capacitance between conductor and shield:	55 pF/ft
Maximum resistance:	20 ohms/1000 ft
Nominal impedance:	100 ~ 140 ohms

Cable Connectors

Cabling must have a male XLR connector on one end and a female XLR connector on the other end.

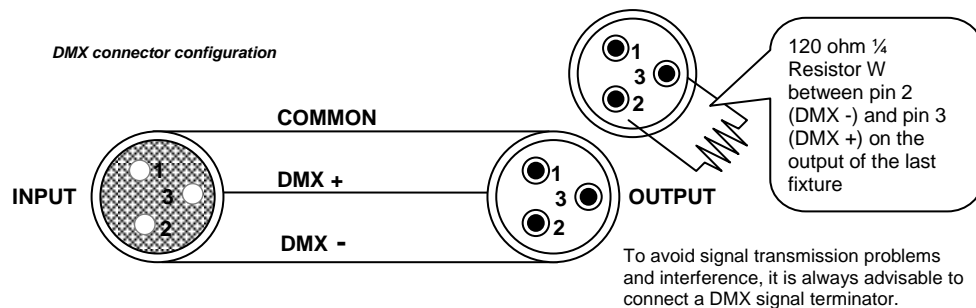

Do not allow contact between the common and the fixture's chassis ground. Grounding the common can cause a ground loop, and your fixture may perform erratically. Test cables with an ohm meter to verify correct polarity and to make sure the pins are not grounded or shorted to the shield or each other.

3-Pin to 5-Pin Conversion Chart



If you use a controller with a 5-pin DMX output connector, you will need to use a 5-pin to 3-pin adapter. The chart below details a proper cable conversion:

3-PIN TO 5-PIN CONVERSION CHART		
Conductor	3-Pin Female (Output)	5-Pin Male (Input)
Ground/Shield	Pin 1	Pin 1
Data (-) signal	Pin 2	Pin 2
Data (+) signal	Pin 3	Pin 3
Not used		Pin 4
Not used		Pin 5

Setting up a DMX Serial Data Link

1. Connect the (male) 3-pin connector side of the DMX cable to the output (female) 3-pin connector of the controller.
2. Connect the end of the cable coming from the controller which will have a (female) 3-pin connector to the input connector of the next fixture consisting of a (male) 3-pin connector.
3. Then, proceed to connect from the output as stated above to the input of the following fixture and so on.

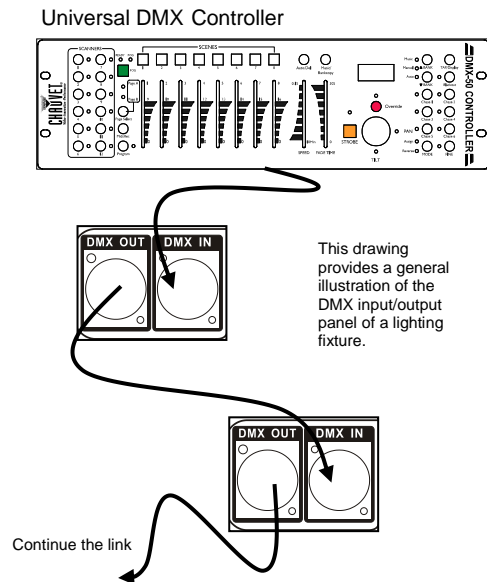

4. OPERATING INSTRUCTIONS

DMX Operation

This is the operating mode which will allow for control with an external DMX controller. You must set the starting address for this mode. If this is your first time using DMX, then it is recommended that you refer to the “DMX Primer” section in the “Appendix” of this manual.

Mode	DIP switches
DMX	1-9 = set to the DMX starting address 10 = Off

Accessing the 2 Personalities:

There are two personalities for this fixture. There is the standard 7-channel personality with strobe and color macros, and then there is the basic 3-channel RGB personality. Please see the DIP switch settings to access each of these personalities below.

Mode	DIP switches
7-CH	11-12 = Off
3-CH	11 = On

Master/Slave Mode (Sound-Active, Auto Mode, Static Colors):

This mode allows a single unit to run a standalone program, while 1 or more other units follow the same operation. This requires the fixtures to be linked with DMX cables. Please see the section on *Fixture Linking*.

- 1) Turn switch to the Slave position on the slave units, and they will react the same as the Master.

Mode	DIP switches
Slave	1-11 = Off

Strobe Speed:

This fixture has a strobe speed adjustment which will make it compatible with CHAUVET LED PAR 64-36 models produced before July of 2009. Please see the setting below for lowering the strobe rate for compatibility mode.

Mode	DIP switches
Compatibility mode 6 Hz-18 Hz:	12 = On
Decreased Speed 2 Hz-6 Hz:	12 = Off

Standalone Operation

Automatic

This fixture has a preprogrammed color fade program. This is accessed via the DIP switches on the back of the fixture, and the speed may be increased, as well. Please see the chart below for further explanation.

Mode	DIP switches
Master Auto	7, 9, 10 = On
Increase Speed	1-6 = On (add more DIP switches to reach higher speed)

Sound-Active

This fixture has preprogrammed sound triggered chases. These are accessed via the DIP switches on the back of the fixture, and the sensitivity may be adjusted using the audio adjustment knob. Please see the chart below for further explanation.

Mode	DIP switches
Master Sound	10 = On

Static Colors

This unit has separate DIP switches for each of the 3 colors (red, green, and blue). These are accessed via the DIP switches on the back of the fixture. Each of the 3 color may be mixed with different intensities. Please see the chart below for further explanation.

Mode	DIP switches
Master Static	8, 9, 10 = On
Static (Red)	1-2 = On
Static (Green)	3-4 = On
Static (Blue)	5-6 = On

Fixture Linking

In order to use this fixture in a DMX or master/slave operation, you must daisy chain, using DMX cables to link from one fixture to another.

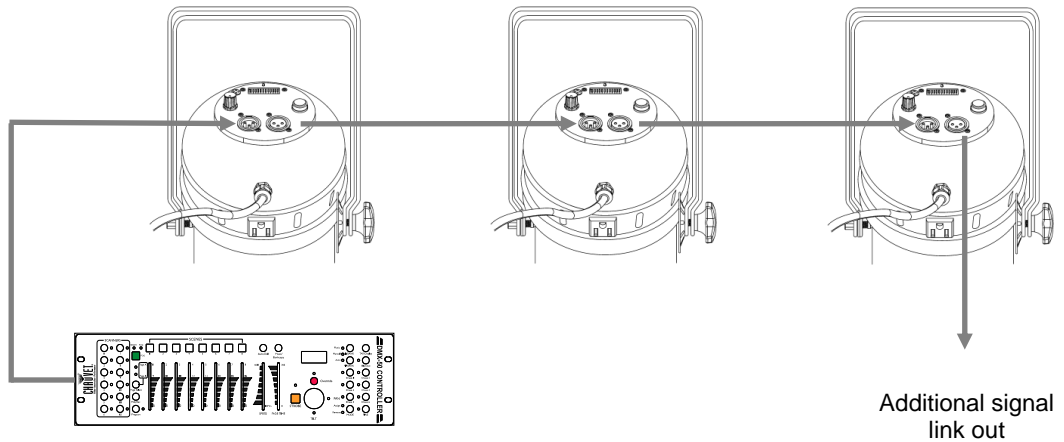

DMX Channel Values

7-CH Mode

CHANNEL	VALUE	FUNCTION
1	000 ⇄ 255	Red Dimmer: 0%~100%
2	000 ⇄ 255	Green Dimmer: 0%~100%
3	000 ⇄ 255	Blue Dimmer: 0%~100%
4	000 ⇄ 015 016 ⇄ 255	Color Macros (overrides CH.1~3) No Function Color Macros
5	000 ⇄ 255	Speed (CH.6 @ values 32~223) Slow~Fast
	000 ⇄ 015 016 ⇄ 255	Strobe (RGB & Macro only) No Function Slow~Fast
6	000 ⇄ 031 032 ⇄ 063 064 ⇄ 095 096 ⇄ 127 128 ⇄ 159 160 ⇄ 191 192 ⇄ 223 224 ⇄ 255	Mode RGB mode Pulse effect 0%~100% (using RGB faders) Pulse effect 100%~0% (using RGB faders) Pulse effect 100%~0%~100% (using RGB faders) Auto fade transition Auto snap transition (3 colors) Auto snap transition (7 colors) Sound triggering mode
		When CH.6 is set @ 032~223, CH.5 controls the speed.
7	000 ⇄ 255	Dimmer Intensity (RGB/Macro modes): 0%~100%

3-CH Mode

CHANNEL	VALUE	FUNCTION
1	000 ⇄ 255	Red Dimmer: 0%~100%
2	000 ⇄ 255	Green Dimmer: 0%~100%
3	000 ⇄ 255	Blue Dimmer: 0%~100%

Setting the Starting Address

This DMX mode enables the use of a universal DMX controller device. Each fixture requires a start address from 1–512. A fixture requiring one or more channels for control begins to read the data on the channel indicated by the start address. For example, a fixture that uses six DMX channels and was addressed to start on DMX channel 100, would read data from channels: 100, 101, 102, 103, 104, and 105. Choose start addresses so that the channels used do not overlap, and note the start address selected for future reference.

If this is your first time addressing a fixture using the DMX control protocol, we suggest jumping to the “Appendix” section and reading the heading “DMX Primer”. It contains very useful information that will help you understand its use.

General Troubleshooting

SYMPTOM	POSSIBLE CAUSE(S)	POSSIBLE ACTION(S)
Breaker/Fuse keeps blowing	<ul style="list-style-type: none"> Excessive circuit load Short circuit along the power wires 	<ul style="list-style-type: none"> Check total load placed on the electrical circuit. Check for a short in the electrical wiring (internal and/or external).
Device does not power up	<ul style="list-style-type: none"> No power Loose power cord 	<ul style="list-style-type: none"> Check for power on Mains. Check power cord
Fixture is not responding to DMX	<ul style="list-style-type: none"> Wrong DMX addressing Damaged DMX cables Wrong polarity settings on the controller Loose DMX cables Faulty DMX interface Faulty Main PCB 	<ul style="list-style-type: none"> Check Control Panel and unit addressing Check DMX cables Check polarity switch settings on the controller Check cable connections Replace DMX input Replace Main PCB
Loss of signal	<ul style="list-style-type: none"> Non DMX cables Bouncing signals Long cable / Low level signal Too many fixtures Interference from AC wires 	<ul style="list-style-type: none"> Use only DMX compatible cables Install terminator as suggested. Install amplifier right after fixture with strong signal. Install an optically coupled DMX splitter after unit #32. Keep DMX cables separated from power cables or black lights.



If you still have a problem after trying the above solutions, please contact CHAUVET Technical Support.

Contact Us

World Wide

General Information

CHAUVET
3000 North 29th Court
Hollywood, FL 33020
voice: 954.929.1115
fax: 954.929.5560
toll free: 800.762.1084

Technical Support

CHAUVET
3000 North 29th Court
Hollywood, FL 33020
voice: 954.929.1115 **(Press 4)**
fax: 954.929.5560 **(Attention: Service)**

World Wide Web

www.chauvetlighting.com

5. APPENDIX

DMX Primer

There are 512 channels in a DMX connection. Channels may be assigned in any manner. A fixture capable of receiving DMX will require one or a number of sequential channels. The user must assign a starting address on the fixture that indicates the first channel reserved in the controller. There are many different types of DMX controllable fixtures and they all may vary in the total number of channels required. Choosing a start address should be planned in advance. Channels should never overlap. If they do, this will result in erratic operation of the fixtures whose starting address is set incorrectly. You can however, control multiple fixtures of the same type using the same starting address as long as the intended result is that of unison movement or operation. In other words, the fixtures will be slaved together and all respond exactly the same.

DMX fixtures are designed to receive data through a serial Daisy Chain. A Daisy Chain connection is where the DATA OUT of one fixture connects to the DATA IN of the next fixture. The order in which the fixtures are connected is not important and has no effect on how a controller communicates to each fixture. Use an order that provides for the easiest and most direct cabling. Connect fixtures using shielded two conductor twisted pair cable with three pin XLR male to female connectors. The shield connection is pin 1, while pin 2 is Data Negative (S-) and pin 3 is Data positive (S+).

General Maintenance

To maintain optimum performance and minimize wear, fixtures should be cleaned frequently. Usage and environment are contributing factors in determining frequency. As a general rule, fixtures should be cleaned at least twice a month. Dust build up reduces light output performance and can cause overheating. This can lead to reduced lamp life and increased mechanical wear. Be sure to power off fixture before conducting maintenance.

- Unplug fixture from power.
- Use a vacuum or air compressor and a soft brush to remove dust collected on external vents.
- Clean all glass when the fixture is cold with a mild solution of glass cleaner or Isopropyl Alcohol and a soft lint free cotton cloth or lens tissue.
- Apply solution to the cloth or tissue and drag dirt and grime to the outside of the lens.
- Gently polish optical surfaces until they are free of haze and lint.

The cleaning of external optical lenses and/or mirrors must be carried out periodically to optimize light output. Cleaning frequency depends on the environment in which the fixture operates. Damp, smoky or particularly dirty surroundings can cause greater accumulation of dirt on the unit's optics. Clean with soft cloth using normal glass cleaning fluid. Clean the external optics at least every 20 days. Clean the fixture at least every 30/60 days.



Always dry the parts carefully after cleaning them.



Never spin a fan using compressed air.

Returns Procedure

Returned merchandise must be sent prepaid and in the original packing; call tags will not be issued. Package must be clearly labeled with a Return Merchandize Authorization Number (RMA #). Products returned without the RMA # will be refused. Call CHAUVET and request an RMA # prior to shipping the fixture. Be prepared to provide the model number, serial number and a brief description of the cause for the return. Be sure to pack fixture properly; any shipping damage resulting from inadequate packaging is the customer's responsibility. As a suggestion, proper UPS packing or double-boxing is always a safe method to use.

CHAUVET reserves the right to use its own discretion to repair or replace product(s).



If you are given an RMA #, please include the following information on a piece of paper inside the box:

- 1) Your name
- 2) Your address
- 3) Your phone number
- 4) The RMA #
- 5) A brief description of the symptoms

Claims

Damage incurred in shipping is the responsibility of the shipper; therefore, the damage must be reported to the carrier upon receipt of merchandise. It is the customer's responsibility to notify and submit claims with the shipper in the event that a fixture is damaged due to shipping. Any other claim for items such as missing component/part, damage not related to shipping, and concealed damage, must be made within seven (7) days of receiving merchandise.

Technical Specifications

WEIGHT & DIMENSIONS

Length..... 11.4 in (289 mm)
Width..... 11.2 in (284 mm)
Height..... 14.9 in (378 mm)
Weight..... 5.4 lbs (2.4 kg)

POWER

Autoswitching Power Supply 100~240 VAC, 50/60 Hz
Power Consumption @ 120 VAC, 60 Hz 44 W (0.6 A) max, 0.3 A inrush
Power Consumption @ 230 VAC, 50 Hz 48 W (0.3 A) max, 0.3 A inrush
Power output 10 units max
Fuse..... T 2 A, 250 V

LIGHT SOURCE

LED..... 36 1 W, 350 mA, 50,000 hrs

PHOTO OPTIC

Luminance @ 1 m 5,800 lux
Beam Angle 18°
Field Angle 36°

THERMAL

Maximum ambient temperature 104° F (40° C)

ORDERING INFORMATION

LED PAR 64-36B (Black) LEDPAR6436B
LED PAR 64-36C (Chrome) LEDPAR6436C

WARRANTY INFORMATION

Warranty 2-year limited warranty