

Q-Wash LED™

Snapshot

Ok on Dimmer	⊘
Outdoor OK	⊘
Sound Activated	✓
DMX/Master/Slave	✓
115V/230V Switch	✓
Replaceable Fuse	✓
User Serviceable	⊘
Duty Cycle	⊘

USER MANUAL

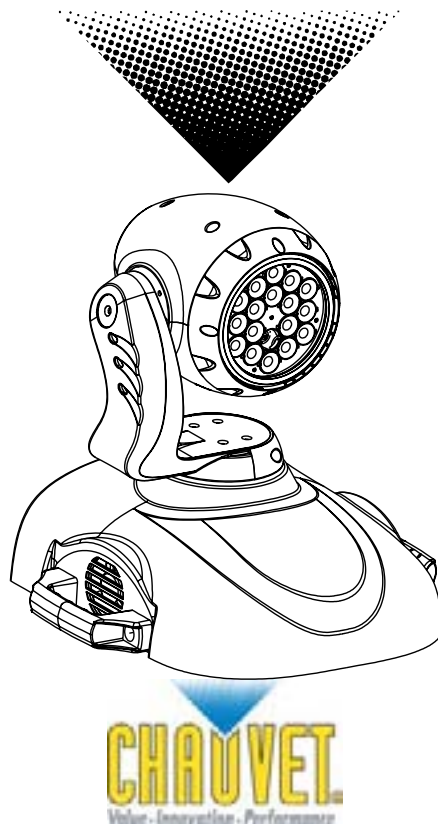

CHAUVET
Value. Innovation. Performance.

Chauvet, 3000 N 29th Ct, Hollywood, FL 33020 U.S.A
(800) 762-1084 – (954) 929-1115
FAX (954) 929-5560
www.chauvetlighting.com

TABLE OF CONTENTS

1. BEFORE YOU BEGIN.....	3
UNPACKING INSTRUCTIONS.....	3
CONTACT US	3
IMPORTANT SAFETY INFORMATION.....	4
FUSE REPLACEMENT	4
2. INTRODUCTION	5
FEATURES	5
DMX CHANNEL SUMMARY	5
PRODUCT OVERVIEW	6
3. SETUP.....	7
AC POWER	7
MOUNTING.....	7
FIXTURE LINKING.....	8
Data Cabling	8
DMX Data Cable	8
Cable Connectors	8
3-Pin to 5-Pin Conversion Chart	9
SETTING UP A DMX SERIAL DATA LINK	9
STAND-ALONE/MASTER-SLAVE	9
FIXTURE LINKING.....	9
4. OPERATING INSTRUCTIONS.....	10
NAVIGATING THE CONTROL PANEL.....	10
OPERATING MODES.....	10
Master/Stand-alone Operation.....	10
Slave Mode Operation	11
DMX Mode Operation	11
Creating Custom Programs	11
ADDITIONAL MENU OPTIONS.....	12
To set the pan to inverting or non-inverting:.....	12
To set the tilt to inverting or non-inverting:.....	12
To reset the fixture:.....	12
To restore all settings to their factory defaults:.....	12
5. APPENDIX.....	13
DMX PRIMER	13
MAINTENANCE.....	13
RETURNS PROCEDURE	14
CLAIMS	14
DMX CHANNEL VALUES	14
MENU MAP.....	15
TECHNICAL SPECIFICATIONS.....	16
TECHNICAL SUPPORT	16

1. BEFORE YOU BEGIN

Unpacking Instructions

Immediately upon receiving a product, carefully unpack the carton, check the contents to ensure that all parts are present, and have been received in good condition. Notify the shipper immediately and retain packing material for inspection if any parts appear damaged from shipping or the carton itself shows signs of mishandling. **Save the carton and all packing materials.** In the event that a fixture must be returned to the factory, it is important that the fixture be returned in the original factory box and packing.

Note: If you should require sending any items back to CHAUVET, call CHAUVET for a (RMA) Return Merchandise Authorization number. The factory will not allow any shipments without an RMA.

Your shipment includes the following:

- 1 x Q-Wash LED™
- 1 x Power cable
- Warranty Card
- Users Manual

Contact Us

World Wide

General Information

Chauvet Lighting
3000 North 29th Court
Hollywood, FL 33020
voice: 954.929.1115
fax: 954.929.5560
toll free: 800.762.1084

Technical Support

Chauvet Lighting
3000 North 29th Court
Hollywood, FL 33020
voice: 954.929.1115 **(Press 4)**
fax: 954.929.5560 **(Attention: Service)**

World Wide Web

www.chauvetlighting.com

Important Safety Information



This product is designed for professional use. It is not intended for use in a household environment. This product presents risks of lethal or severe injury due to fire and heat, electric shock, ultraviolet radiation, lamp explosion, and injury from falls. **Read this manual** before installing or powering the fixture, follow the safety precautions listed below and observe all warnings in this manual and on the fixture. If you have any questions about how to operate the fixture safely, please contact CHAUVET.

Protection against Electric Shock

- Always disconnect from AC power source before servicing or replacing lamp or fuse.
- All Class I fixtures must be connected to circuits with a suitable Earth Ground.
- To prevent risk of fire or shock, do not expose fixture to rain or moisture. Make sure there are no flammable materials close to the unit while operating.
- Make sure power cord is never crimped or damaged.
- Never disconnect power cord by pulling or tugging on the cord.

Protection against Fire & Burns

- Always make sure that you are connecting to the proper voltage and that the line voltage you are connecting to is not higher than that stated on decal or rear panel of the fixture.
- The unit must be installed in a location with adequate ventilation, at least 50cm from adjacent surfaces. Be sure that no ventilation slots are blocked.
- Maintain a minimum distance of 1 meter (3.28 feet) from combustible materials.
- Maximum ambient temperature (Ta) is: 35°C (95°F). Do not operate fixture at temperatures higher than this.

Protection against Injury to persons

- Secure fixture to fastening device using a safety chain.
- Do not open fixture for a minimum of 15 minutes after switching off.
- In the event of serious operating problem, stop using the unit immediately. Never try to repair the unit by yourself. Repairs carried out by unskilled people can lead to damage or malfunction. Please contact the nearest authorized technical assistance center. Always use the same type spare parts.

Caution! *There are no user serviceable parts inside the unit. Do not open the housing or attempt any repairs yourself. In the unlikely event your unit may require service, please contact CHAUVET.*

Fuse Replacement



Disconnect the power cord before replacing a fuse and always replace with the same type fuse.

With a flat head screwdriver wedge the fuse holder out of its housing. Remove the damaged fuse from its holder and replace with exact same type fuse. Insert the fuse holder back in its place and reconnect power.

The fuse is located inside this compartment. Remove using a flat head screwdriver.

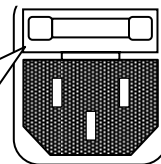

2. INTRODUCTION

Features

- 10-channel DMX-512 LED moving yoke color wash
- Pan: 540° / tilt: 270°
- RGB color mixing
- Variable electronic strobe
- Variable electronic dimmer (0 - 100%)
- Remote fixture reset and vector speed channel

Additional Features

- Extremely bright 1W LEDs
- Automatic pan & tilt correction
- 100 user-programmable steps accessible via master/slave or DMX
- Built-in automated programs via master/slave or DMX
- Built-in sound activated programs via master/slave or DMX
- Micro-stepping motors
- LCD display
- Reset to factory settings option
- Low power consumption
- Reversible pan and tilt
- Thermal switch
- Fan cooled (adjustable speeds)

DMX Channel Summary

CHANNEL	FUNCTION
1	Pan
2	Tilt
3	Vector Speed (Pan/Tilt)
4	Red
5	Green
6	Blue/Auto-Color Speed
7	Linear Color-Macros/Auto-Color
8	Dimmer
9	Strobe
10	Mode

Product Overview

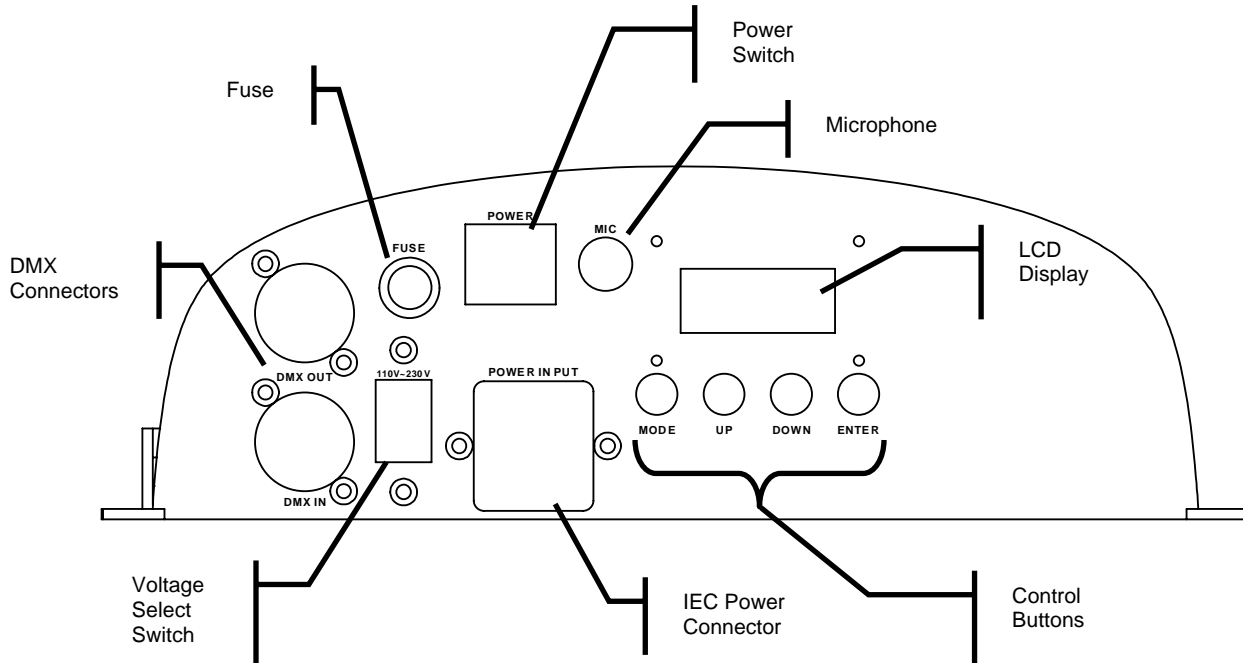
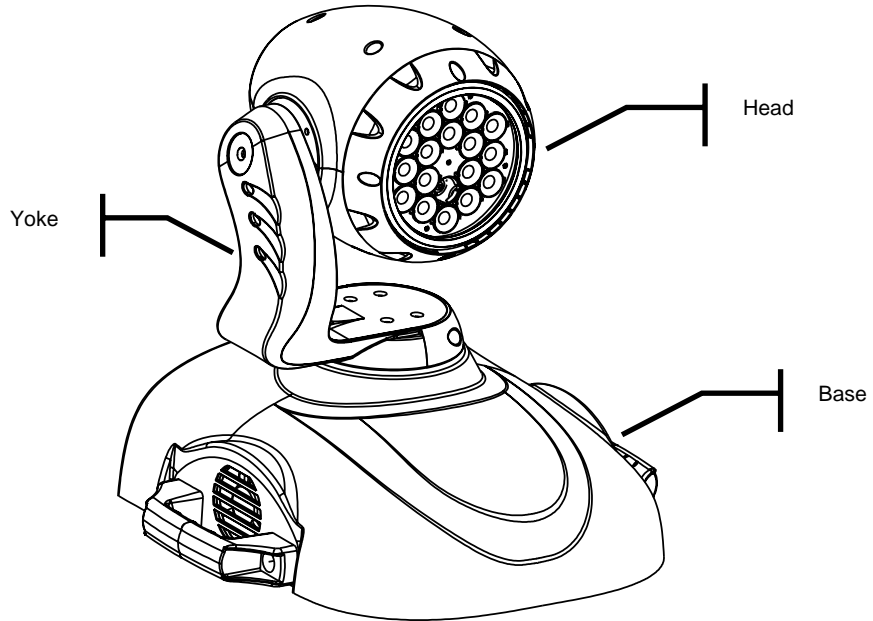

3. SETUP

AC Power

Warning!

Verify that the voltage select switch on your unit matches the line voltage applied. Damage to your fixture may result if the line voltage applied does not match the voltage indicated on the voltage selector switch. All fixtures must be connected to circuits with a suitable Earth Ground.

- To determine the power requirements for a particular fixture, see the label affixed to the back plate of the fixture or refer to the fixture's specifications chart.
- A fixture's listed current rating is its average current draw under normal conditions.
- All fixtures must be powered directly off a switched circuit and cannot be run off a rheostat (variable resistor) or dimmer circuit, even if the rheostat or dimmer channel is used solely for a 0% to 100% switch.
- Before applying power to a fixture, check that the source voltage matches the fixture's requirement, and that the fuse is the value specified for the operating voltage (110V operation = 2A 125V/250V fast blow; 230V operation = 1A 250V fast blow).
- All fixtures must be connected to circuits with a suitable Earth Ground.

Power Cable Configuration

CABLE	Pin	International	Screw Color
BROWN	Live	L	Yellow or Brass
BLUE	Neutral	N	Silver
YELLOW/GREEN	Earth	EG (Ground)	Green

Mounting

Orientation

This fixture can be mounted on a truss using a clamp in any position or against a flat surface using the brackets provided.

Rigging

The fixture includes two brackets with ¼ turn locks for attaching a standard truss mounting hanging clamp. You must supply your own clamp and make sure the clamp is capable of supporting the weight of this fixture. You can order C-clamps from any CHAUVET dealer or distributor.

1. Block access below the work area and use suitable and stable platform when installing or servicing fixture.
2. Align the clamp screw with the center hole on the yoke and tighten.
3. Verify the structure can hold 10 times the weight of all to-be installed fixtures.
4. Adjust the angle on the yoke arm as necessary.
5. Always use a safety cable or chain as a secondary source of attachment. The safety cable must hold 10 times the weight of the fixture. If safety cable attachment point is provided that is permanently affixed to the surface or body of the fixture, use that instead of looping through a hanging yoke/arm.

Hanging Clamp

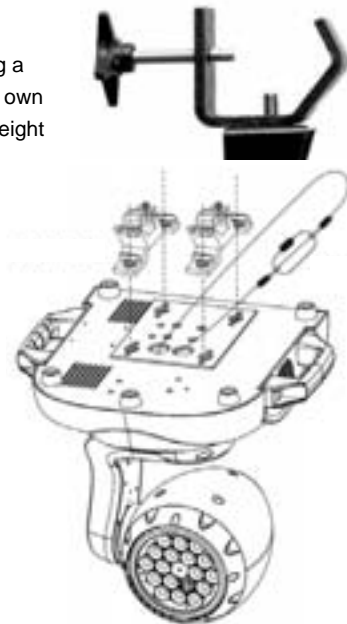

Fixture Linking

You will need a serial data link to run light shows of one or more fixtures using a DMX-512 controller or to run synchronized shows on two or more fixtures set to a master/slave operating mode. The combined number of channels required by all the fixtures on a serial data link determines the number of fixtures the data link can support.

The Q-Wash LED fixtures use 10 channels of DMX control.

Important: Fixtures on a serial data link must be daisy chained in one single line. To comply with the EIA-485 standard no more than 32 devices should be connected on one data link. Connecting more than 32 fixtures on one serial data link without the use of a DMX optically-isolated splitter may result in deterioration of the digital DMX signal.

Maximum recommended serial data link distance: 500 meters (1640 ft.)

Maximum recommended number of fixtures on a serial data link: 32 fixtures

Data Cabling

To link fixtures together you must obtain data cables. You can purchase CHAUVET-certified DMX cables directly from a dealer/distributor or construct your own cable. If you choose to create your own cable please use data-grade cables that can carry a high quality signal and are less prone to electromagnetic interference.

DMX Data Cable

Use a Belden© 9841 or equivalent cable which meets the specifications for EIA RS-485 applications. Standard microphone cables cannot transmit DMX data reliably over long distances. The cable will have the following characteristics:

*2-conductor twisted pair plus a shield
Maximum capacitance between conductors – 30 pF/ft.
Maximum capacitance between conductor and shield – 55 pF/ft.
Maximum resistance of 20Ω / 1000 ft.
Nominal impedance 100 - 140Ω*

Cable Connectors

Cabling must have a male XLR connector on one end and a female XLR connector on the other end.

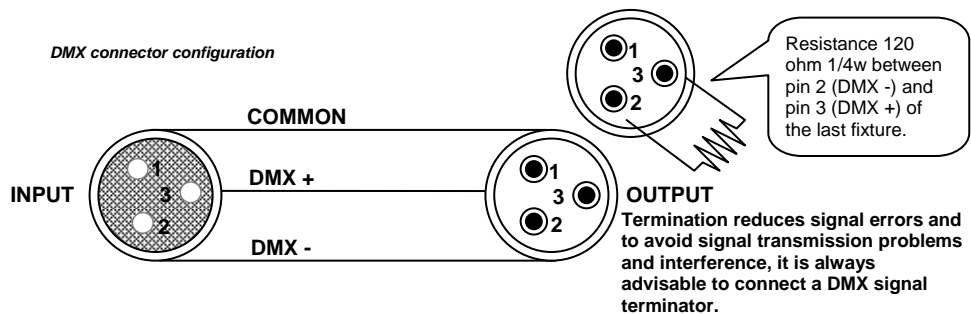

CAUTION Do not allow contact between the common and the fixture's chassis ground. Grounding the common can cause a ground loop, and your fixture may perform erratically. Test cables with an ohm meter to verify correct polarity and to make sure the pins are not grounded or shorted to the shield or each other.

3-Pin to 5-Pin Conversion Chart

Note! If you use a controller with a 5 pin DMX output connector, you will need to use a 5 pin to 3 pin adapter.
 CHAUVET Model No: DMX5M.
 The chart below details a proper cable conversion:

3 PIN TO 5 PIN CONVERSION CHART

Conductor	3 Pin Female (output)	5 Pin Male (Input)
Ground/Shield	Pin 1	Pin 1
Data (-) signal	Pin 2	Pin 2
Data (+) signal	Pin 3	Pin 3
Do not use		Do not use
Do not use		Do not use

Setting up a DMX Serial Data Link

1. Connect the (male) 3 pin connector side of the DMX cable to the output (female) 3 pin connector of the controller.
2. Connect the end of the cable coming from the controller which will have a (female) 3 pin connector to the input connector of the next fixture consisting of a (male) 3 pin connector.
3. Then, proceed to connect from the output as stated above to the input of the following fixture and so on.

CHAUVET Certified DMX Data Cables

Order Code	Description
DMX1.5	DMX Cable 1.5m/4.9ft
DMX4.5	DMX Cable 4.5m/14.8ft
DMX10	DMX Cable 10m/32.8ft

Universal DMX Controller

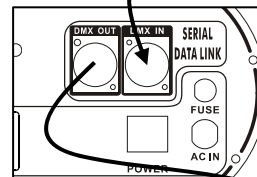
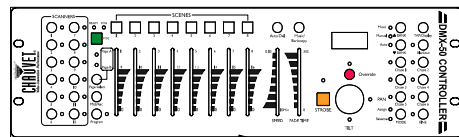

This drawing provides a general illustration of the DMX Input/Output panel of a lighting fixture.

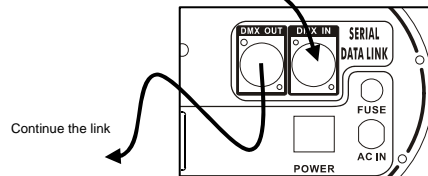

Stand-alone/Master-Slave Fixture Linking

1. Connect the (male) 3 pin connector side of the DMX cable to the output (female) 3 pin connector of the first fixture.
2. Connect the end of the cable coming from the first fixture which will have a (female) 3 pin connector to the input connector of the next fixture consisting of a (male) 3 pin connector. Then, proceed to connect from the output as stated above to the input of the following fixture and so on.

Often, the setup for Master-Slave and stand-alone operation requires that the first fixture in the chain be initialized for this purpose via either settings in the control panel or DIP-switches. Secondly, the fixtures that follow may also require a slave setting. Please consult the "Operating Instructions" section in this manual for complete instructions for this type of setup and configuration.

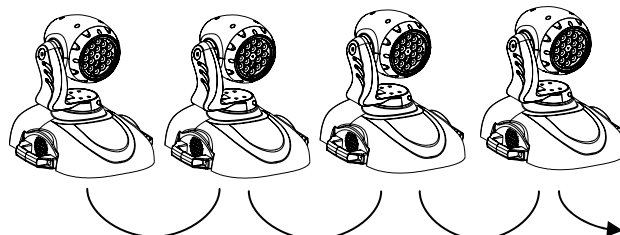

4. OPERATING INSTRUCTIONS

Navigating the Control Panel

Access control panel functions using the four panel buttons located directly underneath the LCD Display.

Button	Function
<MODE>	Used to access the menu or to return to a previous menu option
<UP>	Scrolls through menu options in ascending order
<DOWN>	Scrolls through menu options in descending order
<ENTER>	Used to select and store the current menu or option within a menu

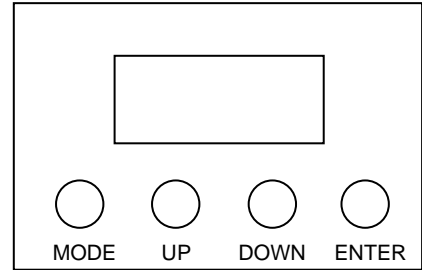

The Control Panel LED Display shows the menu items you select from the menu map on page 15. When a menu function is selected, the display will show immediately the first available option for the selected menu function. To select a menu item, press <ENTER>.

Press the <MODE> button repeatedly until *MENU* appears on the top line of the display. This is the top of the menu map. What appears on the bottom line of the display is one of the four choices in the menu map. Use the <UP> and <DOWN> buttons to navigate the menu map and menu options. Press the <ENTER> button to access the menu function currently displayed or to enable a menu option. To return to the previous option or menu without changing the value, press the <MODE> button.

Operating Modes

Master/Stand-alone Operation

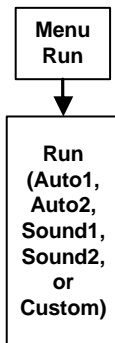

This mode allows the unit to operate either as a stand-alone unit, or as the master of one or more slave units.

- 1) In the menu, select "Run".
- 2) Scroll through and select a program. The program options are: "Auto1", "Auto2", "Sound1", "Sound2", and "Custom". Select the desired program from the available options. That program will then begin running.
- 3) For Master operation, use standard DMX cables to daisy chain your units together via the DMX connector on the rear of the units. For longer cable runs we suggest a terminator at the last fixture. For more information about terminators, see page 8.

Program	Description
Auto1	Program that runs on a predetermined time interval that is fixed.
Auto2	Program that runs on a predetermined time interval that is fixed.
Sound1	Same as "Auto1", except that each step of the program occurs when a beat is detected from the built-in microphone.
Sound2	Same as "Auto2", except that each step of the program occurs when a beat is detected from the built-in microphone.
Custom	User-programmable scene, which can be programmed by following the instructions on page 11.

Slave Mode Operation

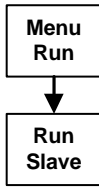

This mode allows the unit to operate as the slave of another Master unit. Up to 32 fixtures may be linked together in this mode.

- 1) In the menu, select "Run". Next, scroll through until "Slave" is displayed, and select it. Press **<MODE>** until "Run" is displayed on the second line.
- 2) Use standard DMX cables to daisy chain your units together via the DMX connector on the rear of the units. For longer cable runs we suggest a terminator at the last fixture. For more information about terminators, see page 8.

DMX Mode Operation

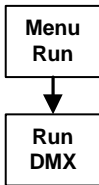

This mode allows the unit to be controlled by any universal DMX controller. If you are unfamiliar with DMX, please read the DMX Primer on page 13.

- 1) In the menu, select "Run". Next, select "DMX". Press **<MODE>** until "Run" is displayed on the second line.
- 2) Scroll through until "Address" is displayed, and select it. Use the **<UP>** and **<DOWN>** buttons to input the desired DMX starting address. Press **<ENTER>** to set the DMX starting address.
- 3) Use standard DMX cables to daisy chain your units together via the DMX connector on the rear of the units. For longer cable runs we suggest a terminator at the last fixture. For more information about terminators, see page 8.

Creating Custom Programs

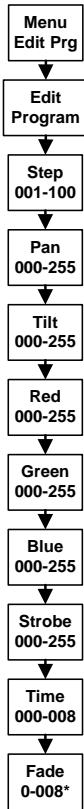

In order to create a custom program than can be run in any mode, do the following:

- 1) In the menu, select "Edit Prg". Next, scroll through until "Edit Program" is displayed, and select it.
- 2) Scroll through to the step you wish to program, and select it.

Note: The program runs in sequential order, starting with step 001, and continuing through the last step that was programmed. It is therefore not necessary to program all 100 steps. In other words, if only steps 001, 002, and 003 are programmed, the routine will start again at step 001 after step 003 has finished executing.

- 3) "Pan" will be displayed on the top line of the screen. Scroll through to the pan value you wish to program, and select it. Repeat this for the "Tilt", "Red", "Green", "Blue", "Strobe", "Time", and "Fade" values. Note that "Time" is the length of time in seconds that the current step will run, and must be a value between 0 and 8. Also note that the value of "Fade" cannot be larger than the value of "Time". "Fade" is the amount of time, in seconds, that the fixture will take to gradually transition between the previous step and the current step. If the value of "Fade" is 0, the transition will be at the maximum speed possible.
- 4) Repeat steps 2 and 3 until the program is created. To end programming, press **<MODE>** until "Menu" is displayed.
- 5) To reset (erase) the custom program, select "Edit Prg" from the menu. Scroll through to "Reset Custom" and select it; "Confirm Reset" will be displayed. Press **<ENTER>** to reset the fixture.

The program can be run in any mode. See the above instructions for the desired operating mode in order to run the custom program.

***Note:** Fade value cannot exceed time value. For example, if time is set to 4, fade can be 0-4.

Additional Menu Options

This fixture can be customized in several different ways at the discretion of the user. This section details how to change the fan speed, invert the Pan, invert the Tilt, reset the fixture, and restore the fixture to factory default settings.

To change the fan speed:

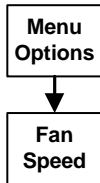

- 1) In the menu, select "Options". Scroll through to "Fan Speed", and select it.
- 2) Scroll to the desired speed, either "Low" or "High", and select it.

To set the pan to inverting or non-inverting:

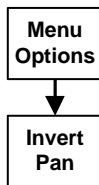

- 1) In the menu, select "Options". Scroll through to "Invert Pan" and select it.
- 2) Scroll to "Pan On" or "Pan Off" and select the desired setting. Note that "Pan On" inverts the pan values, and "Pan Off" uses the standard pan values.

To set the tilt to inverting or non-inverting:

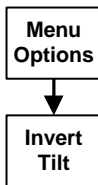

- 1) In the menu, select "Options". Scroll through to "Invert Tilt" and select it.
- 2) Scroll to "Tilt On" or "Tilt Off" and select the desired setting. Note that "Tilt On" inverts the tilt values, and "Tilt Off" uses the standard tilt values.

To reset the fixture:

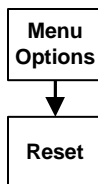

- 1) In the menu, select "Options". Scroll through to "Reset" and select it. The fixture will then reset itself.

To restore all settings to their factory defaults:

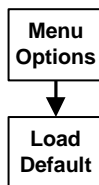

- 1) In the menu, select "Options." Scroll through to "Load Default" and select it. This will restore all settings to their factory defaults.

5. APPENDIX

DMX Primer

There are 512 channels in a DMX-512 connection, though all 512 channels do not need to be used. Channels may be assigned in any manner. A fixture capable of receiving DMX-512 will require one or a number of sequential channels. The user must assign a starting address on the fixture that indicates the first channel reserved in the controller. There are many different types of DMX controllable fixtures and they all may vary in the total number of channels required. Choosing a start address should be planned in advance. Channels should never overlap. If they do, this will result in erratic operation of the fixtures whose starting address is set incorrectly. You can however, control multiple fixtures of the same type using the same starting address as long as the intended result is that of unison movement or operation. In other words, the fixtures will be slaved together and all respond exactly the same.

DMX fixtures are designed to receive data through a serial Daisy Chain. A Daisy Chain connection is where the DATA OUT of one fixture connects to the DATA IN of the next fixture. The order in which the fixtures are connected is not important and has no effect on how a controller communicates to each fixture. Use an order that provides for the easiest and most direct cabling. Connect fixtures using shielded two conductor twisted pair cable with three pin XLR male to female connectors. The shield connection is pin 1, while pin 2 is Data Negative (S-) and pin 3 is Data positive (S+). CHAUVET carries 3-pin DMX-compliant cables, DMX-10 (33'), DMX-4.5 (15') and DMX-1.5 (5'). Contact the nearest Chauvet dealer to order any of these cables.

Maintenance

To maintain optimum performance and minimize wear, fixtures should be cleaned frequently. Usage and environment are contributing factors in determining frequency. As a general rule, fixtures should be cleaned at least twice a month. Dust build up reduces light output performance and can cause overheating. This can lead to reduced lamp life and increased mechanical wear. Be sure to power off fixture before conducting maintenance.

Unplug fixture from power. Use a vacuum or air compressor and a soft brush to remove dust collected on external vents and internal components. Clean all glass when the fixture is cold with a mild solution of glass cleaner or Isopropyl Alcohol and a soft lint-free cotton cloth or lens tissue. Apply solution to the cloth or tissue and drag dirt and grime to the outside of the lens. Gently polish optical surfaces until they are free of haze and lint. Do not touch the lamp glass when cleaning fixture. Oil and dirt can cause damage and premature aging of the lamp. In the event that the lamp is touched or becomes dirty, clean the lamps with an alcohol wipe.

The cleaning of internal and external optical lenses and/or mirrors must be carried out periodically to optimize light output. Cleaning frequency depends on the environment in which the fixture operates: damp, smoky or particularly dirty surrounding can cause greater accumulation of dirt on the unit's optics. Clean with soft cloth using normal glass cleaning fluid. - Always dry the parts carefully. - Clean the external optics at least every 20 days. Clean the internal optics at least every 30/60 days.

Returns Procedure

Returned merchandise must be sent prepaid and in the original packing, call tags will not be issued. Package must be clearly labeled with a Return Merchandise Authorization Number (RA #). Products returned without an RA # will be refused. Call CHAUVET and request an RA # prior to shipping the fixture. Be prepared to provide the model number, serial number and a brief description of the cause for the return. Be sure to properly pack fixture, any shipping damage resulting from inadequate packaging is the customer's responsibility. CHAUVET reserves the right to use its own discretion to repair or replace product(s). As a suggestion, proper UPS packing or double-boxing is always a safe method to use.

Claims

Damage incurred in shipping is the responsibility of the shipper; therefore the damage must be reported to the carrier upon receipt of merchandise. It is the customer's responsibility to notify and submit claims with the shipper in the event that a fixture is damaged due to shipping. Any other claim for items such as missing component/part, damage not related to shipping, and concealed damage, must be made within seven (7) days of receiving merchandise.

DMX Channel Values

CHANNEL	VALUE	FUNCTION
1	000 ⇔ 255	Pan: 128 = halfway point
2	000 ⇔ 255	Tilt: 128 = halfway point
3	000 ⇔ 255	Vector Speed (Pan/Tilt): (Normal > Slow)
4	000 ⇔ 255	Red (0 – 100%)
5	000 ⇔ 255	Green (0 – 100%)
6	000 ⇔ 255	Blue (0 – 100%) Auto-color speed when CH7 = 241-255
7	000 ⇔ 005	No function
	006 ⇔ 035	Red: 100%, Green varies: 0 – 100%
	036 ⇔ 065	Red varies: 100 – 0%, Green: 100%
	066 ⇔ 095	Green: 100%, Blue varies: 0 – 100%
	096 ⇔ 125	Green varies: 100 – 0%, Blue: 100%
	126 ⇔ 155	Red varies: 0 – 100%, Blue: 100%
	156 ⇔ 185	Red: 100%, Blue varies: 100 – 0%
	186 ⇔ 215	Red: 100%, Green varies: 0 – 100%, Blue varies: 0 – 100%
	216 ⇔ 240	Red varies: 100 – 50%, Green varies: 100 – 50%, Blue varies: 100 – 50%
	241 ⇔ 250	Auto-color
251 ⇔ 255	White	
8	000 ⇔ 255	Dimmer (0 – 100%)
9	000 ⇔ 005	No function
	006 ⇔ 255	Strobe (Slow > Fast)
10	000 ⇔ 045	No function
	046 ⇔ 055	Reset (after 3 seconds)
	056 ⇔ 095	Auto1 (after 3 seconds)
	096 ⇔ 135	Auto2 (after 3 seconds)
	136 ⇔ 175	Sound1 (after 3 seconds)
	176 ⇔ 215	Sound2 (after 3 seconds)
	216 ⇔ 255	Custom (after 3 seconds)

Menu Map

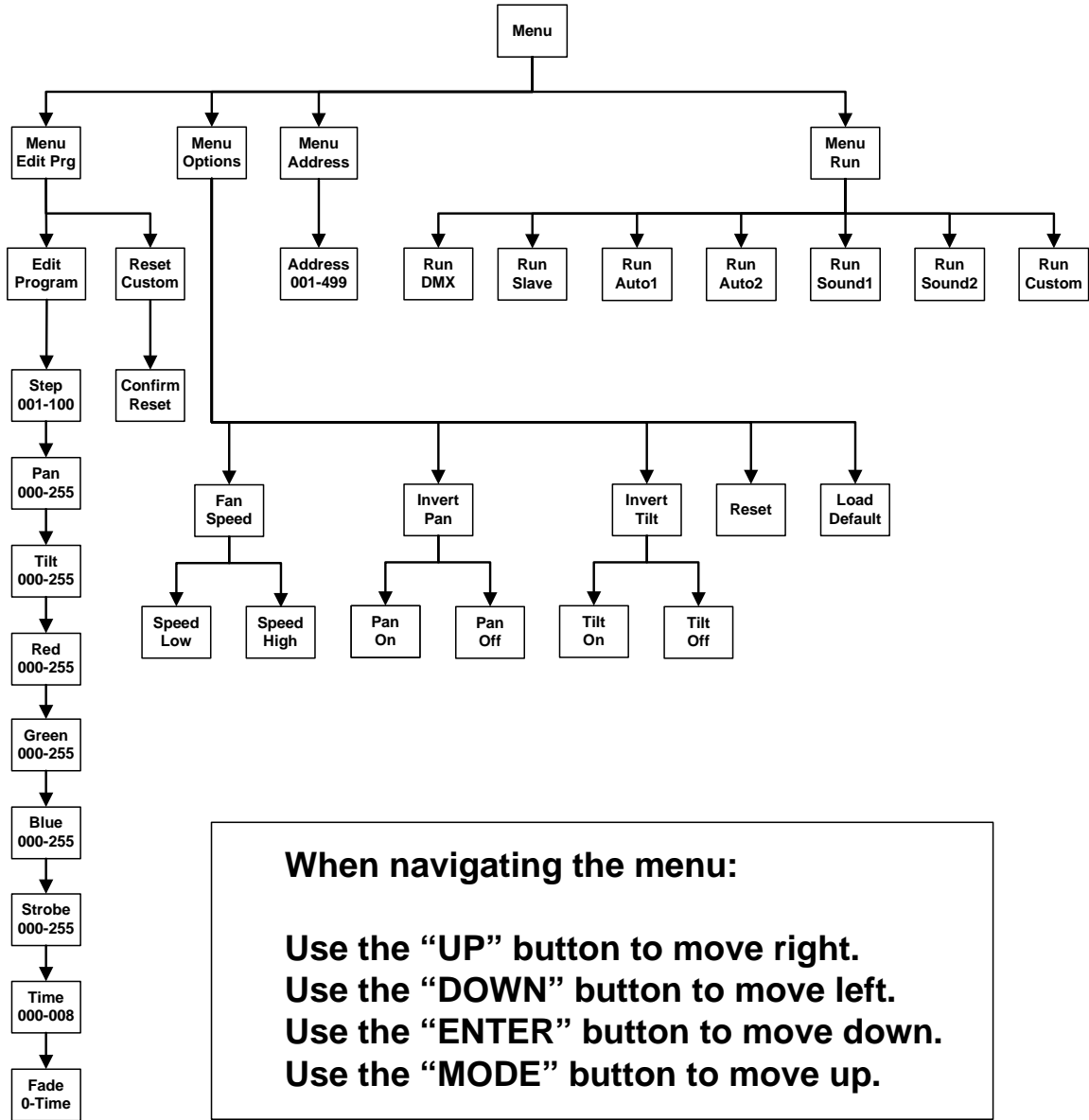

When navigating the menu:

- Use the “UP” button to move right.**
- Use the “DOWN” button to move left.**
- Use the “ENTER” button to move down.**
- Use the “MODE” button to move up.**

Technical Specifications

WEIGHT & DIMENSIONS

Length.....	14.0 in (356 mm)
Width	11.8 in (300 mm)
Height.....	14.0 in (356 mm)
Weight	19.6 lbs (8.9 kg)

POWER

Operating Voltage	110V 50/60 Hz or 230V 50/60 Hz
AC input plug.....	IEC 60320 C14
Power consumption.....	50W
Inrush.....	216W

PHOTO OPTIC

Beam angle with included 15° lenses.....	30°
Beam angle with optional 30° lenses	45°
Pan	540°
Tilt.....	270°
Illuminance	(406fc or 4369lux) @ 1 meter

LAMPS

Bulb	18 (6 red, 6 green, 6 blue) 1W LED's, 100,000 hrs
------------	---

FUSE

110V Operation	2A 125V fast blow or 2A 250V fast blow
230V Operation	1A 250V fast blow

CONTROL & PROGRAMMING

Data input	locking 3-pin XLR male socket
Data output	locking 3-pin XLR female socket
Data pin configuration	pin 1 shield, pin 2 (-), pin 3 (+)
Protocols.....	DMX-512 USITT
DMX Channels	10

ORDERING INFORMATION

Q-Wash LED™	Q-WASH LED
-------------------	------------

WARRANTY INFORMATION

Warranty	2-year limited warranty
----------------	-------------------------

Technical Support

Address: Service Dept.
3000 N 29th Ct, Hollywood, FL 33020 (U.S.A.)
Support (Email): tech@chauvetlighting.com
Telephone: (954) 929-1115 - (Press 4)
Fax: (954) 929-5560 - (Attention: Service)
Website: <http://www.chauvetlighting.com>