

SX Scope™

Snapshot

Ok on Dimmer	⊘
Outdoor OK	⊘
Sound Activated	✓
DMX512	⊘
Master/Slave	⊘
115V/230V Switch	⊘
Replaceable Fuse	✓
User Serviceable	⊘
Duty Cycle	✓

USER MANUAL

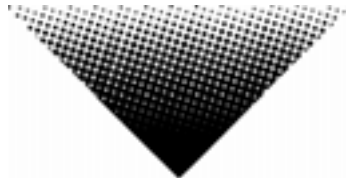

Chauvet, 3000 N 29th Ct, Hollywood, FL 33020 U.S.A.
(800) 762-1084 – (954) 929-1115
FAX (954) 929-5560
www.chauvetlighting.com

TABLE OF CONTENTS

1. BEFORE YOU BEGIN	3
WHAT IS INCLUDED.....	3
UNPACKING INSTRUCTIONS.....	3
AC POWER.....	3
CONTACT US.....	3
SAFETY INSTRUCTIONS.....	4
Duty Cycle.....	4
2. INTRODUCTION	5
FEATURES.....	5
PRODUCT OVERVIEW	5
3. SETUP	6
LAMP.....	6
Lamp Installation.....	6
FUSE REPLACEMENT.....	7
MOUNTING	7
Orientation	7
Rigging	7
4. OPERATING INSTRUCTIONS	7
GENERAL TROUBLESHOOTING.....	8
TECHNICAL SUPPORT	9
5. APPENDIX	9
GENERAL MAINTENANCE	9
RETURNS PROCEDURE.....	9
CLAIMS.....	10
TECHNICAL SPECIFICATIONS	10

1. BEFORE YOU BEGIN

What is included

- 1 x SX Scope™
- ELC3 24V 250W Lamp
- Warranty Card
- User Manual

Unpacking Instructions

Immediately upon receiving a fixture, carefully unpack the carton, check the contents to ensure that all parts are present, and have been received in good condition. Notify the shipper immediately and retain packing material for inspection if any parts appear damaged from shipping or the carton itself shows signs of mishandling. Save the carton and all packing materials. In the event that a fixture must be returned to the factory, it is important that the fixture be returned in the original factory box and packing.

AC Power

To determine the power requirements for a particular fixture, see the label affixed to the back plate of the fixture or refer to the fixture's specifications chart. A fixture's listed current rating is its average current draw under normal conditions. All fixtures must be powered directly off a switched circuit and cannot be run off a rheostat (variable resistor) or dimmer circuit, even if the rheostat or dimmer channel is used solely for a 0% to 100% switch. Before applying power to a fixture, check that the source voltage matches the fixture's requirement.

Warning! *Verify that the voltage required by your unit matches the line voltage applied. Damage to your fixture may result if the line voltage applied does not match the voltage required by the fixture. All fixtures must be connected to circuits with a suitable Earth Ground.*

Contact Us

World Wide

General Information Chauvet Lighting
3000 North 29th Court
Hollywood, FL 33020
voice: 954.929.1115
fax: 954.929.5560
toll free: 800.762.1084

Technical Support Chauvet Lighting
3000 North 29th Court
Hollywood, FL 33020
voice: 954.929.1115 **(Press 4)**
fax: 954.929.5560 **(Attention: Service)**

World Wide Web www.chauvetlighting.com

Safety Instructions



Please read these instructions carefully, which includes important information about the installation, usage and maintenance of this product.

- Please keep this User Guide for future consultation. If you sell the unit to another user, be sure that they also receive this instruction booklet.
- Always make sure that you are connecting to the proper voltage, and that the line voltage you are connecting to is not higher than that stated on the decal or rear panel of the fixture.
- This product is intended for indoor use only!
- To prevent risk of fire or shock, do not expose fixture to rain or moisture. Make sure there are no flammable materials close to the unit while operating.
- The unit must be installed in a location with adequate ventilation, at least 20 inches (50cm) from adjacent surfaces. Be sure that no ventilation slots are blocked.
- Always disconnect from power source before servicing or replacing lamp or fuse and be sure to replace with same lamp source.
- Secure fixture to fastening device using a safety chain. Never carry the fixture solely by its head. Use its carrying handles.
- Maximum ambient temperature (Ta) is 95°F (35°C). Do not operate fixture at temperatures higher than this.
- In the event of a serious operating problem, stop using the unit immediately. Never try to repair the unit by yourself. Repairs carried out by unskilled people can lead to damage or malfunction. Please contact the nearest authorized technical assistance center. Always use the same type spare parts.
- Don't connect the device to a dimmer pack.
- Make sure the power cord is never crimped or damaged.
- Avoid direct eye exposure to the lamp while it is on.

Caution! *There are no user serviceable parts inside the unit. Do not open the housing or attempt any repairs yourself. In the unlikely event your unit may require service, please contact CHAUVET at: 954-929-1115.*

Duty Cycle

This fixture has a 15/15 duty cycle, meaning it can be run for fifteen minutes, and then must be left off for 15 minutes before it is turned on again.

2. INTRODUCTION

Features

- High-tech kaleidoscope effect
- Combined color/gobo wheel:
 - 10 gobos
 - 5 colors
- Dual rotary knobs:
 - Speed of prism
 - Sound sensitivity
- Electronic transformer
- Fan cooled

Product Overview

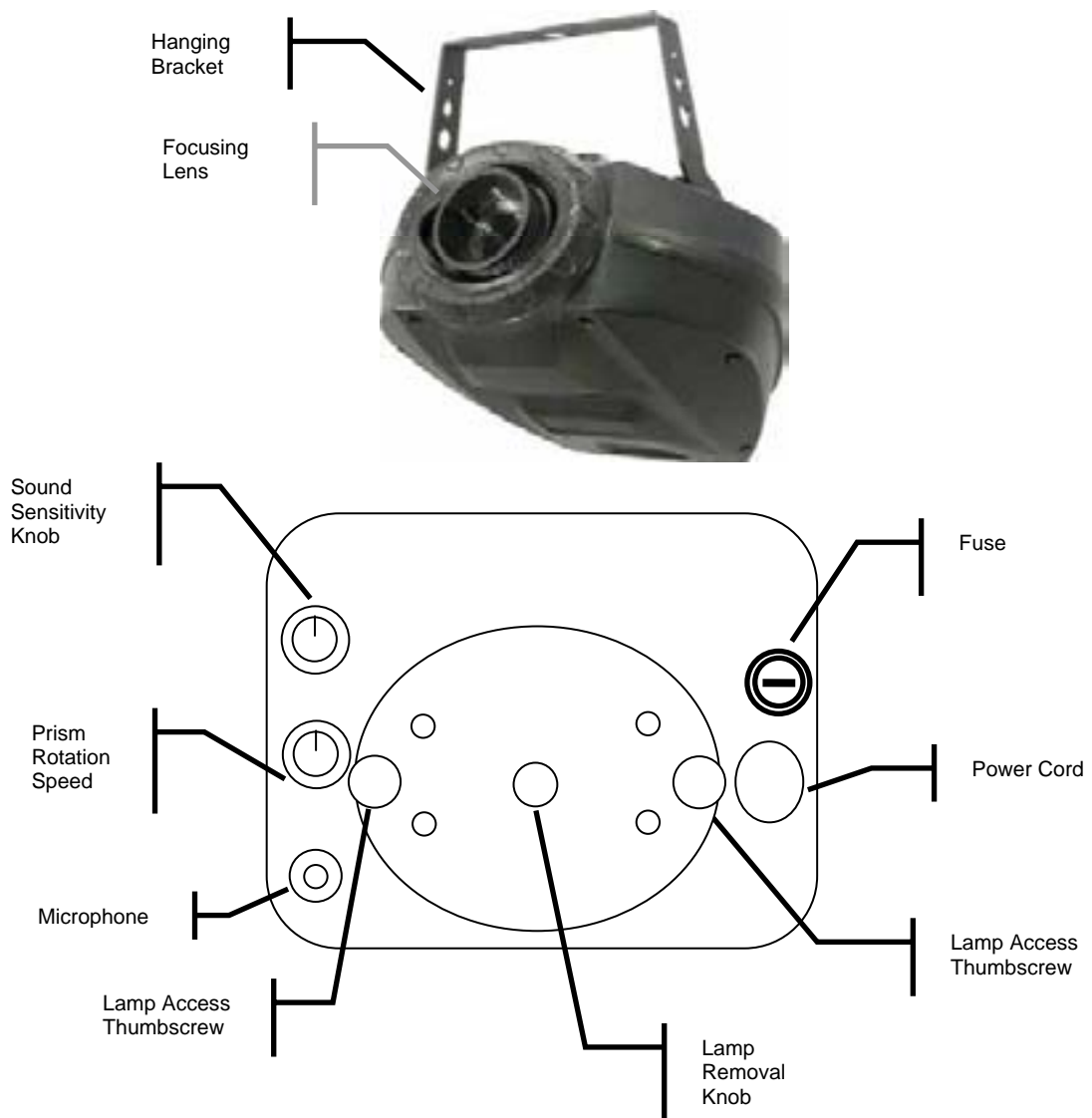

3. SETUP

Lamp

You will need to install a lamp prior to the initial operation of the fixture. A 250W lamp is included.

Warning! *When replacing the lamp, please wait 15 minutes after powering down to allow the unit to cool down! Always disconnect from main power prior to lamp replacement.*

Do not touch the envelope (glass area) of the bulb with bare hands. If this happens, clean the lamp with alcohol and wipe it with a lint-free cloth before installation.

Lamp Installation

- 1) Unscrew the two thumbscrews (Figure A).
- 2) Hold the lamp removal knob and pull the lamp housing directly out (Figure B).
- 3) Slide the lamp up past the spring clips to remove it. (Figure C).
- 4) Remove the lamp from the socket (Figure C)
- 5) Hold the new lamp with a lint-free cloth. Insert lamp into socket.
- 6) Slide the lamp down past the springs until it stops.
- 7) Insert lamp housing into the fixture.
- 8) Tighten both thumbscrews

Figure A

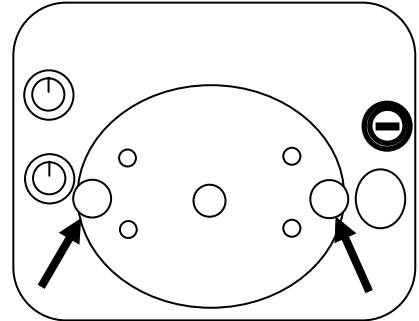

Figure B



Figure C





Disconnect the power cord before replacing a fuse and always replace with the same type fuse.



Fuse Replacement

With a flat-head screwdriver, unscrew the fuse holder from its housing. Remove the damaged fuse from its holder and replace with exact same type fuse. Screw the fuse holder back in its place and reconnect power.

The fuse is located inside this compartment. Remove using a flat head screwdriver.



FUSE

Mounting

ORIENTATION

This fixture may be mounted in any position provided there is adequate room for ventilation.

RIGGING

It is important never to obstruct the fan or vents pathway. Mount the fixture using a suitable "C" or "O" type clamp. Adjust the angle of the fixture by loosening both knobs and tilting the fixture. After finding the desired position, retighten both knobs.

- When selecting installation location, take into consideration lamp replacement access and routine maintenance.
- Safety cables should always be used.
- Never mount in places where the fixture will be exposed to rain, high humidity, extreme temperature changes or restricted ventilation.

Hanging Clamp



Note!
Clamp is sold separately.

4. OPERATING INSTRUCTIONS

- 1) Use the sound sensitivity knob to adjust the sensitivity of the unit to sound (turning the knob clockwise increases the sensitivity; counter-clockwise decreases sensitivity).
- 2) Use the prism rotation speed knob to adjust the speed of rotation (turning the knob clockwise increases rotation speed; counter-clockwise decreases the sensitivity).
- 3) Turn the focusing lens to focus the beam onto your projection surface.

General Troubleshooting

Symptom	Solution(s)	Applies to			
		Lights	Foggers & Snow	Controllers	Dimmers & Chaser
Auto shut off	Check fan thermal switch reset	✓			
Beam is very dim or not bright	Clean optical system or replace lamp Check 220/110v switch for proper setting	✓			
Breaker/Fuse keeps blowing	Check total load placed on device				✓
Chase is too slow	Check users manual for speed adjustment	✓		✓	✓
Device has no power	Check for power on Mains. Check device's fuse. (internal and/or external)	✓		✓	✓
Fixture is not responding	Check DMX Dip switch settings for correct addressing Check DMX cables Check polarity switch settings	✓			
Fixture is on but there is no movement to the audio	Make sure you have the correct audio mode on the control switches. If audio provided via ¼" jack, make sure a live audio signal exists Adjust sound sensitivity knob	✓		✓	✓
Lamps cuts off sporadically	Possible bad lamp or fixture is overheating. Lamp may be at end of its life.	✓			
Light will not come on after power failure	Some discharge lamps require a cooling off period before the electronics in the fixture can kick start it again, wait 5 to 10 minutes before powering up	✓			
Loss of signal	Use only DMX cables Install terminator Note: Keep DMX cables separated from power cables or black lights.	✓	✓	✓	✓
Moves slow	Check 220/110v switch for proper setting	✓			
No flash	Re-install bulb, may have shifted in shipping	✓			
No laser output	Bounce mirror motor may have shifted during shipping, readjust	✓			
No light output	Check slip ring & brushes for contact Install bulb Call service technician	✓			
Relay will not work	Check reset switch Check cable connections				✓
Remote does not work	Make sure connector is firmly connected to device	✓	✓		
Stand alone mode	All Chauvet lighting fixtures featuring stand-alone functions do not require additional settings, simply power the fixture and it will automatically enter into this mode	✓			

If you still have a problem after trying the above solutions, please contact CHAUVET Technical Support at the location on the next page.

Technical Support

Address: Service Dept.
3000 N 29th Ct, Hollywood, FL 33020 (U.S.A.)
Support (Email): tech@chauvetlighting.com
Telephone: (954) 929-1115 - (Press 4)
Fax: (954) 929-5560 - (Attention: Service)
Website: <http://www.chauvetlighting.com>

5. APPENDIX

General Maintenance

To maintain optimum performance and minimize wear fixtures should be cleaned frequently. Usage and environment are contributing factors in determining frequency. As a general rule, fixtures should be cleaned at least twice a month. Dust build up reduces light output performance and can cause overheating. This can lead to reduced lamp life and increased mechanical wear. Be sure to power off fixture before conducting maintenance.

Unplug fixture from power. Use a vacuum or air compressor and a soft brush to remove dust collected on external vents and internal components. Clean all glass when the fixture is cold with a mild solution of glass cleaner or Isopropyl Alcohol and a soft lint free cotton cloth or lens tissue. Apply solution to the cloth or tissue and drag dirt and grime to the outside of the lens. Gently polish optical surfaces until they are free of haze and lint.

The cleaning of internal and external optical lenses and/or mirrors must be carried out periodically to optimize light output. Cleaning frequency depends on the environment in which the fixture operates: damp, smoky or particularly dirty surrounding can cause greater accumulation of dirt on the unit's optics. Clean with soft cloth using normal glass cleaning fluid. - Always dry the parts carefully. - Clean the external optics at least every 20 days. Clean the internal optics at least every 30/60 days.

Returns Procedure

Returned merchandise must be sent prepaid and in the original packing, call tags will not be issued. Package must be clearly labeled with a Return Merchandise Authorization Number (RA #). Products returned without an RA # will be refused. Call CHAUVET and request RA # prior to shipping the fixture. Be prepared to provide the model number, serial number and a brief description of the cause for the return. Be sure to properly pack fixture, any shipping damage resulting from inadequate packaging is the customer's responsibility. CHAUVET reserves the right to use its own discretion to repair or replace product(s). As a suggestion, proper UPS packing or double-boxing is always a safe method to use.

Note: If you are given an RA #, please include the following information on a piece of paper inside the box:

- 1) Your name
- 2) Your address
- 3) Your phone number
- 4) The RA #
- 5) A brief description of the symptoms

Claims

Damage incurred in shipping is the responsibility of the shipper; therefore the damage must be reported to the carrier upon receipt of merchandise. It is the customer's responsibility to notify and submit claims with the shipper in the event that a fixture is damaged due to shipping. Any other claim for items such as missing component/part, damage not related to shipping, and concealed damage, must be made within seven (7) days of receiving merchandise.

Technical Specifications

WEIGHT & DIMENSIONS

Length..... 13 in (330 mm)
Width 12.5 in (318 mm)
Height 7 in (178 mm)
Weight 7.4 lbs (3.4 kg)

POWER

Fixed power settings (not selectable)..... 120V 60Hz AC or 230V 50Hz
Fuse..... 6.3A 250V
Power Consumption276W Max
Inrush Power 348W

LIGHT SOURCE

Lamp..... ELC3 24V 250W Lamp

PHOTO OPTIC

Beam Angle 28.5°

THERMAL

Maximum ambient temperature.....95°F (35°C)

ORDERING INFORMATION

SX Scope..... SX-SCOPE

WARRANTY INFORMATION

Warranty 1-year limited warranty