

# YPOC<sup>PRO</sup><sub>575</sub>

## Instruction Manual



from software version 1.0  
(instruction version 1.0)



**GERMAN LIGHT  
PRODUCTS**

e-mail: [service@glp.de](mailto:service@glp.de)  
Internet: <http://www.GLP.de>

This side is intentionally unlabelled.

## Table of contents

<b>1</b>	<b>Description of Device .....</b>	<b>5</b>
1.1	Safety Instructions.....	6
<b>2</b>	<b>Preparation and Installation .....</b>	<b>7</b>
2.1	Mounting .....	7
2.1.1	<i>Clamps</i> .....	7
2.2	Secure the YPOC 575 PRO .....	8
2.3	Connections .....	9
2.3.1	<i>Power supply</i> .....	9
2.3.2	<i>DMX</i> .....	9
2.4	Fuse .....	9
<b>3</b>	<b>The Menu Field .....</b>	<b>10</b>
3.1	Adjust the DMX- Address (D001).....	11
3.2	The Test Program (TEST).....	11
3.3	The Audio Program (AUDI).....	11
3.4	Lamp On/Off (LAMP) .....	12
3.5	Reset (RESE) .....	12
3.6	Running time of lamp and unit (TIME) .....	12
3.7	Invert Pan Movement (RPAN).....	12
3.8	Invert Tilt Movement (RTL T) .....	13
3.9	Special Functions (SPEC) .....	13
3.9.1	<i>Manual Drive (MANU)</i> .....	13
3.9.2	<i>Lamp On automatically (LAAU)</i> .....	13
3.9.3	<i>Lamp Off via DMX (DLOF)</i> .....	14
3.9.4	<i>DMX Input (DMXI)</i> .....	14
3.9.5	<i>Display (DISP)</i> .....	15
3.9.6	<i>Fixture Temperature (TEMP)</i> .....	15
3.9.7	<i>Fan Control (FANS)</i> .....	15
3.9.8	<i>Adjustments and Calibrations (ADJU)</i> .....	16
3.9.9	<i>Default Settings (DFSE)</i> .....	16
3.9.10	<i>Feedback (FEED)</i> .....	17
3.9.11	<i>Correction of faults (EFLG)</i> .....	17
3.10	Error and Information Messages.....	17
<b>4</b>	<b>DMX Channel Selection (DMX Protocol).....</b>	<b>18</b>
<b>5</b>	<b>Change the Lamp.....</b>	<b>22</b>

---

5.1	Safety Regulations .....	22
5.2	Realize the Lamp Change .....	22
<b>6</b>	<b>Change a Gobo .....</b>	<b>23</b>
6.1	Safety Regulations .....	23
6.2	Realize the Gobo Change .....	23
<b>7</b>	<b>Maintenance and Cleaning the YPOC 575 PRO .....</b>	<b>24</b>
7.1	Safety Regulations .....	25
7.2	Circumference and Interval (rule-of-thumb).....	25
7.3	Cleaning the Optical System .....	25
<b>8</b>	<b>Technical Specification .....</b>	<b>26</b>
<b>9</b>	<b>Index .....</b>	<b>27</b>

# 1 Description of Device

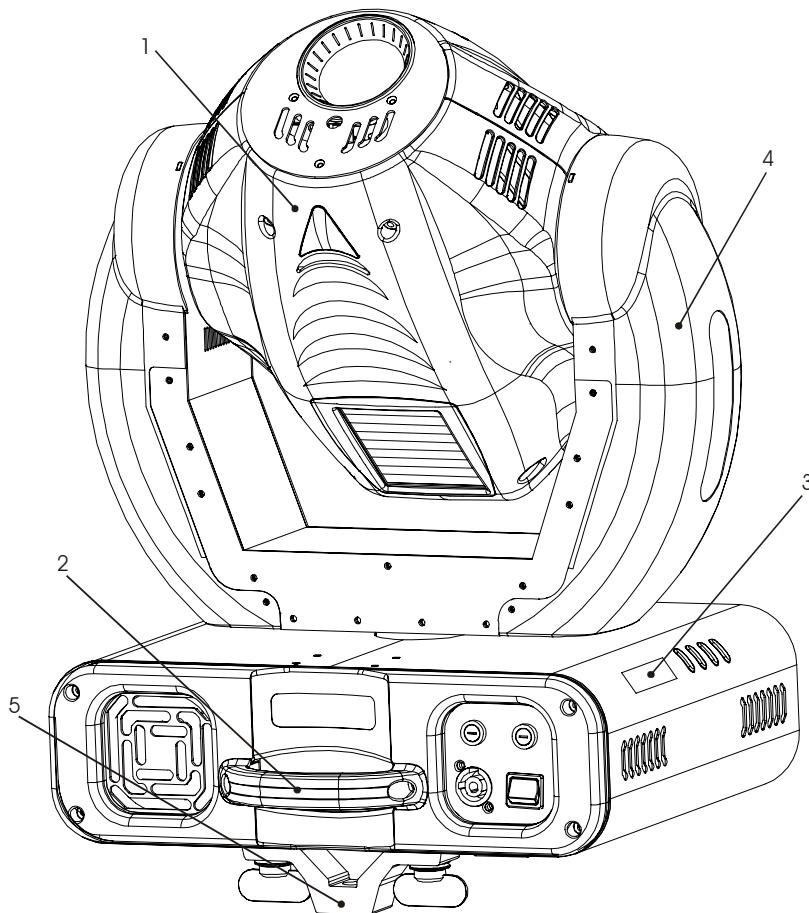

- 1. Moving Head
- 2. Carrying handles
- 3. LED- Display
- 4. Arm
- 5. Camlock system

- 6. Software-Update connector
- 7. Microphone- Intensity
- 8. DMX- Input
- 9. DMX- Output
- 10. Fan (air inlet/outlet)
- 11. Power On/Off
- 12. Mains supply (Powercon)
- 13. Fuse lamp
- 14. Fuse electronics
- 15. Carrying handles

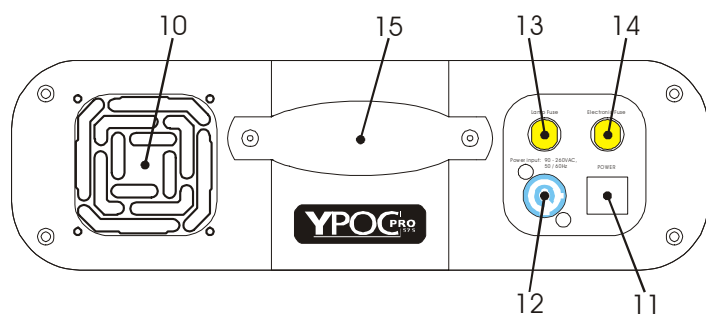
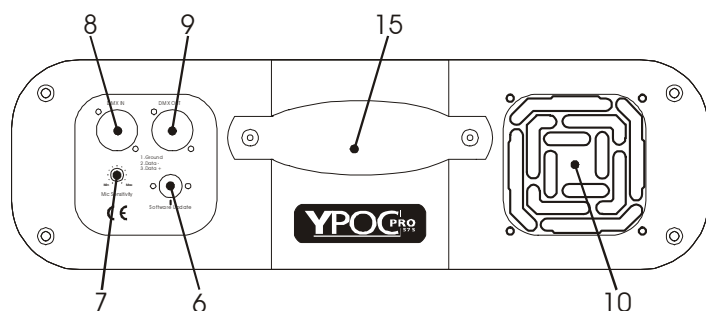

## 1.1 Safety Instructions



The **YPOC 575 PRO** is a High-Tech Product. To guarantee a smooth operation, it is necessary to keep following rules. The manufacturer of this device will not take responsibility of damages through disregard of the information in this manual. Warranty adjustments will be cancelled.

1. Make sure before putting into operation, that the fan and the air inlets are clean and not blocked by anything.
2. **Attention:** Don't touch the device during the operation. This can cause injuries or damages.
3. **Unplug the YPOC 575 PRO from the AC outlet before any service.**
4. It is necessary to wait at least 30 minutes after disconnecting the AC before you open the **YPOC 575 PRO**. Please do not touch the bulb of the lamp if you are not absolutely sure it is cold. **-- Danger of BURNING --**
5. Never look directly into the beam of the lamp. You risk injury of your retina and blindness.
6. Pay attention of the maximum lamp operation time. You have to change it if the lamp shows any deformations or damages. The same is with all glass components, color filters, lenses and mirrors.
7. To allow a secure operation, follow also the Installation guide described in chapter 2. Operating the **YPOC 575 PRO** without suited safety aids like Safety cables or clamps/hooks can increase the risk of an accident.
8. The installation should be done by qualified staff only. You need to pay attention to the common rules of technology that are not explicit mentioned in this manual.
9. Use only original spare parts. Any structural modification will cancel all warranty adjustments.



**Attention:** Laser of class 3R may injure your retina after a short residence time even without any optical instrument. **Avoid any direct exposure of your eyes!**

## 2 Preparation and Installation

### 2.1 Mounting

The **YPOC 575 PRO** is fully operational whether it hangs or is mounted to the wall. It can also be operated while standing on the floor. Keep a safety distance of 0.5 m towards any easy inflammable materials (decoration etc.). Install a safety wire that can hold at least 10 times the weight of the fixture. Never use the carrying handles for secondary attachment.

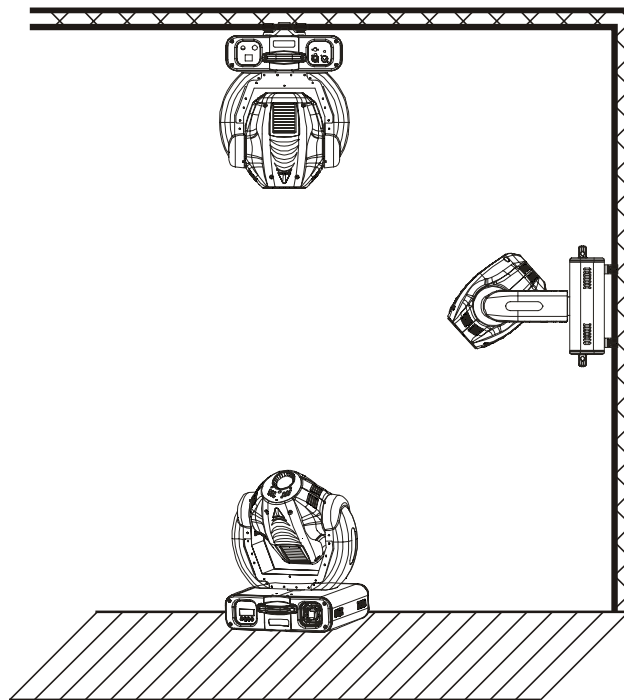

**Pay attention to the regulations of: BGV C1 (former VBG 70) and DIN VDE 0711-217. Regulations of show laser BGV B2 (11.2001), E DIN 56912 part 6, DIN-EN 60825 part 1+2. The installation should be done by qualified staff only.**

#### 2.1.1 Clamps

There are two major possibilities to mount the **YPOC 575 PRO** together with clamps. Camlock system or direct mounting of clamps. In both cases you have to regard a sufficient stability of the system. For installation instructions please see also printing on the backside of the case.

- a) Camlock system: This system allows you a fast and efficient setup of clamps. Attach the two camlocks to designated position on the backside

of the case and close the locks by turning them 90°. Verify the secure fit of the camlock system. The clamps themselves are directly attached permanently on the camlocks.

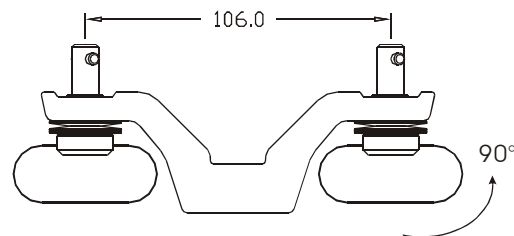

- b) Use two clamps direct on the backside of the **YPOC 575 PRO** to mount the unit on a truss (each two opposite threads max. M10x20).

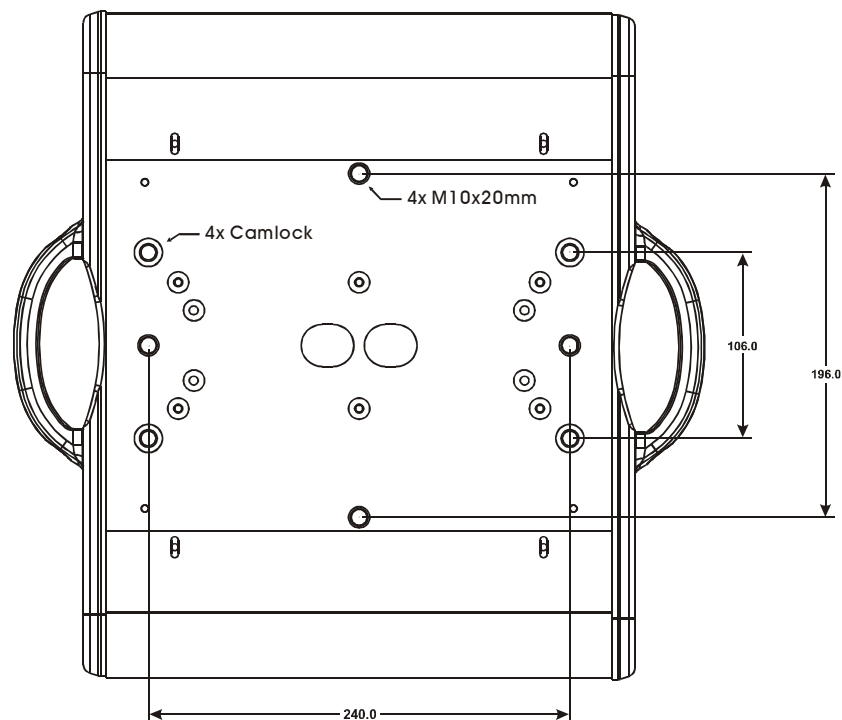

## 2.2 Secure the YPOC 575 PRO

Regardless of the rigging of the **YPOC 575 PRO** you have to use a stipulated safety wire. Therefore you have to thread to safety wire through to two provided holes on the backside of the fixture and connect it with the truss-support. Pay attention to a safe and proper fastening.



## 2.3 Connections

### 2.3.1 Power supply

Electronic ballast with:

~90 - 260 Volt, 50 - 60 Hz, earth contact type plug - Powercon

Connected load 780W  $\Leftrightarrow$  3.8 A (blind current compensation).

Please see printing on the case for the right electronic supply!

### 2.3.2 DMX

DMX 512 Standard input/output. See also printing on the case for the right pin assignment.

[+] = Pin 3 / [-] = Pin 2 / [Ground] = Pin 1

The DMX- Addressing starts at the DMX- Address [001].

## 2.4 Fuse

The **YPOC 575 PRO** electronic system is protected by two 5x20 mm fine-wire fuses.

Lamp: 230V / T 5A

Electronic: 230V / T 1A

Please see the printing on the **YPOC 575 PRO** casing for more details.

### Attention:

- **Disconnect AC outlet before changing a fuse!**
- **Use only the original declared fuse type!**

### 3 The Menu Field

You'll find the control board on the side part of the base. It allows you to make all necessary adjustments of the **YPOC 575 PRO**. With the **Mode**-key you get into the main menu. Afterwards you can navigate through the menu with the **Up/Down**-keys. Push the **Enter**-key to get in the next menu level or to confirm your settings. Make them and set functions **ON/OFF** with the **Up/Down**-keys. Confirm and save it with the **Enter**-key (the display shows OK). Push the **Mode**-key to cancel the entry and go back to the main menu.

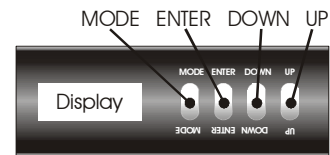

Level 1	Level 2	Level 3	Remark
DOO1			Define the DMX start address
TEST			Test program of all functions
AUDI	ASLW		Self-running audio program (slow)
	AFST		Self-running audio program (fast)
	MSTR		Master for the audio program
	SVPT		Basic position for the audio program
	SIZE		Size for the audio program (NORM-BIG-MIDL-SMAL)
LAMP			Switch on/of the lamp direct at the <b>YPOC 575 PRO</b>
RESE			Reset
TIME	POWR		Running time of the fixture (no destructible)
	LA1		Running time of the lamp (erasable)
	LA2		Running time of the lamp (no destructible)
RPAN			Reverse Pan-direction
RTL			Reverse Tilt-direction
SPEC	MANU		Manual drive of all device functions
	LAU		Automatic lamp start
	DLOF		Switch off lamp via DMX
	DMXI		Reed out actual DMX-values
	DISP	D ON	Display On/Off
		REV	Twist the display
	TEMP		Reed out internal temperature
	FANS	HIGH	Maximum cooling fan velocity
		REG	Automatic cooling fan control
		LOOF	Low cooling fan speed → lamp off
		LOHI	Low cooling fan speed → automatic
	ADJU	CODE xxxx	Use the code for entering the calibration menu (for authorized persons only)
		COLO	Calibration of the color wheel
		GOB1	Calibration of the gobo wheel 2
		GOB2	Calibration of the gobo wheel 2
		SHTR	Calibration of the shutter
		PRIS	Calibration of the prism wheel
		IRIS	Calibration of the iris
		POFS	Calibration of the Pan-Offsets
		TOFS	Calibration of the Tilt-Offsets
		CLRE	Settings in the internal memory (super-user only)
		ARES	Adjust Reset (wheels stand still after the reset)
		VTIL	Software version Tilt-board
		VTR1	Software version driver board 1
		VTR2	Software version driver board 2
		VTR3	Software version driver board 3
	DFSE		Call on the default function values
	FEED		Pan/Tilt feedback (error correction) On/Off
	EFLG		Correction of faults

← DOWN - UP →

### 3.1 *Adjust the DMX- Address (D001)*

Right after turning on the **YPOC 575 PRO** you can see the current DMX- Address. If there is no DMX- Signal the display flashes.

D001

For the address setting please follow this procedure:

1. Switch On the **YPOC 575 PRO** and wait until the fixture reset has finished ('RESE' is flashing in the display).
2. Press the **Mode**-key in order to access the main menu. Browse through the menu by pressing the **Up/Down**-keys until the display shows **D001**. Confirm by pressing the **Enter**-key (the decimal point is flashing)
3. Use the **Up/Down**-keys to select the desired address. Confirm the setting by pressing the **Enter**-key (the display shows **OK**) or press the **Mode**-key to cancel.

The DMX- Address is stored also while switching off the **YPOC 575 PRO!**

### 3.2 *The Test Program (TEST)*

test

The **Test**-Program allows you to run a complete self test procedure of all functions. Press **Enter** to confirm or **Mode** to cancel.

### 3.3 *The Audio Program (AUDI)*

Audi

The **Audio**-menu allows you to run a stand alone audio program. This chaser can run either fast or slow. **AFST**: Every sound impulse on step of the chaser. **ASlw**: Every second sound impulse one step of the chaser.

Additional you can choose a basic position for this audio chaser. Use therefore either the internal manual mode or an external controller to set the desired Pan/Tilt position. Confirm this setting in the **SVPT** menu by pressing the **Enter**-key.

You can also set the size of the audio chaser in the **SIZE** menu. You have the choice between: **NORM** (no basic position has to be chosen), **BIG**, **MIDL** and **SMAL**).

If you want to run the systems simultaneously, one of the **YPOCs** must be switched as the master. All others must be "Slave" Master = OFF. **Notice:** The Audio function is only working if **no** DMX is connected. This function can work e.g. on small events or as an emergency program.

### 3.4 Lamp On/Off (LAMP)

LAMP

Use the **Up/Down**-keys to select lamp **On** or lamp **Off** Press **Enter** to confirm or **Mode** to cancel and return to the main menu. (The lamp **OFF** command is only working if the shutter is closed at the same time. Use an external controller or the manual drive mode, see 3.9.1)

### 3.5 Reset (RESE)

RESE

Press the **Enter**-key to run a reset of all fixture functions (**RST** is shown in the display).

### 3.6 Running time of lamp and unit (TIME)

TIME

By this option can read out three different running times of the fixture.

POWR	Running time of the fixture (no destructible).
LA 1	Running time of the lamp (erasable). Push the <b>Up/Down</b> -keys at one time to delete this running time.
LA 2	Running time of the lamp (no destructible).

### 3.7 Invert Pan Movement (RPAN)

RPAN

This function allows you to invert the Pan movement. Use the **Up/Down**-keys to select invert **On** or **Off**. Press **Enter** to confirm or **Mode** to cancel and return to the main menu.

### 3.8 Invert Tilt Movement (RTLTL)

RTLTL

This function allows you to invert the Tilt movement. Use the **Up/Down**-keys to select invert **On** or **Off**. Press **Enter** to confirm or **Mode** to cancel.

### 3.9 Special Functions (SPEC)

SPEC

This menu allows you to enter further special functions of the **YPOC 575 PRO**.

In detail they are:

#### 3.9.1 Manual Drive (MANU)

MANU

This function allows you to drive all the fixture functions manually. Select the desired function with the **Up/Down**-keys and confirm with **Enter**. Now choose the desired value with the **Up/Down**-keys and confirm again with **Enter** or cancel and return to the menu with the **Mode**-key.

Function	Value	Remark
PAN	000 - 255	Pan Position
TILT	000 - 255	Tilt Position
COLO	000 - 255	Color wheel
GOB1	000 - 255	Gobo wheel 1
GROT	000 - 255	Gobo rotation
GOB2	000 - 255	Gobo wheel 2
SHUT	000 - 255	Shutter / Strobe function (the lamp strikes at DMX 255 if dimmer is "open" = DMX 255)
DIMR	000 - 255	Dimmer
FOCU	000 - 255	Focus
PRIS	000 - 255	Prism (000 – 127) / Stop / Prism- rotation
ORIS	000 - 255	Iris
SPEC	000 - 255	Lamp Off, Reset, Laser, ...

#### 3.9.2 Lamp On automatically (LAAU)

LAAU

This function enables to switch On the lamp automatically after switching

On the fixture. Use the **Up/Down**-keys to select **ON** if you want to switch on the lamp automatically after switching on the fixture or **Off** if you don't want this function. Press **Enter** to confirm or **Mode** to cancel and return to the menu.

If you have chosen **off** you have the possibility to start the lamp either via DMX or direct at the **YPOC 575 PRO** in the Lamp menu.

### 3.9.3 Lamp Off via DMX (DLOF)

#### DLOF

This function enables to switch off the lamp via DMX or not. Use the **Up/Down**-keys to select **ON** if you want to switch off the lamp via DMX or **Off** if you don't want this function. Press **Enter** to confirm or **Mode** to cancel and return to the menu.

If you have chosen **off** you have the possibility to switch off the lamp either direct at the **YPOC 575 PRO** in the Lamp menu or switch off the main switch.

### 3.9.4 DMX Input (DMXI)

#### DMXI

Readout DMX values of each channel received by the fixture. Use the **Up/Down**-keys to select desired channel and press **Enter** to read its value.

Function	Value	Remark
PAN	000 - 255	Pan Position
TILT	000 - 255	Tilt Position
COLO	000 - 255	Color wheel
GOB1	000 - 255	Gobo wheel 1
GROT	000 - 255	Gobo rotation
GOB2	000 - 255	Gobo wheel 2
SHUT	000 - 255	Shutter / Strobe function
DIMR	000 - 255	Dimmer
FOCU	000 - 255	Focus
PRIS	000 - 255	Prism wheel
IRIS	000 - 255	Iris
SPEC	000 - 255	Lamp Off, Reset, Laser, ...
MOVE	000 - 255	Movement
SPED	000 - 255	Speed Pan/Tilt

### 3.9.5 Display (DISP)

DISP

Use this function to choose between different display indications. Use the **Up/Down**-keys to select desired function and press **Enter** to confirm or **Mode** to cancel and return to the menu.

D ON	Display On/Off (If you've chosen <b>off</b> , the display will go out within 15 seconds after the last input. The next key touch will reactivate the display).
REV	Turn around the display. <b>Note:</b> You can also do this by pushing the <b>Up/Down</b> -keys at the same time.

### 3.9.6 Fixture Temperature (TEMP)

TEMP

This function allows you to read out the actual temperature of the **YPOC 575 PRO**. Press **Enter** to confirm or **Mode** to cancel. Inside temperatures below 80°C are not critical. 80°C and more lead the lamp being switched off at a critical point. Please note for a save operation that the outside temperature should not exceed 45°C.

### 3.9.7 Fan Control (FANS)

FANS

By using this function you can choose between 4 types of fan speed operations. Use the **Up/Down**-keys to select desired function and press **Enter** to confirm or **Mode** to cancel and return to the menu.

HIGH	The cooling fan works continuously at max. speed.
REG	The fan automatically raises its speed in order to control inside temperature of the fixture.
LOOF	The fan keeps the adjusted low speed until the temperature exceeds max. inside temperature, then the <b>YPOC 575 PRO</b> automatically <b>switch off</b> the lamp.
LOHI	The fan keeps the adjusted low speed until the temperature exceeds max. inside temperature, then the <b>YPOC 575 PRO</b> automatically switch from low to high fan speed.

In addition to these settings, you can set to fan speed to minimum via DMX (Special channel, DMX value 224..229). This will last until a temperature of 90° is reached.

### 3.9.8 Adjustments and Calibrations (ADJU)

#### ADJU

By this function you can adjust and calibrate the positions of the different wheels and other motors. This can be necessary after a service or repair work.

For this function you have to enter the fixture code. This work should be done only by authorized persons.

Use the **Up/Down**-keys to select desired function and press **Enter** to confirm or **Mode** to cancel and return to the menu. Use now the **Up/Down**-keys to set the adjustment values and confirm once more with the **Enter**-key or cancel with the **Mode**-key.

Function	Value	Remark
ADJU	CODE xxxx	Adjustments in the internal setup are code protected (for authorized persons only).
COLO	- 99 - + 99	Adjustment of the Color wheel
GOB1	- 99 - + 99	Adjustment of the Gobo wheel 1
GOB2	- 99 - + 99	Adjustment of the Gobo wheel 2
SHTR	- 99 - + 99	Adjustment of the Shutter
PRIS	- 99 - + 99	Adjustment of the Prism wheel
IRIS	- 99 - + 99	Adjustment of the Iris
POFS	- 99 - + 99	Adjustment of the Pan-Offsets
TOFS	- 99 - + 99	Adjustment of the Tilt-Offsets
CLRE	Adjustments in the internal circuit.	
ARES	- 99 - + 99	Adjust Reset (wheels stand still after the reset)
VTIL	- 99 - + 99	Software version of Tilt-board
VTR1	- 99 - + 99	Software version of Head- board
VTR2	- 99 - + 99	Software version of Base- board

### 3.9.9 Default Settings (DFSE)

#### DFSE

Press **Enter** to reset all fixture personalities (not the adjusted functions) to the default values. On the display will appear **OK** to indicate that the defaults are set.



Function	Display	Default Settings			
DMX Address	D001	D001			
Pan reverse	RPAN	ON		OFF	✓
Tilt reverse	RTLTL	ON		OFF	✓
Automatic lamp on	LAAU	ON		OFF	✓
Lamp on via DMX	DLOF	ON	✓	OFF	
Display	DISP	D	ON	✓	
Cooling fan	FANS	HIGH	REG	✓	LOOF   LOHI
Feedback	FEED	ON	✓	OFF	

### 3.9.10 Feedback (FEED)

FEED

The **YPOC 575 PRO** is provided with a automatic position correction (feedback) for the Pan and Tilt movement. Use the **Up/Down**-keys to select **ON** if you want to enable the feedback function or **Off** if you don't want this function. Press **Enter** to confirm or **Mode** to cancel and return to the menu.

### 3.9.11 Correction of faults (EFLG)

EFLG

(Function available for authorized persons only)

## 3.10 Error and Information Messages

<b>HEAT</b>	This message appears if you try to switch on the lamp within 5 minutes after having switched off (lamp too hot). The message will appear on the display if the lamp doesn't ignite within 20 seconds. The fixture will store this command and automatically ignite the lamp after 5 minutes.
<b>IG E</b>	When igniting the lamp, the electronic ballast will examine whether the lamp ignited or not. If the lamp does not ignite within 20 seconds, the igniting sequence is broken off. Now approx. 2 minutes are waited, until a renewed ignition attempt is started automatically. After the 3rd unsuccessful ignition attempt the sequence is completely stopped and the display reads "IG E" (Ignition error).
<b>LAER</b>	As soon as the lamp ignited correctly, the lamp current is constantly supervised by the system. If an interruption steps on (covers opened or lamp damaged), the power is switched off immediately. The display reads "LAER" (lamps error). Please switch off the power supply and solve the possible problem.

After the error "IG E" respectively "LAER" it is not anymore possible the start the lamp via Shutter = 255. Nevertheless if a renewed ignition attempt is desired, first run a Reset (at the Spot or over DMX). Afterwards you can try again to ignite the lamp.

<b>OTMP</b>	This error message informs you that the fixture was overheating and that the relay switches off the lamp. Please look for possible reasons (fan faulty, air in/outlets blocked or very dirty, lamp broken or very old, too high ambient temperature. Switch off the power supply and solve the possible problem.
<b>RSER</b>	This message informs you that one of the fixture function wasn't able to do its reset correct (magnetic sensor, stepping motor, driver on the PCB, cables, etc.). Repair the defect and start the fixture again.

#### 4 DMX Channel Selection (DMX Protocol)

Channel	Function	Time and Value	DMX	HEX	%
<b>1) PAN-coarse</b>	0 .. 530°	min. 2,65 s	0..255	00..FF	0..100
<b>2) PAN-fine</b>	High- Pos ... High- Pos + 2,1° (16 Bit)		0..255	00..FF	0..100
<b>3) Tilt-coarse</b>	0 .. 285°	min. 1,8 s	0..255	00..FF	0..100
<b>4) Tilt-fine</b>	High- Pos ... High- Pos + 1,1° (16 Bit)		0..255	00..FF	0..100
<b>5) Color</b>	open (fast)	Chaser from color to color max. 140 BPM => 0,43 s	0..1	00..01	0,2
	open / color 1 (fast)		2..3	02..03	1,0
	color 1, Brilliant Blue (fast)		4..5	04..05	1,8
	color 1 / color 2 (fast)		6..7	06..07	2,5
	color 2, Blue (fast)		8..9	08..09	3,3
	color 2 / color 3 (fast)		10..11	0A..0B	4,1
	color 3, Blue Purple (fast)		12..13	0C..0D	4,9
	color 3 / color 4 (fast)		14..15	0E..0F	5,7
	color 4, Magenta (fast)		16..17	10..11	6,5
	color 4 / color 5 (fast)		18..19	12..13	7,3
	color 5, Pink (fast)		20..21	14..15	8,0
	color 5 / color 6 (fast)		22..23	16..17	8,8
	color 6, Orange (fast)		24..25	18..19	9,6
	color 6 / color 7 (fast)		26..27	1A..1B	10,4
	color 7, Canary (fast)		28..29	1C..1D	11,2
	color 7 / color 8 (fast)		30..31	1E..1F	12,0
	color 8, Italian Blue (fast)		32..33	20..21	12,7
	color 8 / color 9 (fast)		34..35	22..23	13,5
	color 9, Turquoise (fast)		36..37	24..25	14,3
	color 9 / color 10 (fast)		38..39	26..27	15,1
color 10, Jade (fast)	40..41	28..29	15,9		
color 10 / color 11 (fast)	42..43	2A..2B	16,7		
color 11, Red (fast)	44..45	2C..2D	17,5		
color 11 / open (fast)	46..47	2E..2F	18,2		
open (fast)	48..63	30..3F	19,0		

Channel	Function	Time and Value	DMX	HEX	%
	open (slow)	Chaser from color to color max. 70 BPM => 0,86 s	64..65	40..41	25,3
	open / color 1 (slow)		66..67	42..43	26,1
	color 1, Brilliant Blue (slow)		68..69	44..45	26,9
	color 1 / color 2 (slow)		70..71	46..47	27,6
	color 2, Blue (slow)		72..73	48..49	28,4
	color 2 / color 3 (slow)		74..75	4A..4B	29,2
	color 3, Blue Purple (slow)		76..77	4C..4D	30,0
	color 3 / color 4 (slow)		78..79	4E..4F	30,8
	color 4, Magenta (slow)		80..81	50..51	31,6
	color 4 / color 5 (slow)		82..83	52..53	32,4
	color 5, Pink (slow)		84..85	54..55	33,1
	color 5 / color 6 (slow)		86..87	56..57	33,9
	color 6, Orange (slow)		88..89	58..59	34,7
	color 6 / color 7 (slow)		90..91	5A..5B	35,5
	color 7, Canary (slow)		92..93	5C..5D	36,3
	color 7 / color 8 (slow)		94..95	5E..5F	37,1
	color 8, Italian Blue (slow)		96..97	60..61	37,8
	color 8 / color 9 (slow)		98..99	62..63	38,6
	color 9, Turquoise (slow)		100..101	64..65	39,4
	color 9 / color 10 (slow)		102..103	66..67	40,2
	color 10, Jade (slow)		104..105	68..69	41,0
	color 10 / color 11 (slow)		106..107	6A..6B	41,8
	color 11, Red (slow)		108..109	6C..6D	42,5
	color 11 / open (slow)		110..111	6E..6F	43,3
	open (slow)		112..127	70..7F	44,1
	color rotation STOP		128..129	80..81	50
	color rotation, slow-fast, CW	min. 1,4 turns/h	130..191	82..BF	51..75
	color rotation, fast-slow, CCW	max. 2,9 turns/sec.	192..253	C0..FD	76..98
	Audio color chaser slow	each 4 <sup>th</sup> sound impulse → new color	254	FE	99
	Audio color chaser fast	each sound impulse → new color	255	FF	100
<b>6) Gobo 1</b>	Gobo 1 (open, fast)	Chaser from gobo to gobo max. 100 BPM => 0,6 s	0..7	0..7	0..2,9
	Gobo 2 (fast)		8..15	8..F	3..5,9
	Gobo 3 (fast)		16..23	10..17	6..8,9
	Gobo 4 (fast)		24..31	18..1F	9..11,9
	Gobo 5 (fast)		32..39	20..27	12..14,9
	Gobo 6 (fast)		40..47	28..2F	15..17,9
	Gobo 7 (fast)		48..55	30..37	18..20,9
	Gobo 8 (fast)		56..63	38..3F	21..23
	Gobo 1 (open, slow)	Chaser from gobo to gobo max. 40 BPM => 1,51 s	64..71	40..47	24..26,9
	Gobo 2 (slow)		72..79	48..4F	27..29,9
	Gobo 3 (slow)		80..87	50..57	30..33,9
	Gobo 4 (slow)		88..95	58..5F	34..36,9
	Gobo 5 (slow)		96..103	60..67	37..39,9
	Gobo 6 (slow)		104..111	68..6F	40..42,9
	Gobo 7 (slow)		112..119	70..77	43..45,9
	Gobo 8 (slow)		120..127	78..7F	46..49
	Gobo rotation STOP		128..129	80..81	50
	Gobo rotation, slow-fast, CW	min. 1,4 turns/h	130..191	82..BF	51..75
	Gobo rotation, fast-slow, CCW	max. 1.0 turns/sec.	192..253	C0..FD	76..98
	Audio gobo chase, slow	each 4 <sup>th</sup> sound impulse → new gobo	254	FE	99

Channel	Function	Time and Value	DMX	HEX	%
	Audio gobo chase, fast	each sound impulse → new gobo	255	FF	100
<b>7) Gobo 1 Posi./Rot</b>	Gobo position 0 ... 540°		0..127	00..7F	0..49
	Gobo rotation STOP		128..129	80..81	50
	Gobo rotation, slow-fast, CW	min. 2,0 turns/h	130..191	82..BF	51..75
	Gobo rotation, fast-slow, CCW	max. 3,8 turns/sec.	192..253	C0..FD	76..100
	Audio gobo rotation, slow	each 4 <sup>th</sup> sound impulse → new position	254	FE	99
<b>8) Gobo 2</b>	Gobo 1 (open, fast)	Chaser from gobo to gobo max. 100 BPM => 0,6 s	0..3	0..3	0..1
	Gobo 2 (fast)		4..7	4..7	2..2,9
	Gobo 3 (fast)		8..11	8..B	3..4
	Gobo 4 (fast)		12..15	C..F	5..5,9
	Gobo 5 (fast)		16..19	10..13	6..7
	Gobo 6 (fast)		20..23	14..17	8..8,9
	Gobo 7 (fast)		24..27	18..1B	9..10,9
	Gobo 8 (fast)		28..31	1C..1F	11..12
	Gobo 9 (fast)		32..35	20..23	13..13,9
	Gobo 10 (fast)		36..63	24..3F	14..24,9
	Gobo 1 (open, fast)	Chaser from gobo to gobo max. 40 BPM => 1,51 s	64..65	40..41	25..25,9
	Gobo 1 (open, slow)		66..67	42..43	26..26,9
	Gobo 2 (slow)		68..71	44..47	27..27,9
	Gobo 3 (slow)		72..75	48..4B	28..29
	Gobo 4 (slow)		76..79	4C..4F	30..30,9
	Gobo 5 (slow)		80..83	50..53	31..32
	Gobo 6 (slow)		84..87	54..57	33..34
	Gobo 7 (slow)		88..91	58..5B	35..35,9
	Gobo 8 (slow)		92..95	5C..5F	36..37
	Gobo 9 (slow)		96..99	60..63	38..38,9
	Gobo 10 (slow)	100..127	64..7F	39..50	
	Gobo rotation STOP		128..129	80..81	50
	Gobo rotation, slow-fast, CW	min. 1,4 turns/h	130..191	82..BF	51..75
	Gobo rotation, fast-slow, CCW	max. 1.0 turns/sec.	192..253	C0..FD	76..98
	Audio gobo chase, slow	each 4 <sup>th</sup> sound impulse → new gobo	254	FE	99
	Audio gobo chase, fast	each sound impulse → new gobo	255	FF	100
	Audio gobo rotation, fast	each sound impulse → new position	255	FF	100
	<b>9) Shutter</b>	Shutter closed		0..15	00..0F
Random Strobe (different pattern)			16..31	10..1F	7..11,9
Strobe Pulse effect , slow - fast		min. frequent 0,7 Hz	32..47	20..2F	12..12,9
Strobe effect , slow - fast		max. frequent 10 Hz	48..239	30..EF	13..93
Shutter open (lamp start)			240..255	F0..FF	94..100
<b>10) Dimmer</b>	Dimmer closed (0%)		0..3	0..3	0..1
	Dimmer 1%...99%	movement time 0,3 sec.	4..251	4..FB	2..98
	Dimmer open (100%)		252..255	FC..FF	99..100
<b>11) Focus</b>	In - out	full distance 1,5 sec.	0..255	0..FF	0..100
<b>12) Prism</b>	Prism swing out		0..5	00..05	0..2
	Prism position 0 ... 540°		6..127	06..7F	0..49
	Prism rotation stop		128..129	80..81	50
	Prism rotation, slow-fast, CW	min. 1,6 turns/h	130..191	80..BF	51..75
	Prism rotation, fast-slow, CCW	max. 4,4 turns/sec.	192..253	C0..FD	76..100

Channel	Function	Time and Value	DMX	HEX	%	
	Audio prism rotation, slow	each 4 <sup>th</sup> sound impulse → new prism	254	FE	99	
	Audio prism rotation, fast	each sound impulse → new prism	255	FF	100	
<b>13) Iris</b>	Iris open – closed		0..127	00..7F	0..50	
	Ascend with Shutter, random		128..143	80..8F	51..56	
	Descend with Shutter, random		144..159	90..9F	57..62	
	Ascend with Shutter, audio		160..175	A0..AF	63..68	
	Descend with Shutter, audio		176..191	B0..BF	69..75	
	Ascend with Shutter		192..207	C0..CF	76..81	
	Descend with Shutter		208..223	D0..DF	82..87	
	Pulse - effect		224..239	E0..EF	88..93	
	Ascend - descend effect		240..253	F0..FD	94..99	
	Iris open		254..255	FE..FF	100	
<b>14) Special</b>	No function		0..15	00..0F	0..6	
	Gobo-shake +/- 10° slow – fast	3,5 moves / min. up to 60 moves / max.	16..31	10..1F	7..12	
	Gobo-shake +/- 20° slow – fast	3,5 moves / min. up to 60 moves / max.	32..47	20..2F	13..18	
	Gobo-shake +/- 30° slow – fast	3,5 moves / min. up to 60 moves / max.	48..63	30..3F	19..24	
	Color-chaser C / C+1 slow – fast	0,7 BPS ... 2,3 BPS => 1,43 s ... 0,43 s	64..79	40..4F	25..31	
	Color-chaser C / C+2 slow – fast	0,7 BPS ... 2,0 BPS => 1,43 s ... 0,5 s	80..95	50..5F	32..37	
	Audio Pan / Tilt slow	each 4 <sup>th</sup> sound impulse → new position	96..111	60..6F	38..43	
	Audio Pan / Tilt fast	each sound impulse → new position	112..127	70..7F	44..50	
	Laser flashing, random		128..143	80..8F	51..56	
	Laser, audio		144..159	90..9F	57..62	
	Laser blinking, slow - fast		160..175	A0..AF	63..68	
	Laser flashing, slow - fast		176..191	B0..BF	69..74	
	Laser ON		192..207	C0..CF	75..81	
	No function		208..223	D0..DF	82..87	
	Fan on min. as long as temp. < 90°C		224..229	E0..E5	88..90	
	Lamp OFF (min. 3 sec.)		230..249	E6..F9	92..97	
	Reset		250..255	FA..FF	98..100	
	<b>15) Move- ment</b>	no movement		0	00	0
		<b>Movement</b>	<b>Size</b>	<b>Phase</b>		
PAN		1	0°	01..01	01..01	0,5
		1	90°	02..03	02..03	1,0
		1	180°	04..05	04..05	1,7
		1	270°	06..07	06..07	2,5
PAN		2	0°	08..09	08..09	3,3
		2	90°	10..11	0A..0B	4,1
		2	180°	12..13	0C..0D	4,9
		2	270°	14..15	0E..0F	5,7
PAN		3	0°	16..17	11..11	6,5
		3	90°	18..19	12..13	7,3
		3	180°	20..21	14..15	8,0
PAN		3	270°	22..23	16..17	8,8
		4	0°	24..25	18..19	9,6

Channel	Function	Time and Value	DMX	HEX	%	
	4	90°	26..27	1A..1B	10,4	
	4	180°	28..29	1C..1D	11,2	
	4	270°	30..31	1E..1F	12	
	TILT		size / phase see also PAN	32..63	20..3F	13..25
	PAN / TILT		size / phase see also PAN	64..95	40..5F	26..37
	PAN / TILT (inverse)		size / phase see also PAN	96..127	60..7F	38..50
	Circle		size / phase see also PAN	128..159	80..9F	51..62
	Circle (inverse)		size / phase see also PAN	160..191	A0..BF	63..75
	lying eight		size / phase see also PAN	192..223	C0..DF	76..87
	random movement		size see also PAN	224..255	E0..FF	88..100
<b>16) Speed Pan/Tilt</b>	Pan/Tilt relative movement		0..15	00..0F	0..6	
	Pan/Tilt slow – fast Use this channel 14) also for the speed of the movements (channel 13).		Pan min. 530° = 200 s Pan max. 530° = 2,65 s Tilt min. 285° = 110 s Tilt max. 285° = 1,8 s	16..255	10..FF	7..100
<b>Lamp ON</b>	Shutter open		240..255	F0..FF	94..100	
<b>Lamp OFF</b>	Channel 14 ( min. 3 sec. ) (only if shutter is closed, channel 9 = 0 ..15)		230..249	6E..9F	92..97	

## 5 Change the Lamp

For a frictionless operation please read this chapter carefully and follow all instructions.

### 5.1 Safety Regulations

- **Pull out the main plug!**
- Wait min. 20 minutes after the last operation to cool down the fixture.
- Don't touch the bulb of the lamp with bare fingers (this can cause damages).
- Before you put the **YPOC 575 PRO** into operation close the casing, otherwise your retina can be hurt!

### 5.2 Realize the Lamp Change

#### 1. Pull out the main plug!

2. The lamp can be changed in a very comfortable way directly from the backside of the case without opening the head.
3. Open the four screws (1, 2, 3 and 4) of the backside lamp sheet and remove it carefully.
4. Remove the old or broken lamp by opening the two sidewise lamp screws.

**Attention:** The glass bulb of the lamp can splinter. For that reason remove the

lamp with safety gloves or some cloth.

5. Put in the new lamp securely with a tight fit into the socket and close the two lamp screws. The lamp filler neck must not in the direction lamp or lenses.  
**Attention:** Use only the original lamp type!
6. Pull the lamp holder safely back in the shaft and close the four screws.
7. The running time of the lamp LA1 can be reseed in the Time Menu.

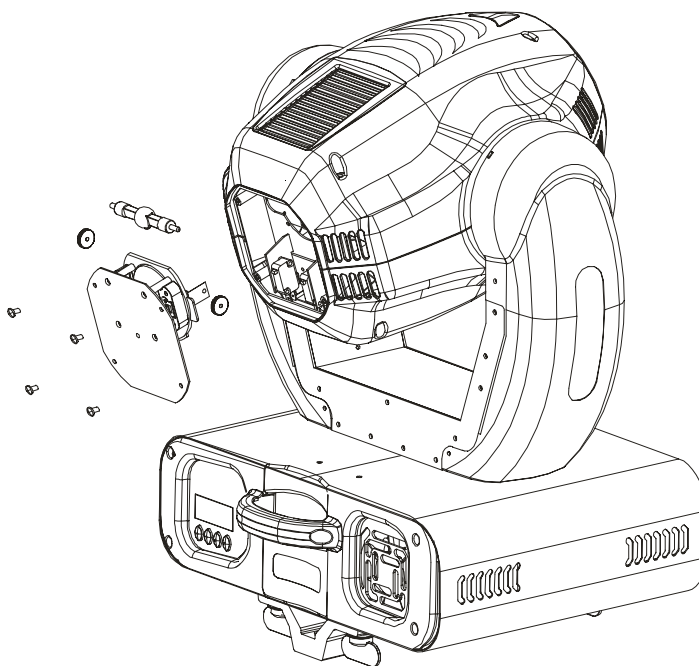

## 6 Change a Gobo

The **YPOC 575 PRO** is fitted with standard gobos (outside diameter 27 mm, image size 23 mm). You can use ether steel or glass gobos.

### 6.1 Safety Regulations

- **Pull out the main plug!**
- Wait min. 20 minutes after the last operation to cool down the fixture.
- Before you put the **YPOC 575 PRO** into operation close the casing, otherwise your retina can be hurt!

### 6.2 Realize the Gobo Change

1. **Pull out the main plug!**
2. Open the upper shell of the head casing by loosening the 4 Phillips screws. Two on the front side and 2 on the back side of the head.
3. Rotating Gobo-wheel: Remove the gobo out of the centric spring. Afterwards the gobo can be changed outside.



4. The Gobo-clamp with the magnet must be **always** opposite to the "open" position. If an exchange is necessary please replace the Gobo itself inside the mounting plate. **Use never two mounting plates with magnets at the same time!**
5. Fixed Gobo-wheel: Please remove the gobo directly out of the Gobo-spring.
6. Change the desired gobo and fix it again under the spring.
7. Close the **YPOC 575 PRO** in reverse order.

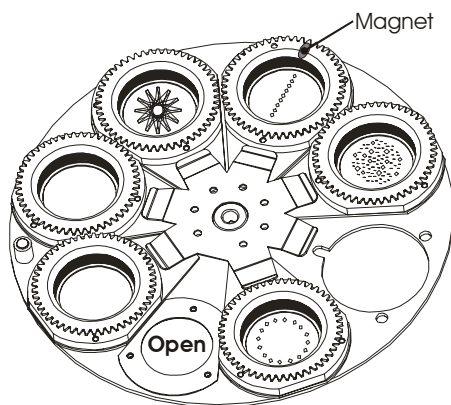

Wheel with rotating Gobos

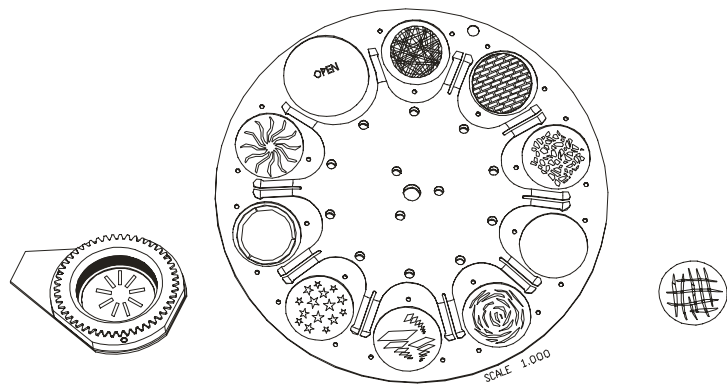

Wheel with non rotating Gobos

**Attention:**

If you use glass gobos, the non-vaporized side must be fitted towards the lamp direction.

## 7 Maintenance and Cleaning the YPOC 575 PRO

It is absolutely essential that the fixture is kept clean and that dust, dirt and smoke-fluid residues must not built up on or within the fixture. Otherwise the fixture's light-output will be significantly reduced. Regular cleaning will not only ensure the maximum light-output, but will also allow the fixture to function reliable throughout its life.

**A soft lint-free cloth moistened with any good glass cleaning fluid is recommended, under no circumstances should alcohol or solvents be used!**

The inside optical system should be maintained only by authorized persons. Please contact your local dealer.



## 7.1 Safety Regulations

- **Pull out the main plug!**
- Wait min. 20 minutes after the last operation to cool down the fixture.
- Before you put the **YPOC 575 PRO** into operation close the casing, otherwise your retina can be hurt!

## 7.2 Circumference and Interval (rule-of-thumb)

The contamination of the fixture depends on the environment details. Therefore no general guidelines can be given. From this it follows that the intervals are only suggestions from our practice experience.

Position	Interval	In this way
Outside optic	weekly	soft cloth and glass cleaning fluid
Color filter	monthly	soft cloth and glass cleaning fluid
Gobos	yearly	vacuum cleaner, airbrush, etc.
Glass gobos	monthly	soft cloth and glass cleaning fluid
Prism	monthly	soft cloth and glass cleaning fluid
Dimmer/Shutter/Iris	yearly	vacuum cleaner, airbrush, etc.
Inside lens	monthly	soft cloth <b>no</b> glass cleaning fluid
Fan and air channel	monthly	vacuum cleaner, airbrush, etc.
Reflector	<b>never</b>	
Lamp	<b>never</b>	
Moveable parts	yearly	suitable fatty oil

### **Attention:**

1. **Never** let optical parts come into contact with oil or fat.
2. Before running the fixture wait until all parts are dried up.
3. **Never** clean the aspheric lens with water or other cleaners. Change the lens if it looks milky (about 1 - 2 years). For that please contact your local dealer.

## 7.3 Cleaning the Optical System

1. **Pull out the main plug!**
2. Wait min. 20 minutes after the last operation to cool down the fixture.
3. Open the upper shell of the head casing by loosening the 4 Phillips screws.  
Two on the front side and two on the back side of the head.
4. Do the work as explained in the list above.
5. Before you put the **YPOC 575 PRO** into operation close the casing, otherwise your retina can be hurt!

## 8 Technical Specification

<b>Power supply</b>	
<b>Power consumption</b>	~90 - 260V, 50 - 60 Hz 780 Watt, 3.8A, electronic ballast, (blind current compensated)
<b>Fuse protection</b>	Lamp: T 5A, 250V, 5x20 mm (fine-wire fuse) Electronic: T 1A, 250V, 5x20 mm (fine-wire fuse)
<b>Lamp</b>	
<b>Type</b>	HTI 575-DE (OSRAM)
<b>Live time</b>	500h (750h)
<b>Color temperature</b>	5600k or 7500k
<b>luminous flux</b>	43.000 lm
<b>Optical system</b>	
Parabolic reflector	
Doubles condenser lens	
15° standard objective (optional 15° or 18°)	
Lens anti-reflex	
<b>Color</b>	
11 dichroic filter plus white, 12 half-colors	
<b>Gobos</b>	
Gobo-wheel 1: 7 exchangeable rotating gobos plus "open", 4 glass Gobos	
Gobo-wheel 2: 9 fixed exchangeable standard gobos plus "open"	
Gobo outside diameter 27 mm, image size 23 mm	
All gobos as steel or glass Gobos exchangeable, 9 spare Gobos	
Gobo thickness: glass = 1.1 mm, steel = 0.15 mm	
<b>Shutter / Strobe / Dimmer</b>	
Strobe- effect with variable speed 1 - 10 flashes per second	
Continuously mechanical dimmer 0 - 100%	
<b>Prism</b>	
Rotating 3-face prism, rotating and variable in speed	
<b>Focus</b>	
Motor driven focus from near to far away	
<b>Drive</b>	
Standard DMX-512, 3 pole XLR; [+] = Pin 3 [-] = Pin 2 [Ground] = Pin 1. The DMX- addressing starts at the DMX- address [001].	
<b>Pan / Tilt</b>	
<b>Pan- movement</b>	<b>530° in max. 2,65 seconds, 16 bit resolution</b>
<b>Tilt- movement</b>	<b>280° in max. 1,68 seconds, 16 bit resolution</b>
<b>Weights and measures</b>	
<b>Width of the base</b>	<b>375 mm</b>
<b>Length of the base</b>	<b>430 mm</b>
<b>height (head vertical)</b>	<b>450 mm</b>
<b>Weight (net)</b>	<b>19 kg</b>

## 9 Index

<b>A</b>	
<b>Adjustments</b> .....	16
aspheric lens .....	25
Audio .....	11
<b>B</b>	
BGV C1 .....	7
<b>C</b>	
<b>Calibrations</b> .....	16
Change a Gobo .....	23
Circumference .....	25
Clamps .....	7
Cleaning .....	25
<b>D</b>	
Description of Device .....	5
DIN VDE 0711-217 .....	7
Display .....	15
<b>DMX</b> .....	9
<b>DMX- Address</b> .....	11
DMX Input .....	14
DMX Protocol .....	18
<b>E</b>	
<b>Error Messages</b> .....	17
<b>F</b>	
Fan .....	15
Feedback .....	17
Fixture Temperature .....	15
Fuse .....	9
<b>G</b>	
Glass Gobos .....	24
<b>I</b>	
Injury of the retina .....	6
Invert .....	12
<b>M</b>	
<b>Maintenance</b> .....	24
Measures .....	26
Menu Field .....	10
Mounting .....	7
<b>P</b>	
Pan- movement .....	26
Power supply .....	9
<b>R</b>	
<i>Reset</i> .....	12
Running time .....	12
<b>S</b>	
Safety Instructions .....	6
Secure the YPOC 250 .....	8
Special Functions .....	13
<b>T</b>	
Technical Specification .....	26
Test Program .....	11
Tilt- movement .....	26
<b>V</b>	
VBG 70 .....	7
<b>W</b>	
Weights .....	26

