

#### Remarks:

- DIP SWITCH NO.1 & NO.10 in "ON" control via dmx controller
- DIP SWITCH NO.1 & NO.10 in "ON". The mini-controller can be use to control the laser light.
- When using DMX, the mini-controller function is not available. When using mini-controlle control, the DMX is not available.
- When not using any controller to control laser , set DIP SWITCH No.1 "ON", then the laser light will be in automatic mode
- Link laser to master & slave by DMX control, Master & slave DIP SWITCH setting to No.1 & NO.10 in "ON", then all lasers will show same patterns & work together in sync.
- Link laser to master & slave by DMX control, Master laser DIP SWITCH setting to No.1 & NO.10 in "ON", slave lasers DIP SWITCH setting will follow laser function
- Use DMX channel binary numbers to set different head addresses in each unit. Then all lasers will show different patterns via DMX controller programming
- When no using any controller to control laser, the laser will be in automatic and sound active mode. The laser can be linked in master and slave mode. From master 5-XLR to slave 3-XLR.

#### **THE DIP SWITCH SETTINGS**

**Master DIP SWITCH address: NO.1  
and NO.10 in "OFF".**

**All slaves DIP SWITCH address: NO.2 in "ON".**

- The DMX LASER 120 PRO is designed with a blackout function.

- A:** When no sound is present the laser will go into blackout mode
- B:** When the sensitivity is set to low the laser will go into blackout mode
- C:** When no DMX signal, the laser will go into blackout mode
- D:** When OFF DMX signal, the laser will go into blackout mode
- E:** Under DMX signal control to Manual with sound active mode, blackout function is not available.

#### **Technical Specification**

**Operation Voltage:** AC 220/240V/50Hz

**Working power:** 30W

**Laser Wavelength:** 532nm

**Laser power:** 80mW

**Laser class:** Class IIIb

**Fuse:** 3A F

**Insulation Resistance:** >2M

**Channels:** 12 channels

**Control signal:** DMX512 signal

**Control mode:** Mini-Controller/Sound active/Automatic DMX Linkable

**Net weight:** 4.20Kg

**Dimensions:** 225x300x280mm

**Attention: The laser light is designed indoor use only Working temperature in 10° ~ 60°C.**

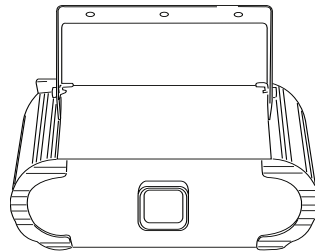

**KAM**  
LIGHTING

**DMX LASER 40**

**Due to continuous product development, specifications and appearance are subject to change. E&O E.**

**KAM**  
LIGHTING

**DMX LASER 120**

instruction manual

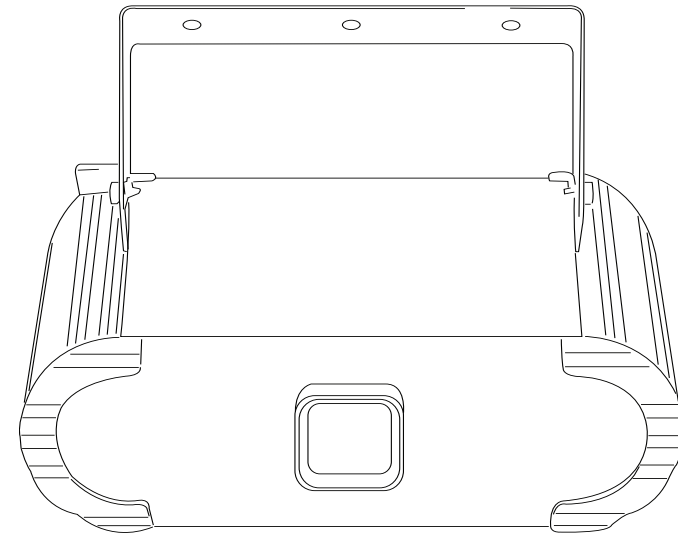

**www.kam.co.uk**

## INTRODUCTION

Thank you for purchasing the **DMX LASER 120 PRO** To optimize the performance of this product, prior to use, please read these operating instructions carefully to familiarize yourself with the basic operations of this unit. **DMX LASER 120 PRO** light has the **KAM funky design** and is an amazing **Laser effect**. Please keep these user instructions in safe place for future reference. This unit has been Tested at the factory before being shipped to you. There is no Assembly required.

## WARNING!

To prevent or reduce the risk of electrical shock or fire, do not expose this unit to high Temperature / rain or moisture.

Laser Class 3B product. National Regulations must be adhered to at all steps of installation.

(In Germany apply DIN 56912 and BGVR LASER note: additional Regulations may apply).

Unintended reflections of the laser beam from reflective or metallic surfaces can be dangerous.

This appliance is to used by Qualified personnel only.

## Laser Radiation Warning

This unit uses diode lasers in green colour. This is CLASS 3B laser product.

Avoid exposure to eyes. Never open the laser diode box , please refer unit to a qualified engineer for servicing or repairs

## DMX LASER 120 PRO FEATURES

Sound activation  
High laser output  
DMX 512 signal control  
Optional mini-controller  
High-speed optical scanner.  
X+Y scanning module unit can display many different laser patterns, °move°rotation °split °slow-draw°blackout, enlarge and shrink image and so on  
The unit can be used for mobile DJ'S, roller rinks, disco, clubs and many applications

## Packing

Every DMX LASER 120 PRO has been thoroughly tested, and in perfect working order before being shipped to you.

When you receive the unit, please open the packing to check. carefully the carton for damaged that may have occurred during shipping. If the carton appears to be damaged, carefully inspect your laser for any damage.

In the case damage has been found please contact to the dealer you purchased it from

## Installation

Be sure that the mains power outlet matches the required voltage for the laser 220v-240v

- The LASER LIGHT must be installed by a qualified technician.
- Always be sure to mount this unit in area that will allow proper ventilation. Allow about 6”(15cm) between this laser and a wall.
- For safety, the laser must be earthed

## Instructions

Please follow these instructions, to ensure a long and safe life for your LASER

- Keep the laser clean.
- Do not attempt to operate this unit, if it becomes damaged in any way.
- Never operate this unit when it's cover is removed.
- Disconnect from mains power before carrying out any maintenance
- To prevent or reduce the risk of electrical shock or fire, do not expose this unit to rain or moisture.
- Never block the ventilation holes.
- Do not attempt to operate this unit if the power cable has been damaged

## REAR PANEL

**POWER SWITCH:** ON/OFF

**DMX INPUT:** DMX signal input---Male XLR

**DMX OUTPUT:** DMX signal output---Female XLR

**MINI-CONTROLLER:** Use 5 pix XLR Male connection.

**DIP SWITCH:** DMX address

**MIC:** Sound active

**Min-Max:** Adjust the sensitivity knob for sound activation

**ZOOM:** Adjust the patterns size large and small

**KEY:** LOCK laser

## DMX channels functions and options

When using a DMX controller,

DIP SWITCH 1~10 setting as follows:

NO.1 & NO.10 in "ON" unit controlled by DMX.

- Using a DMX controller set No.1ch to on Manual mode or Automation mode and then set No.2ch to on line.
- Using a DMX controller, please note No.4ch to Off, speed function doesn't work. set No.4ch speed CLASS function begin from 1 to large.

CHANNEL	DMX512 OPTIONS	FUNCTION
1	0~63	Sound activation mode
	64~127	Automatic mode
	128~191	Manual mode with sound activation
	192~255	Automatic mode with sound activation
	0~63	Blackout
2	64~127	Line
	128~191	Line-split pulse
	192~255	On blanking off
3	0~255	Select patterns (128 patterns)
	0~127	manual control of gobo vertical
4	128~191	Gobo auto down moving with speed control
	192~255	Gobo auto up moving with speed control
	0~127	manual control of gobo Horizontal
5	128~255	Gobo auto right moving with speed control
	192~255	Gobo auto left moving with speed control
6	0~127	manual control of gobo vertical turn
	128~255	Gobo auto vertical turn, with speed control
	0~127	manual control of gobo horizontal turn
7	128~255	Gobo auto horizontal turn, with speed control
	0~127	manual control of gobo rotation
8	128~191	Gobo auto anticlockwise rotation with speed control
	192~255	Gobo auto clockwise rotation with speed control
	0~85	Zoom gobo from small to large with speed control
9	86~170	Zoom gobo from large to small with speed control
	171~255	Zoom gobo exchange large and small with speed control
10	0~255	Gobo size from small to big, "0" is fix size, "1" is small size , "255" is big size
11	0~255	Begin "1" dotting from dark to bright. "0" is no dotting,
12	0~127	Slow-draw first way with speed control
	128~255	Slow-draw second way with speed control

