

36x10W Smart LED Zoom Moving Head Light

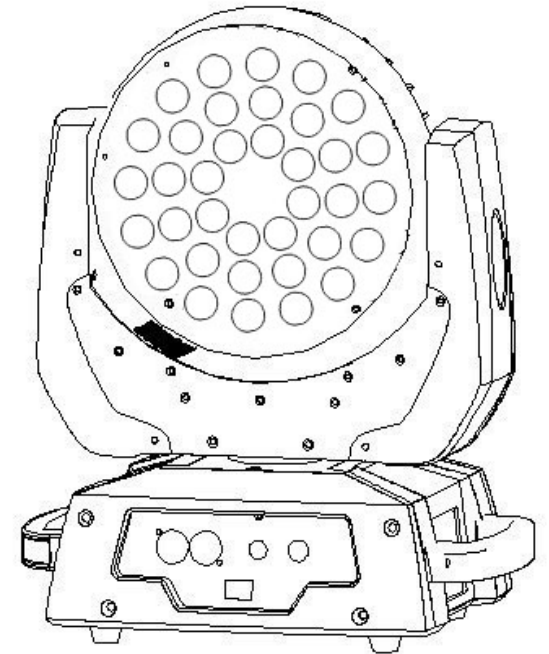

1. Unpacking

. For your own safety, please read this manual before installing the device. This manual covers the important information on installation and applications. Please install and operate the fixture with following instructions. Meanwhile, please keep this manual well for future needs.

high temperature strength of engineering plastics and cast aluminum casing with nice outlook. The fixture is designed and manufactured strictly following CE standards, complying with international standard DMX512 protocol. It's available independently controlled and linkable with each other for operation. And it is applicable for large-scale live performances, theater, studio, nightclubs and discos.

adopts 36PCS CREE 10W 4-in-1 LED lamps which features high brightness and stability. Please carefully unpack it when you receive the fixture and check whether it is damaged during the transportation. And please check whether the following items are included inside the box:

Moving Head----- one	Signal Cable----one
Omega Clamp-----one	User Manual----one
Power Cable-----one	Safety Chain----one

10. Maintenance and Cleaning

The following points have to be considered during the inspection:

- 1) All screws for installing the devices or parts of the device have to be tightly connected and must not be corroded.
- 2) There must not be any deformations on the housing, color lenses, fixations and installation spots (ceiling, suspension, trussing).
- 3) Mechanically moved parts must not show any traces of wearing and must not rotate with unbalances.
- 4) The electric power supply cables must not show any damage, material fatigue or sediments.

Further instructions depending on the installation spot and usage have to be adhered by a skilled installer and any safety problems have to be removed.



CAUTION!

Disconnect from mains before starting maintenance operation.

In order to make the lights in good condition and extend the life time, we suggest a regular cleaning to the lights.

- 1) Clean the inside and outside lens each week to avoid the weakness of the lights due to accumulation of dust.
- 2) Clean the fan each week.
- 3) A detailed electric check by approved electrical engineer each three month, make sure that the circuit contacts are in good condition, prevent the poor contact of circuit from overheating.

We recommend a frequent cleaning of the device. Please use a moist, lint- free cloth. Never use alcohol or solvents.

There are no serviceable parts inside the device. Please refer to the instructions under "Installation instructions".

Should you need any spare parts, please order genuine parts from your local dealer.

9. Technical Specifications

Input Voltage: AC90-260V 50-60Hz

LED Quantities: 36PCS 10W CREE Quad LEDs

Control Signal: DMX512, master-slave and sound activated or auto operation

Control Channel: 15/39 DMX Channels switchable

Power Consumption: 420W

Dimensions: 350x260x350mm

Packing Dimensions: 430x300x400mm

Net Weight: 10.5kg

Gross Weight: 11.5kg

2. Safety Instructions



CAUTION!
Be careful with your operations. With a dangerous voltage you can
Suffer a dangerous electric shock when touching wires!

This device has left the factory in perfect condition. In order to maintain this condition and to ensure a safe operation, it is absolutely necessary for the user to follow the safety instructions and warning notes written in this user manual.



Important:

Damages caused by the disregard of this user manual are not subject to warranty. The dealer will not accept liability for any resulting defects or problems.

If the device has been exposed to temperature changes due to environmental changes, do not switch it on immediately. The arising condensation could damage the device. Leave the device switched off until it has reached room temperature. This device falls under protection-class I. Therefore it is essential that the device be earthed.

The electric connection must carry out by qualified person.

The device shall only be used with rate voltage and frequency.

Make sure that the available voltage is not higher than stated at the end of this manual.

Make sure the power cord is never crimped or damaged by sharp edges. If this would be the case, replacement of the cable must be done by an authorized dealer.

Always disconnect from the mains, when the device is not in use or before cleaning it.

Only handle the power cord by the plug. Never pull out the plug by tugging the power cord.

During initial start-up some smoke or smell may arise. This is a normal process and does not necessarily mean that the device is defective, it should decrease gradually. Please don't project the beam onto combustible substances.

Fixtures cannot be installed on combustible substances, keep more than 50cm distance with wall for smooth air flow, so there should be no shelter for fans and ventilation for heat radiation.

If the external flexible cable or cord of this luminaire is damaged, it shall be exclusively replaced by the manufacturer or his service agent or a similar qualified person in order to avoid a hazard.

3. Operation Instructions

- The moving head is an LED wash light for onsite decoration purpose.
- Don't turn on the fixture if it's been through severe temperature difference like after transportation because it might damage the light due to the environment changes. So make sure to operate the fixture until it is in normal temperature.
- This light should be keep away from strong shaking during any transportation or movement.
- Don't pull up the light by only the head, or it might cause damages to the mechanical parts.
- Don't expose the fixture in overheat, moisture or environment with too much dust when installing it. And don't lay any power cables on the floor. Or it might cause electronic shock to the people.
- Make sure the installation place is in good safety condition before installing the fixture.
- Make sure to put the safety chain and check whether the screws are screwed properly when installing the fixture.
- Make sure the lens are in good condition. It's recommended to replace the units if there are any damages or severe scratch.
- Make sure the fixture is operated by qualified personnel who knows the fixture before using.
- Keep the original packages if any second shipment is needed.
- Don't try to change the fixtures without any instruction by the manufacturer or the appointed repairing agencies.
- It is not in warranty range if there are any malfunctions from not following the user manual to operate or any illegal operation, like shock short circuit, electronic shock, lamp broke, etc.

29	Green	0-255	Green in D section
30	Blue	0-255	Blue in D section
31	White	0-255	White in D section
32	Red	0-255	Red in E section
33	Green	0-255	Green in E section
34	Blue	0-255	Blue in E section
35	White	0-255	White in E section
36	Red	0-255	Red in F section
37	Green	0-255	Green in F section
38	Blue	0-255	Blue in F section
39	White	0-255	White in F section

When it is 15CH mode, the channels are as the front 15 DMX channels in the above list.

8. Features

- 36PCS 10W high power CREE Quad Color LEDs
- Specific optic system
- 50,000 hours lifespan and low power consumption
- Smooth and precise resolution for PAN/TILT movement
- 540°/630° pan and 265° tilt movement
- Scan position memory, auto reposition after unexpected movement
- RGBW color mixing system
- LED shutter
- LED dimming
- LED rainbow effect
- Macros effect
- Strobe effect with 18 flashes per second and pulse effect
- General dimming and blackout for all four colors
- 15/39 DMX channels switchable from the menu
- DMX512, master-slave and sound activated controllable or auto operation
- Blue background LCD display

7. DMX Channels (15CH/39CH)

Channel	Function	Values	Description
1	PAN	0-255	Pan Movement, 540°
2	PAN Fine	0-255	Fine control of PAN movement
3	TILT	0-255	Tilt Movement, 270 °
4	TILT Fine	0-255	Fine control of TILT movement
5	Dimmer	0-255	0-100% Linear dimmer
6	Strobe	0-255	Strobe effect from slow to fast
7	Red	0-255	0-100% Red dimmer from dark to bright
8	Green	0-255	0-100% Green dimmer from dark to bright
9	Blue	0-255	0-100% Blue dimmer from dark to bright
10	White	0-255	0-100% White dimmer from dark to bright
11	Speed	0-255	Speed of PAN/TILT movement
12	Macro	0-255	Macro effect
13	Color Fading	0-255	Color fading effect
14	Auto	0-255	Auto running with built-in programs
15	Reset	0-255	Reset
16	Red	0-255	Red in A section
17	Green	0-255	Green in A section
18	Blue	0-255	Blue in A section
19	White	0-255	White in A section
20	Red	0-255	Red in B section
21	Green	0-255	Green in B section
22	Blue	0-255 </td <td>Blue in B section</td>	Blue in B section
23	White	0-255	White in B section
24	Red	0-255	Red in C section
25	Green	0-255	Green in C section
26	Blue	0-255	Blue in C section
27	White	0-255	White in C section
28	Red	0-255	Red in D section

4. Installation via clamp

Please refer to the picture below.

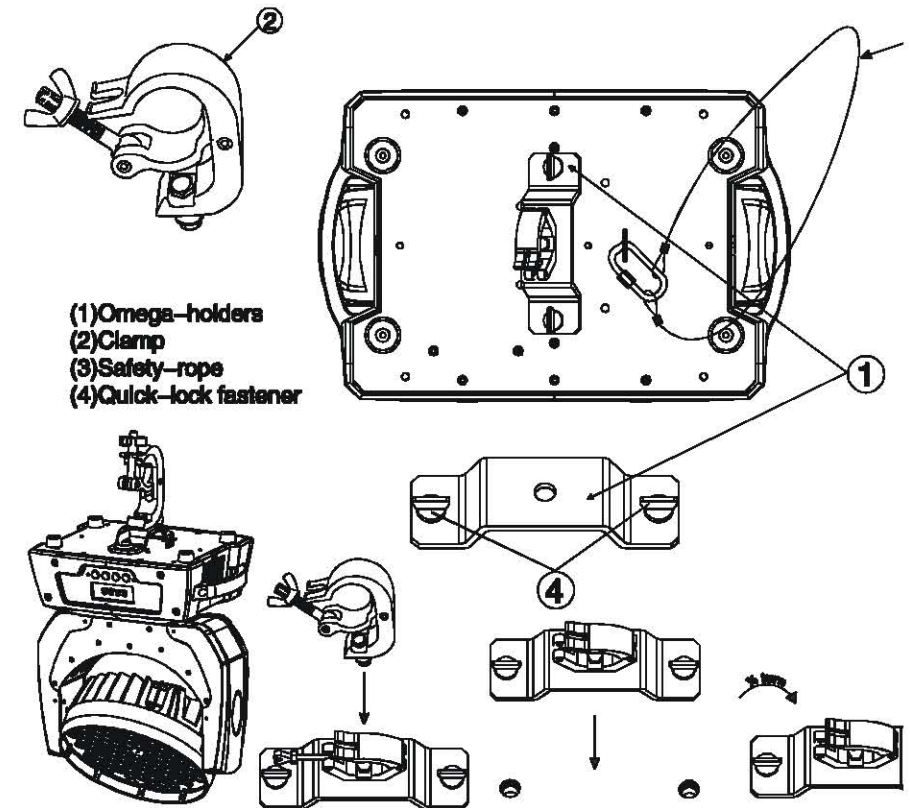

Screw one clamp each via a M12 screw and nut onto the Omega holders.

Insert the quick-lock fasteners of the first Omega holder into the respective holes on the bottom of the device. Tighten the quick-lock fasteners fully clockwise.

Install the second Omega holder.

Pull the safety-rope through the holes on the bottom of the base and over the trussing system or a safe fixation spot. Insert the end in the carabine and tighten the safety screw.

5. DMX-512 control connections

Connect the provided XLR cable to the female 3-pin XLR output of your controller and the other side to the male 3-pin XLR input of the moving head. You can chain multiple Moving head together through serial linking. The cable needed should be two core, screened cable with XLR input and output connectors. Please refer to the diagram below.

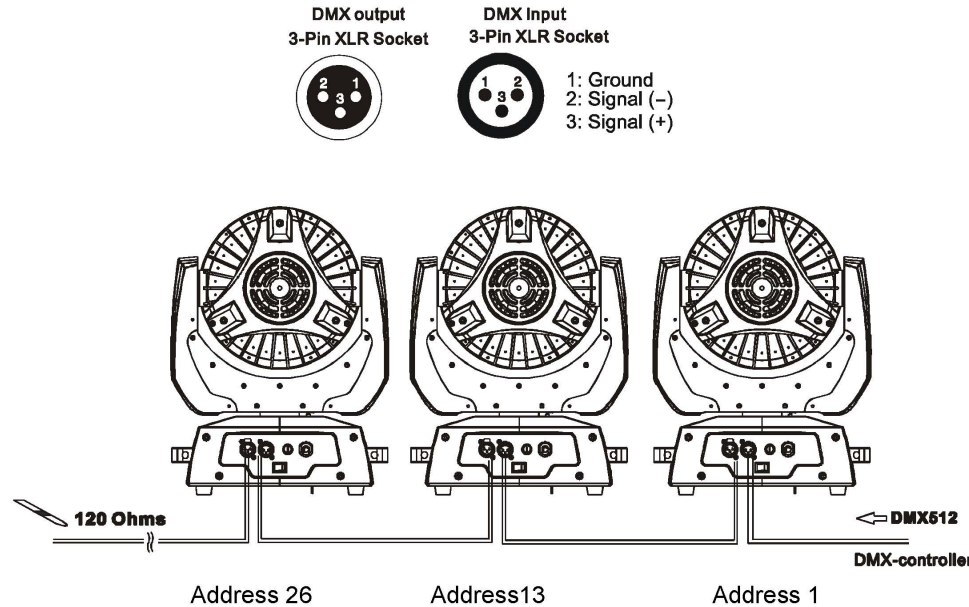

DMX-512 connection with DMX terminator

For installations where the DMX cable has to run a long distance or is in an electrically noisy environment, such as in a discotheque, it is recommended to use a DMX terminator. This helps in preventing corruption of the digital control signal by electrical noise. The DMX terminator is simply an XLR plug with a 120 Ω resistor connected between pins 2 and 3, which is then plugged into the output XLR socket of the last fixture in the chain. Please see illustrations below.

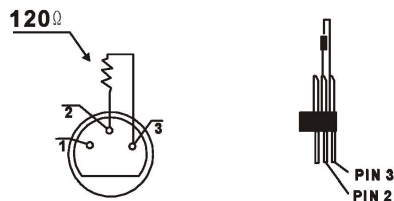

6. LCD Display Operations

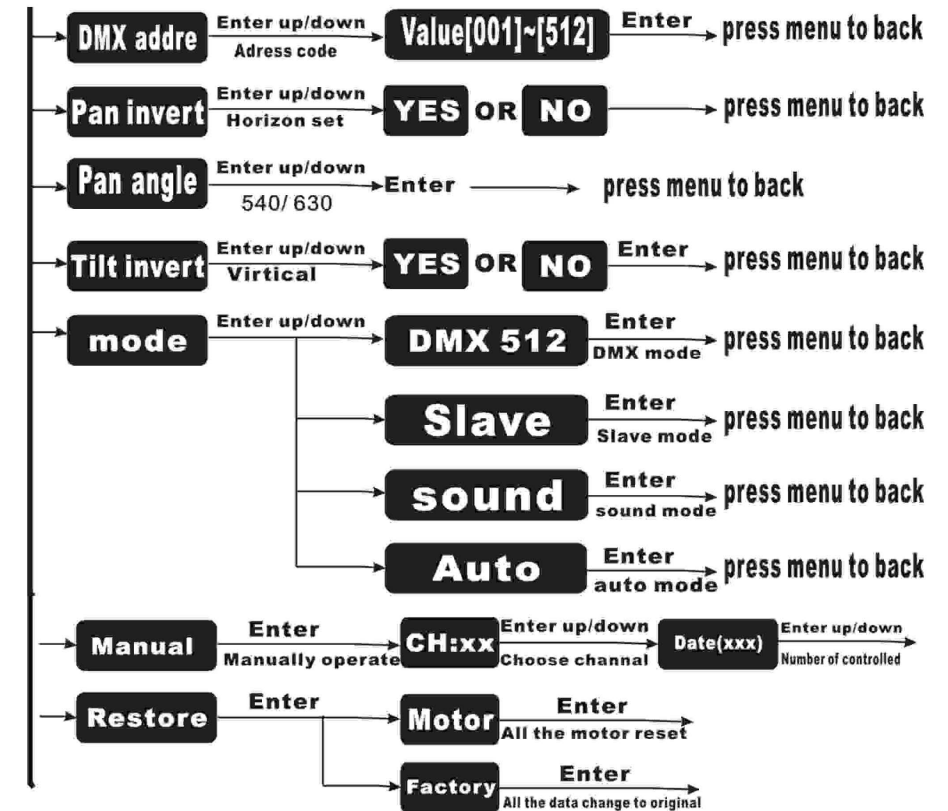

The display will close after 30 seconds without operations.