

Cyclo DMX

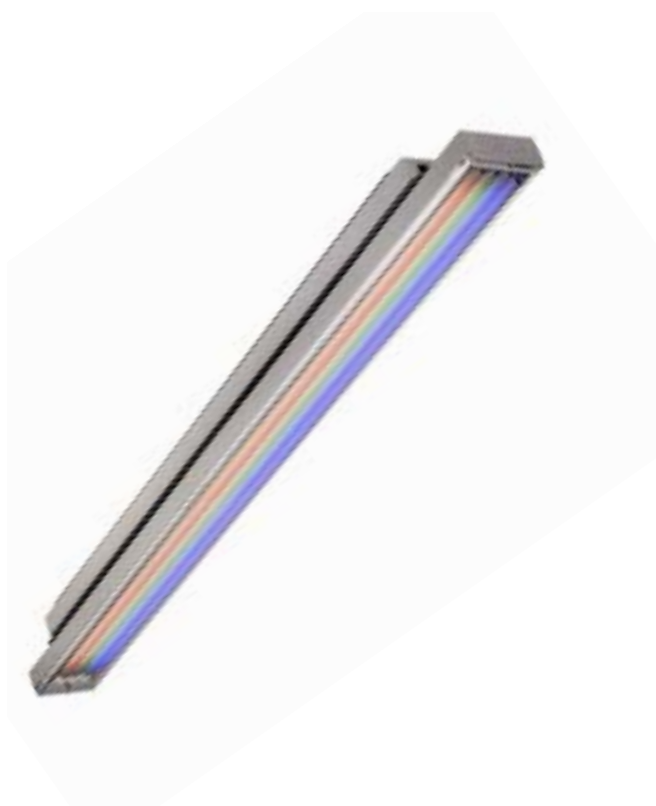

user manual

Measurements are in millimeters

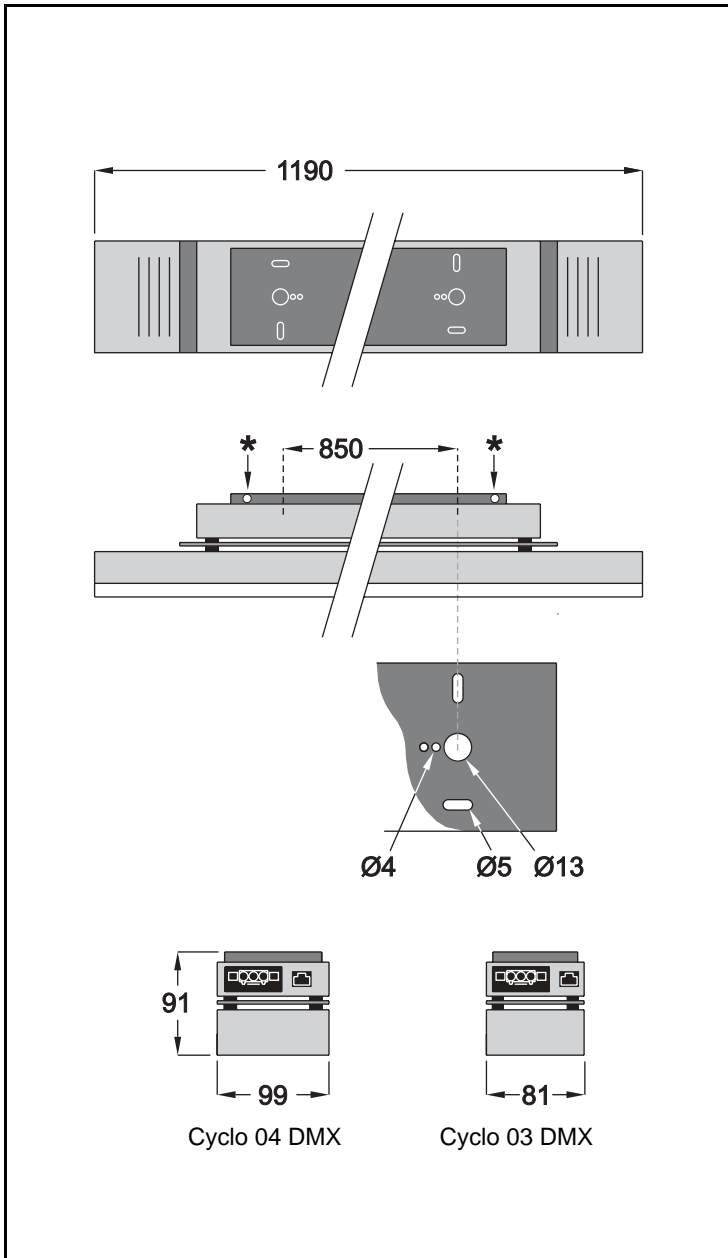

© 2003 Martin Professional A/S, Denmark.

All rights reserved. No part of this manual may be reproduced, in any form or by any means, without permission in writing from Martin Professional A/S, Denmark.

Printed in Denmark.

P/N 35000131, Rev B

- INTRODUCTION 4**
 - Safety information 4
- INSTALLATION 6**
 - AC power 7
 - Data linking multiple fixtures 8
 - Fluorescent tubes. 10
 - Cleaning 10
- STAND-ALONE OPERATION. 11**
 - Set the fixture to stand-alone operation 11
 - DIP-switch settings in stand-alone mode 12
 - Program selection 12
 - Master/slave 12
 - Program examples 14
- DMX OPERATION 16**
 - Connecting a DMX control device 16
 - Setting the fixture to DMX operation 16
 - Control address selection. 17
 - Intensity control 19
- DMX PROTOCOL. 20**
- SPECIFICATIONS - CYCLO DMX. 21**

INTRODUCTION

Thank you for selecting the Martin Cyclo DMX. The Cyclo DMX is a DMX-controllable, fluorescent color changer. This fixture is designed to be used for cove lighting, perimeter lighting, light walls, behind semi-transparent materials, or any place where room is restricted.

Cyclo DMX is a fixture based on dimmable fluorescent T5 tubes. The T5 tubes have achieved widespread popularity due to their design and high efficacy combined with their long lamp life.

Cyclo DMX control and power-cables are through-wired for easy installation.

The Cyclo DMX offers:

- Controllable RGB color-mixing
- Full 0-100% intensity control of the red, green, blue and white (Cyclo 04 only) tubes
- Bright output
- Long lamp life of 20,000 hours

Note: *It is important to read this manual through before you attempt to install this product.*

SAFETY INFORMATION

Warning! *This product is for professional use only. It is not for household use.*

These products present risks of lethal or severe injury due to fire and heat, electric shock and falls. **Read this manual** before powering or installing these fixtures, follow the safety precautions listed below and observe all warnings in this manual and on the fixtures. If you have questions about how to operate these fixtures safely, please contact your Martin dealer or call the Martin 24-hour service hotline at +45 70 200 201.

Protection from electric shock

- Disconnect the fixtures from AC power before removing or installing a lamp, fuses, or any part, and when not in use.
- Always ground (earth) the fixtures electrically.

- Use only a source of AC power that complies with local building and electrical codes and has both overload and ground-fault protection.
- Do not expose the fixtures to rain or moisture.
- Refer all service to a Martin service technician.

Protection from burns and fire

- Provide a minimum clearance of 0.1 meters (4 inches) around the fixture.
- Do not modify the fixture or install other than genuine Martin parts.
- Do not operate the fixture if the ambient temperature (T_a) exceeds 40° C (104° F).

Protection from injury due to falls

- Verify that all external covers and rigging hardware are securely fastened
- Block access below the work area whenever installing or removing the fixture.

INSTALLATION

This section describes in general terms how to install the fixture and connect it to AC and dimmer power. These procedures shall be performed by qualified professionals.

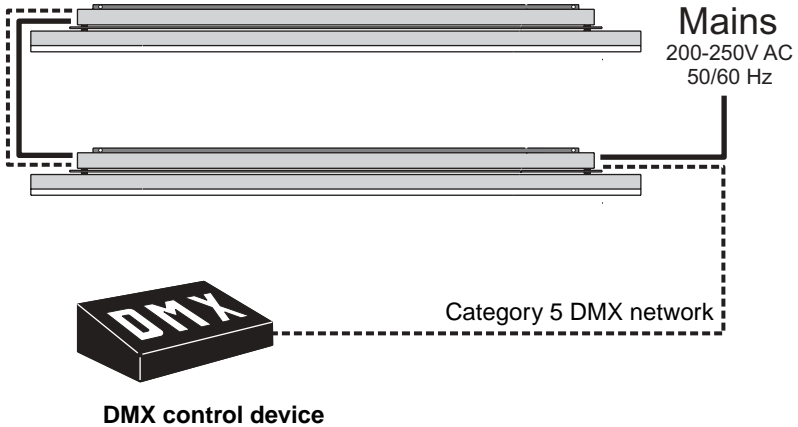

- To mount the fixture:
- 1 Loosen the two Philips screws holding the mounting plate to the fixture.

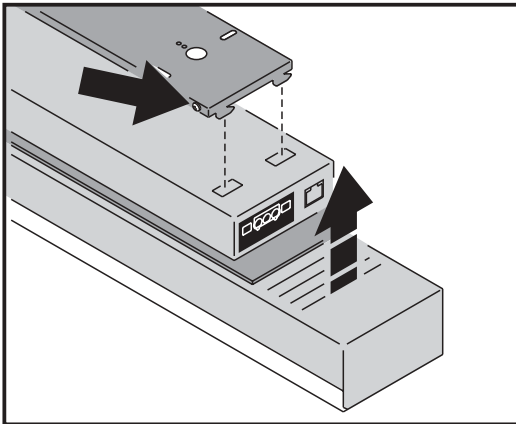

- 2 Remove the mounting plate from the fixture.

- 3 Fasten the mounting plate to the mounting surface using four 4 mm (1/6th in) mounting hardware that is able to bear the 6.7 kg (14.8 lbs) weight of the fixture.

To ensure adequate ventilation, we recommend that the Cyclo DMX be installed with a minimum of 25 mm (1 inch) of free space on each side. Screw the fixture into place using, either:

- 4 Reattach the fixture to the mounting plate and lock it into place by tightening the two Phillips screws on the side of the mounting plate.

AC POWER

Maximum power usage data for the Cyclo DMX is supplied in “Specifications - Cyclo DMX” on page 21.

Warning: *Cyclo DMX fixtures incorporate four electronic ballasts that “leak” a total of between 0.8-4mA of power. Because of this we recommend connecting a maximum of seven Cyclo DMX fixtures per phase on a 30mA HPFI circuit breaker.*

A normal 30 mA HPFI circuit breaker normally trips because of a current fault or leakage of approximately 20mA. It is important that the installation is carried out correctly in order to avoid unintentional tripping of the circuit breaker.

Many installations use common neutral leads in branch circuit distribution boxes. It is important that the neutral lead in the cable is connected to the same HPFI circuit breaker, that it is not connected to the neutral leads from other HPFI circuit breakers. The neutral lead must be only associated with that specific circuit breaker. Additionally it is important that the fixtures are connected correctly to the ground (earth) to ensure that the power leakage is able to run off.

You can power Cyclo DMX fixtures by wiring them in series. The internal wiring of the fixtures carries AC power through the fixture. Male and female Ensto connectors are provided at opposite ends of the fixture for input and output cables. AC power is connected into the fixture via the female

EnstoNet Installation System socket and out (to the next fixture) via the male socket at the other end of the fixture.

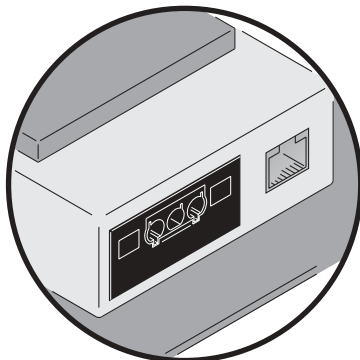

Power cabling and connectors are not supplied with the Cyclo DMX but cabling and connectors in a range of configurations can be ordered from your local Ensto distributor, or the following connectors and cables are available from your Martin dealer:

- ENSTO 3 pole 16A/250V male connector P/N 05347202
- ENSTO 3 pole 16A/250V female connector P/N 05327202
- ENSTO male/female cable (15 cm/5.9in.) P/N 11501019

Be sure to refer and comply with local standards. Some common AC cable configurations are:

Wire (EU)	Wire (US)	Pin	Marking
brown	black	live	“L” or “1”
blue	white	neutral	“N”
yellow/green	green	ground	⏏

Cyclo DMX fixtures can be powered in series with other Cyclo DMX fixtures of the same type. When doing this be sure to use a power cable that is able to handle the 0.56A that is drawn by each fixture in the series.

Data linking multiple fixtures

You need to create a data link if you are going to be:

- Operating multiple Cyclo DMXs in a synchronous way using the stand-alone functionality
- Controlling more than one fixture via a DMX control device

Creating a data link

The data transmission rate (250 kbits/s) used by DMX512 requires the selection of a cable which does not significantly distort the signal or give rise to spurious signal reflections. Cables intended for use with audio systems (microphone cables), while having the convenience of flexibility, availability and relative low cost, are NOT suitable for use with DMX512 because of their high capacitance and incorrect characteristic impedance; at DMX512 data rates this will give rise to bit time distortion and signal reflections/overshoot.

Cabling systems shall provide a balanced, nominal 120 ohm terminated transmission line, and be made of cables with a characteristic impedance in the range 100-120 ohms. The following cabling accessories can be ordered from your Martin dealer:

- CAT5 network cables - 2 m (6.5 ft) x 50 pieces P/N 91611044
- CAT5 network cables - 5 m (16.4 ft) x 30 pieces P/N 91611045
- CAT5 network cables - 10 m (32.8 ft) x 15 pieces P/N 91611045
- Termination Plug RJ-45. P/N 91613028

Note: *Mixing cables of different impedances and other characteristics not isolated by buffers or other processing devices may affect system reliability.*

Always use solid or stranded shielded-twisted pair/foiled twisted pair (STP/FTP), 100 or 120 ohm cables that conform to ISO IEC 11801 category 5 or higher with RJ-45 connectors wired as follows

Pair	Wire #	Color	Function	DMX512 Pin
Pair 2	1	white / orange	data 1 +	DMX512 Pin 3
	2	orange	data 1 -	DMX512 Pin 2
Pair 3	3	white / green	data 2 +	DMX512 Pin 5
	4	green	data 2 -	DMX512 Pin 4
Pair 1	5	blue	Not assigned	
	6	white / blue	Not assigned	
Pair 4	7	white / brown	Signal Common (0 v)	DMX512 Pin 1
	8	brown	Signal Common (0 v)	DMX512 Pin 1
Shield			drain	

The minimum wire size is 0.2 mm (24 AWG) for runs up to 300 meters (1000 ft.) and 0.322 mm (26 AWG) for runs up 500 meters (1640 ft.). Your Martin dealer can supply the right cable in various lengths.

The: RJ-45 sockets in the Cyclo DMX are wired as follows - pins 7 & 8 to ground, pin 2 to signal - (cold), and pin 1 to signal + (hot).

Creating the data link

- 1 Connect the RJ-45 connector on the Cyclo DMX to the RJ-45 connector on the next Cyclo DMX.
- 2 Continue connecting fixtures output to input. Up to 32 devices may be connected on a serial link.
- 3 Terminate the link by inserting a an RJ-45 termination plug into the RJ-45 data output of the last fixture.

Warning *If you are using Stand-Alone programs (see “Stand-alone operation” on page 11) on multiple fixtures on a data link and you experience random “flicker” or other unexplained control problems, insert a female termination plug (P/N 91613018) into the IN socket of the first fixture.*

FLUORESCENT TUBES

Burning in new tubes

In order to obtain the full 20000 hour life time, new fluorescent tubes must be burned in for 100 hundred hours at full power.

Identifying tube positions

Tube positions are identified in the Cyclo DMX as follows:

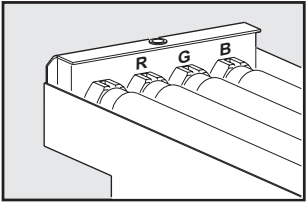
Marking in fixture	Marking on tube	Color	Reference illustration
R	OSRAM 28/60	Red	
G	OSRAM 28/66	Green	
B	OSRAM 28/67	Blue	
None (Cyclo 04 DMX only)	OSRAM 28/827 OSRAM 28/840 OSRAM 28/860	2700K white 4000K white 6000K white	

CLEANING

We recommend that you clean the dust cover with a damp cloth.

STAND-ALONE OPERATION

In stand-alone mode, individual Cyclo DMX fixtures can run a set of pre-programmed shows without an external controller. Multiple Cyclo DMX fixtures can also be linked together and scene changes on all fixtures can be synchronously triggered by a “master” fixture.

SET THE FIXTURE TO STAND-ALONE OPERATION

Stand-alone operation is enabled by setting pin 10 on the DIP switch to ON. The DIP switch can be accessed by loosening the cover access screw (do not remove it completely) and sliding open the access plate (as shown in the following illustration.)

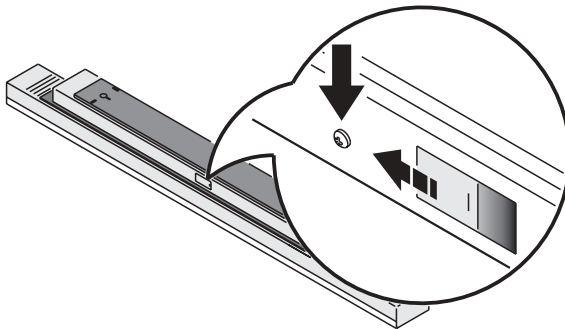

DIP-SWITCH SETTINGS IN STAND-ALONE MODE

Pin	Function															
1	White (in Cyclo 04 DMX) or not used (in Cyclo 03 DMX)															
2	Red															
3	Green															
4	Blue															
5 & 6	Program speed															
	<table border="1"><thead><tr><th>Pin 6</th><th>Pin 5</th><th>Speed</th></tr></thead><tbody><tr><td>Off</td><td>Off</td><td>Full speed (1 sec. pr. state)</td></tr><tr><td>Off</td><td>On</td><td>1/5 speed (5 sec. pr. state)</td></tr><tr><td>On</td><td>Off</td><td>1/10 speed (10 sec. pr. state)</td></tr><tr><td>On</td><td>On</td><td>1/30 speed (30 sec. pr. state)</td></tr></tbody></table>	Pin 6	Pin 5	Speed	Off	Off	Full speed (1 sec. pr. state)	Off	On	1/5 speed (5 sec. pr. state)	On	Off	1/10 speed (10 sec. pr. state)	On	On	1/30 speed (30 sec. pr. state)
Pin 6	Pin 5	Speed														
Off	Off	Full speed (1 sec. pr. state)														
Off	On	1/5 speed (5 sec. pr. state)														
On	Off	1/10 speed (10 sec. pr. state)														
On	On	1/30 speed (30 sec. pr. state)														
7	OFF = crossfade@0%, ON = crossfade@50%															
8	OFF = Run program, ON = Pause program															
9	OFF = Master, ON = Slave															
10	ON = Stand Alone mode.															

Table 1. DIP-switch settings in stand-alone mode

PROGRAM SELECTION

DIP-switch 1 to 4 each controls a single tube, and these DIP-switches can be combined to activate more than one tube. If DIP-switch 7 is set to OFF (crossfade @ 0%) then the tube will turn fully off before it fades in (or alternatively when more tubes are selected, the next tube will fade in).

If DIP-switch 7 is set to ON (crossfade @ 50%) the tube will only fade down to 50% before it fades to full again (or alternatively when more tubes are selected, the next tube will fade in when the first reach 100% and they “will meet” at 50%).

MASTER/SLAVE

When a fixture is set to master (DIP-switch pin 9 is off), it will transmit a synchronizing signal to slave fixtures over the data link whenever it changes to the next scene. Slave fixtures (DIP-switch pin 9 is set on) only change scenes when they receive synchronization signals from the master fixture.

The slave program will be as set by its DIP-switch, so to have a master and a slave run the same program, their DIP-switch settings have to be the same (apart from the Master/Slave setting).

The synchronization signal is the same as used by other Martin Architectural products, so this enables the stand-alone functionality to be used with a range of other Martin products.

To have a single fixture run alone, it must be set to master. Slave fixtures must not be connected to more than one master.

Advanced master/slave

To make more advanced schemes, it is important to understand how scenes are numbered. The scene pattern is always established in the sequence white to red to green to blue. This means that if white is enabled, it will always be placed first in the program. When crossfade @ 0% is selected, each color takes up two scenes (fade in and fade out). When crossfade @ 50% is selected, each color takes up one scene (fade in only). Scene numbering always starts at 0, and a maximum number of 8 scenes (0 - 7) can be set, with all colors enabled and crossfade@0%.

Each scene can be seen as a translation from one output to another, this translation is called a fade, and the time of the fade is set by the speed setting of the DIP-switch. When a fixture is in slave mode, each new fade is initiated by a synchronization signal received from the master. When the slave receives a synchronization signal, and initiates a fade, it will not act on new synchronization pulses, until the fade is complete.

If a slave fixture has:

- 1 Fewer scenes than the master fixture, it will run these in a cycle continuously, until the master fixture signals that the program should start from the beginning again.
- 2 More scenes than the master, then the additional scenes will never run, because the program will reset to the first scene when the master starts its program from the beginning.

Here is an example of what will happen when a slave fixture has fewer scenes than the master fixture:

	Scene pattern
Master with 7 scenes	01234560123456012...
Slave with 3 scenes	01201200120120012...

Example 4

DIP-switch 7 is set to ON = crossfade@50% and white and red is selected:

White	/	\	/	\	/	\	/	\	/	\	/	\
Red	\	/	\	/	\	/	\	/	\	/	\	/
Scene	0	1	2	3	0	1	2	3	0	1	2	3

Example 5

The rainbow effect is achieved by selecting, red, green, blue and DIP-switch 7 is set to ON = crossfade@50%.

Red	/	\	+	/	\	+	/	\	+	/	\	+
Green	+	/	\	+	/	\	+	/	\	+	/	\
Blue	\	+	/	\	+	/	\	+	/	\	+	/
Scene	0	1	2	0	1	2	0	1	2	0	1	2

DMX OPERATION

The Cyclo DMX may be programmed and operated with any lighting control device that is compatible with the USITT DMX standard. This section describes how to operate the system with a controller.

See “DMX protocol” on page 20 for specific control values.

Connecting a DMX control device

Connect a data cable from the Cyclo DMX to the control device’s data output. If the control device does not have an RJ-45 socket then you may need to purchase or wire an XLR-to-RJ45 converter. For wiring information see “Creating a data link” on page 9.

SETTING THE FIXTURE TO DMX OPERATION

DMX operation is enabled by setting pin 10 on the DIP switch to OFF. The DIP switch can be accessed by loosening the cover access screw (do not remove it completely) and sliding open the access plate (as shown in the following illustration.)

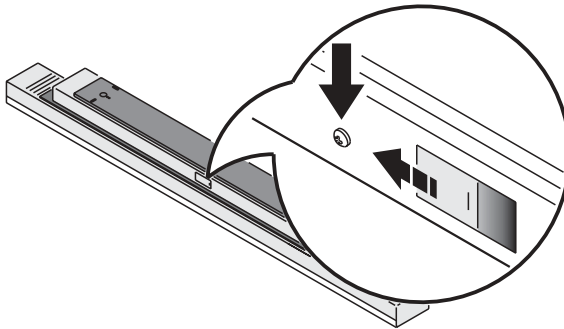

Control address selection

The Cyclo DMX requires 4 DMX control channels. The DMX address, also known as the start channel, is the first control channel used. It is a logical address to which control instructions are sent. In this way a controller, can send instructions to a fixture, or fixtures, at a particular address. For example when using four channels of control data, the Cyclo DMX reads the data on the start channel (DMX address) and the next three channels. If the DMX address is set to 100, the Cyclo DMX uses channels 100, 101, 102 and 103.

Be sure to allow adequate channels when setting the control address. If control channels for one fixture overlap control channels for another fixture, then one of the fixtures will receive the wrong commands. Two Cyclo DMXs may share the same address if they are to respond identically. They will receive the same commands and individual control will be impossible.

The default factory set control address is '1'.

Setting the DMX address

- 1 Select an address for the fixture on your controller. Look up the DIP switch setting for the address in the following table.
- 2 Set pins 1 through 9 ON (1) or OFF (0) as listed in the table.
- 3 Ensure that pin 10 is set to OFF.

Find the address in the table. Read the settings for pins 1 - 5 to the left and read the settings for pins 6 - 9 above the address. "0" means OFF and "1" means ON. Pin 10 is always OFF for DMX operation.

DIP switch Setting 0 = OFF 1 = ON					#9	0	0	0	0	0	0	0	0	1	1	1	1	1	1	1	1		
					#8	0	0	0	0	1	1	1	1	0	0	0	0	1	1	1	1	1	1
					#7	0	0	1	1	0	0	1	1	0	0	1	1	0	0	1	1	1	1
					#6	0	1	0	1	0	1	0	1	0	1	0	1	0	1	0	1	0	1
#1	#2	#3	#4	#5																			
0	0	0	0	0																			
1	0	0	0	0	1	32	64	96	128	160	192	224	256	288	320	352	384	416	448	480			
0	1	0	0	0	2	33	65	97	129	161	193	225	257	289	321	353	385	417	449	481			
1	1	0	0	0	3	34	66	98	130	162	194	226	258	290	322	354	386	418	450	482			
0	0	1	0	0	4	35	67	99	131	163	195	227	259	291	323	355	387	419	451	483			
1	0	1	0	0	5	36	68	100	132	164	196	228	260	292	324	356	388	420	452	484			
0	1	1	0	0	6	37	69	101	133	165	197	229	261	293	325	357	389	421	453	485			
1	1	1	0	0	7	38	70	102	134	166	198	230	262	294	326	358	390	422	454	486			
0	0	0	1	0	8	39	71	103	135	167	199	231	263	295	327	359	391	423	455	487			
1	0	0	1	0	9	40	72	104	136	168	200	232	264	296	328	360	392	424	456	488			
0	1	0	1	0	10	41	73	105	137	169	201	233	265	297	329	361	393	425	457	489			
1	1	0	1	0	11	42	74	106	138	170	202	234	266	298	330	362	394	426	458	490			
0	0	1	1	0	12	43	75	107	139	171	203	235	267	299	331	363	395	427	459	491			
1	0	1	1	0	13	44	76	108	140	172	204	236	268	300	332	364	396	428	460	492			
0	1	1	1	0	14	45	77	109	141	173	205	237	269	301	333	365	397	429	461	493			
1	0	0	0	1	15	46	78	110	142	174	206	238	270	302	334	366	398	430	462	494			
0	1	1	1	0	16	47	79	111	143	175	207	239	271	303	335	367	399	431	463	495			
1	0	0	0	1	17	48	80	112	144	176	208	240	272	304	336	368	400	432	464	496			
0	1	0	0	1	18	49	81	113	145	177	209	241	273	305	337	369	401	433	465	497			
1	1	0	0	1	19	50	82	114	146	178	210	242	274	306	338	370	402	434	466	498			
0	0	1	0	1	20	51	83	115	147	179	211	243	275	307	339	371	403	435	467	499			
1	0	1	0	1	21	52	84	116	148	180	212	244	276	308	340	372	404	436	468	500			
0	1	1	0	1	22	53	85	117	149	181	213	245	277	309	341	373	405	437	469	501			
1	1	1	0	1	23	54	86	118	150	182	214	246	278	310	342	374	406	438	470	502			
0	0	0	1	1	24	55	87	119	151	183	215	247	279	311	343	375	407	439	471	503			
1	0	0	1	1	25	56	88	120	152	184	216	248	280	312	344	376	408	440	472	504			
0	1	0	1	1	26	57	89	121	153	185	217	249	281	313	345	377	409	441	473	505			
1	1	0	1	1	27	58	90	122	154	186	218	250	282	314	346	378	410	442	474	506			
0	0	1	1	1	28	59	91	123	155	187	219	251	283	315	347	379	411	443	475	507			
1	0	1	1	1	29	60	92	124	156	188	220	252	284	316	348	380	412	444	476	508			
0	1	1	1	1	30	61	93	125	157	189	221	253	285	317	349	381	413	445	477	509			
1	1	1	1	1	31	62	94	126	158	190	222	254	286	318	350	382	414	446	478	510			
						63	95	127	159	191	223	255	287	319	351	383	415	447	479	511			

Table 2: DIP switch address settings



Channel 2



Channel 14



Channel 46



Channel 100

Address Setting Examples

INTENSITY CONTROL

The intensity of the individual colors can be set from minimum to maximum on channels 1 to 4.

Note ***Channel 1 is present, but not used, in Cyclo 03 DMX models.***

DMX PROTOCOL

Start code = 0

Channel	Value	Percent	Function
1 (not used for Cyclo 03 DMX)	0-2 3-252 253-255	0 1 - 99 100	White intensity Tube off Intensity 1→100% Intensity 100%
2	0-2 3-252 253-255	0 1 - 99 100	Red intensity Tube off Intensity 1→100% Intensity 100%
3	0-2 3-252 253-255	0 1 - 99 100	Green intensity Tube off Intensity 1→100% Intensity 100%
4	0-2 3-252 253-255	0 1 - 99 100	Blue intensity Tube off Intensity 1→100% Intensity 100%

SPECIFICATIONS - CYCLO DMX

PHYSICAL - CYCLO 04 DMX

L x W x H 1190 x 99 x 91 mm (50 x 3.9 x 3.6 in.)
Weight 6.7 kg (14.8 lbs)
Fixture color Grey

PHYSICAL - CYCLO 03 DMX

L x W x H 1190 x 81 x 91 mm (50 x 3.2 x 3.6 in.)
Weight 6.5 kg (14.3 lbs)
Fixture color Grey

INSTALLATION

Orientation any
Minimum free space around fixture when installed 25 mm (1 inch)

SOURCE

Approved lamp type OSRAM T5 FH 28 watt tubes
Light source T5 tubes (28W)
Expected lamp life 20000 hours

POWER

AC power 198 V - 254 V, 50 / 60 Hz
Maximum power and current @ 230 V / 50 Hz 0.56 A / 128 watts
AC input EnstoNet Installation System connector/plug (not supplied)

THERMAL

Maximum ambient temperature (T_a) 40° C (104° F)
Cooling convection

DYNAMIC EFFECTS

Dimmable tubes Red, green, blue and white (Cyclo 04 DMX only)
Independent dimming of each tube via DMX control device

CONTROL AND PROGRAMMING

Control options DMX512, stand alone, master/slave
Receiver RS-485
Setting and addressing DIP switch
Data input RJ-45
Data output RJ-45
DMX channels 4

ORDERING INFORMATION

Cyclo 04 DMX P/N 90550005
Cyclo 03 DMX P/N 90550015

INCLUDED ITEMS

Lamp.	OSRAM T5 FH28W/60 (red)
Lamp.	OSRAM T5 FH 28W/66 (green)
Lamp.	OSRAM T5 FH28W/67 (blue)
Lamp.	OSRAM T5 FH28W/840 (white) - (Cyclo 04 DMX only)
User manual	

ACCESSORIES

Diffuser front for Cyclo 04.	P/N 91611078
Diffuser front for Cyclo 03.	P/N 91611077
Termination Plug RJ-45.	P/N 91613028
ENSTO 3 pole 16A/250V male connector.	P/N 05347202
ENSTO 3 pole 16A/250V female connector.	P/N 05327202
RJ-45 connector (15 cm/ 5.9 in.).	P/N 11840088
ENSTO Male/female cable (15 cm/5.9in.).	P/N 11501019
XLR male to RJ-45 converter.	P/N 11840087
XLR female to RJ-45 connector.	P/N 11840086
CAT5 network cables - 2 m (6.5 ft) x 50 pieces.	P/N 91611044
CAT5 network cables - 5 m (16.4 ft) x 30 pieces.	P/N 91611045
CAT5 network cables - 10 m (32.8 ft) x 15 pieces.	P/N 91611045



www.martin-architectural.com • Olof Palmes Allé 18 • 8200 Aarhus N • Denmark
Tel: +45 8740 0000 • Fax +45 8740 0010