

---

**ROBE**

---

# Robin 300 Plasma Wash

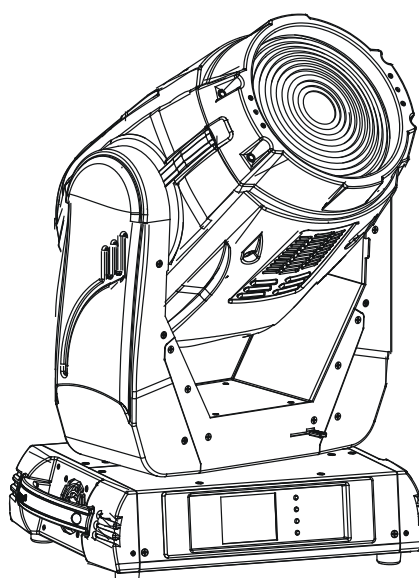

 **ROBIN**<sup>®</sup>  
Innovative Technology

---

## USER MANUAL

---

ROBE<sup>®</sup> Lighting s.r.o. • Czech republic • [www.robe.cz](http://www.robe.cz)

*Version1.5*

# Robin 300 Plasma Wash

## Table of contents

<b>1. Safety instructions</b> .....	<b>3</b>
<b>2. Operating determination</b> .....	<b>4</b>
<b>3. Fixture exterior view</b> .....	<b>5</b>
<b>4. Installation</b> .....	<b>6</b>
4.1 Placing the fixture head covers .....	6
4.2 Connection to the mains .....	6
4.3 Replacing the colour filters .....	7
4.4 Installing top hats .....	7
4.5 Rigging the fixture .....	8
4.6 DMX-512 connection.....	10
4.7 Ethernet connection .....	11
<b>5. Remotely controllable functions</b> .....	<b>13</b>
<b>6. Control menu map</b> .....	<b>14</b>
<b>7. Control menu</b> .....	<b>17</b>
7.1 Tab "Address" .....	18
7.2 Tab "Information" .....	18
7.3 Tab "Personality" .....	20
7.4 Tab "Manual Control" .....	21
7.5 Tab "Stand-alone" .....	22
7.6 Tab "Service".....	23
7.7 Icon "Lamp menu" .....	24
<b>8. RDM</b> .....	<b>25</b>
<b>9. Error and information messages</b> .....	<b>26</b>
<b>10. Technical Specifications</b> .....	<b>27</b>
<b>11. Maintenance and cleaning</b> .....	<b>29</b>

**CAUTION!**  
***Keep this device away from rain and moisture!***  
***Unplug mains lead before opening the housing!***

**FOR YOUR OWN SAFETY, PLEASE READ THIS USER MANUAL CAREFULLY  
BEFORE YOU INITIAL START - UP!**

## **1. Safety instructions**

Every person involved with installation and maintenance of this device have to:

- be qualified
- follow the instructions of this manual

**CAUTION!**  
***Be careful with your operations.***  
***With a high voltage you can suffer***  
***a dangerous electric shock when touching the wires!***

This device has left our premises in absolutely perfect condition. In order to maintain this condition and to ensure a safe operation, it is absolutely necessary for the user to follow the safety instructions and warning notes written in this manual.

### **Important:**

The manufacturer will not accept liability for any resulting damages caused by the non-observance of this manual or any unauthorized modification to the device.

Please consider that damages caused by manual modifications to the device are not subject to warranty.

Never let the power-cord come into contact with other cables! Handle the power cord and all connections with the mains with particular caution!

Make sure that the available voltage is not higher than stated on the rear panel.

Always plug in the power plug least. Make sure that the power-switch is set to off-position before you connect the device to the mains. The power plug has to be accessible after installing the device.

Make sure that the power-cord is never crimped or damaged by sharp edges. Check the device and the power-cord from time to time.

Always disconnect from the mains, when the device is not in use or before cleaning it. Only handle the power-cord by the plug. Never pull out the plug by tugging the power cord.

This device falls under protection class I. Therefore it is essential to connect the yellow/green conductor to earth.

The electric connection, repairs and servicing must be carried out by a qualified employee.  
Do not connect this device to a dimmer pack.

During the initial start-up some smoke or smell may arise. This is a normal process and does not necessarily mean that the device is defective.

Do not touch the device's housing bare hands during its operation (housing becomes hot)!  
For replacement use lamps and fuses of same type and rating only.

**CAUTION ! EYE DAMAGES !**  
***Avoid looking directly into the light source***  
***(meant especially for epileptics) !***

## 2. Operating determination

This device is a moving head for creating decorative effects and was designed for indoor use only.

If the device has been exposed to drastic temperature fluctuation (e.g. after transportation), do not switch it on immediately. The arising condensation water might damage your device. Leave the device switched off until it has reached room temperature.

Do not shake the device. Avoid brute force when installing or operating the device.

Never lift the fixture by holding it at the projector-head, as the mechanics may be damaged. Always hold the fixture at the transport handles.

When choosing the installation-spot, please make sure that the device is not exposed to extreme heat, moisture or dust. There should not be any cables lying around. You endanger your own and the safety of others!

The minimum distance between light output and the illuminated surface must be more than 1.5 meters.

Make sure that the area below the installation place is blocked when rigging, derigging or servicing the fixture.

Always fix the fixture with an appropriate safety rope. Fix the safety rope at the correct hole only.

Only operate the fixture after having checked that the housing is firmly closed and all screws are tightly fastened.

The maximum ambient temperature 40°C must never be exceeded.

**CAUTION!**  
***The lens has to be replaced when it is obviously damaged,  
so that its function is impaired, e. g. due to cracks or deep scratches!***

Operate the device only after having familiarized with its functions. Do not permit operation by persons not qualified for operating the device. Most damages are the result of unprofessional operation!

Please use the original packaging if the device is to be transported.

Please consider that unauthorized modifications on the device are forbidden due to safety reasons!

If this device will be operated in any way different to the one described in this manual, the product may suffer damages and the guarantee becomes void. Furthermore, any other operation may lead to dangers like short-circuit, burns, electric shock, crash etc.

### 3. Fixture exterior view

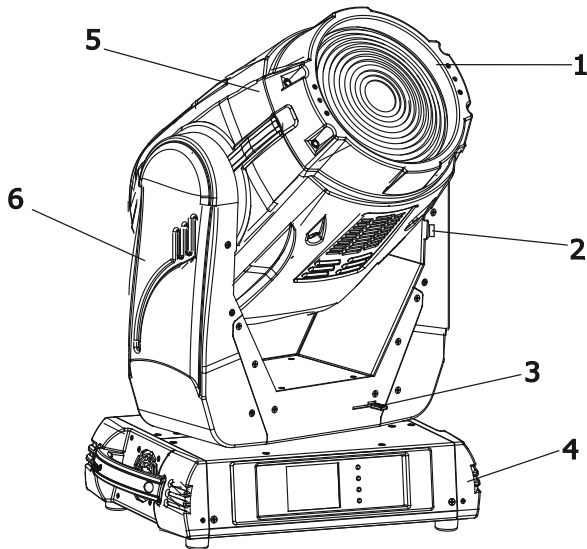

- 1 - Front lens
- 2 - Tilt lock
- 3 - Pan lock
- 4 - Base
- 5 - Moving head
- 6 - Arm

The head should be locked for transportation- the tilt lock latch (2) and the pan lock latch (3) have to be in the locked positions. To unlock the head, move these latches to unlock positions before operating the fixture.

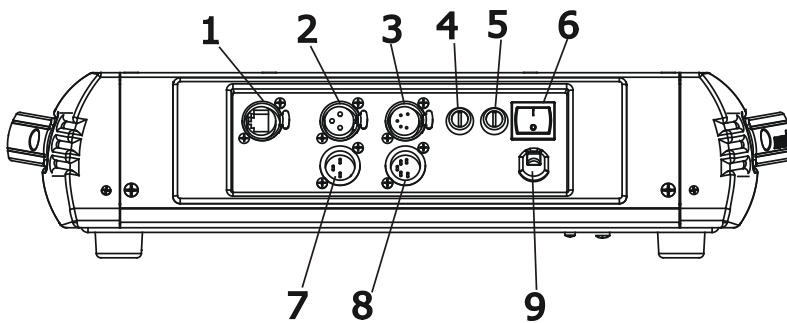

#### Rear panel of the base:

- 1 - Ethernet input-RJ45
- 2 - 3-pin DMX output
- 3 - 5-pin DMX output
- 4 - Fuse holder-neutral
- 5 - Fuse holder-live
- 6 - Power switch
- 7 - 3-pin DMX input
- 8 - 5-pin DMX input
- 9 - Power cord

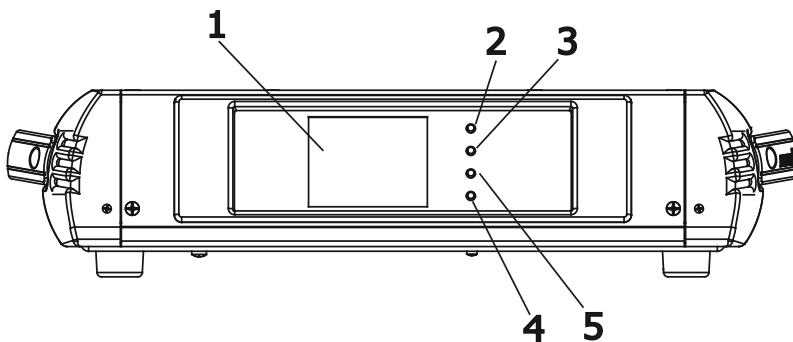

#### Front panel of the base:

- 1 - QVGA touch screen
- 2 - ESCAPE button
- 3 - NEXT button
- 4 - ENTER/DISPLAY ON button
- 5 - PREV button

The ENTER/DISPLAY ON button also serves for switching the display on when the fixture is disconnected from the mains.

## 4. Installation



**Fixtures must be installed by a Qualified electrician in accordance with all national and local electrical and construction codes and regulation.**

### 4.1 Placing the fixture head covers

The plastic head covers cannot be interchanged otherwise the fixture head will be overheated and the light source will be switched off. The rectangular array of air vents has to be over two axial fans.

**Pay attention to correct placing the covers on the head according to the following drawing:**

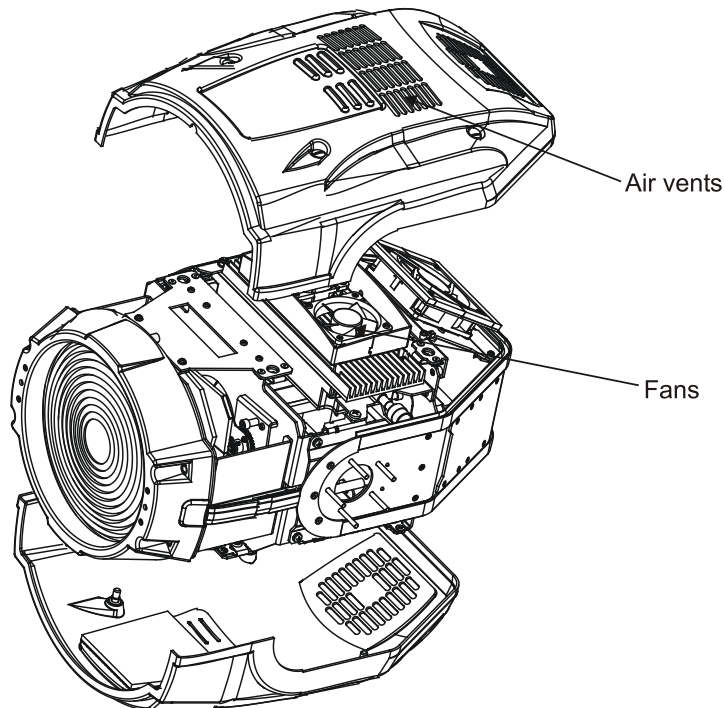

### 4.2 Connection to the mains

**For protection from electric shock, the fixture must be earthed!**

The Robin 300 Plasma Wash is equipped with auto-switching power supply that automatically adjusts to any 50/60Hz AC power source from 100-240 Volts.

Install a suitable plug on the power cord, note that the cores in the power cord are coloured according to the following table.

Core (EU)	Core (US)	Connection	Plug Terminal Marking
Brown	Black	Live	L
Light blue	White	Neutral	N
Yellow/Green	Green	Earth	

The earth has to be connected!  
If you have any doubts about proper installation, consult a qualified electrician.

### 4.3 Replacing the colour filters

**DANGER!**  
**Install the colour filters with the device switched off only.**  
**Unplug from mains before!**

#### Colour filters

1. Disconnect the fixture from mains and allow it to cool.
2. Remove the top plastic cover of the head by loosening the 4 quarter-turn fasteners on the cover.
3. Turn the colour wheel to the desired position. The dichroic filters are fixed on the colour wheel by the magnets.
4. Release the dichroic filter from the colour wheel by inclining it from its position to break the power of the magnet. Protect the glass filter with a piece of paper or clout.
5. Insert a new dichroic filter into the colour wheel.
6. Place the top cover back before applying power.

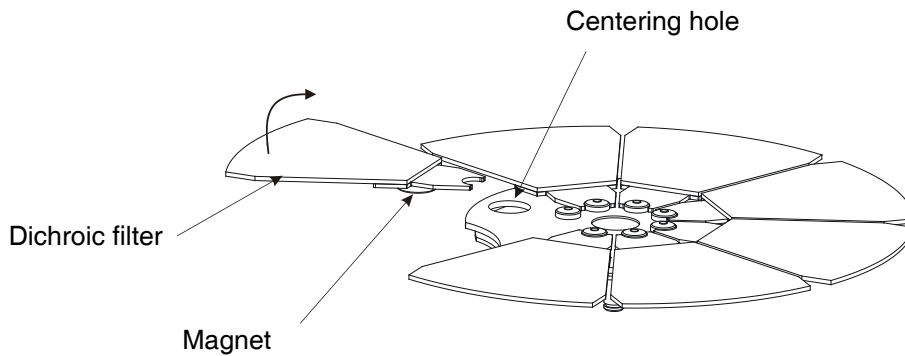

### 4.4 Installing top hats

The Robin 300 Plasma Wash can be fitted with various types of the top hats-see chapter the "Technical specifications". If you wish to install a top hat (optional), follow the instructions:

**Switch the device off before installing the top hat!**

1. Loosen 4 lens holder quarter-turn screws and hook both securing springs to the plastic projections in the front lens-holder. Tighten the 4 lens holder quarter-turn screws again.
2. Put desired top hat onto a front lens-holder and fasten it by two fastening screws.
3. Snap both springs to the slots in the top hat.

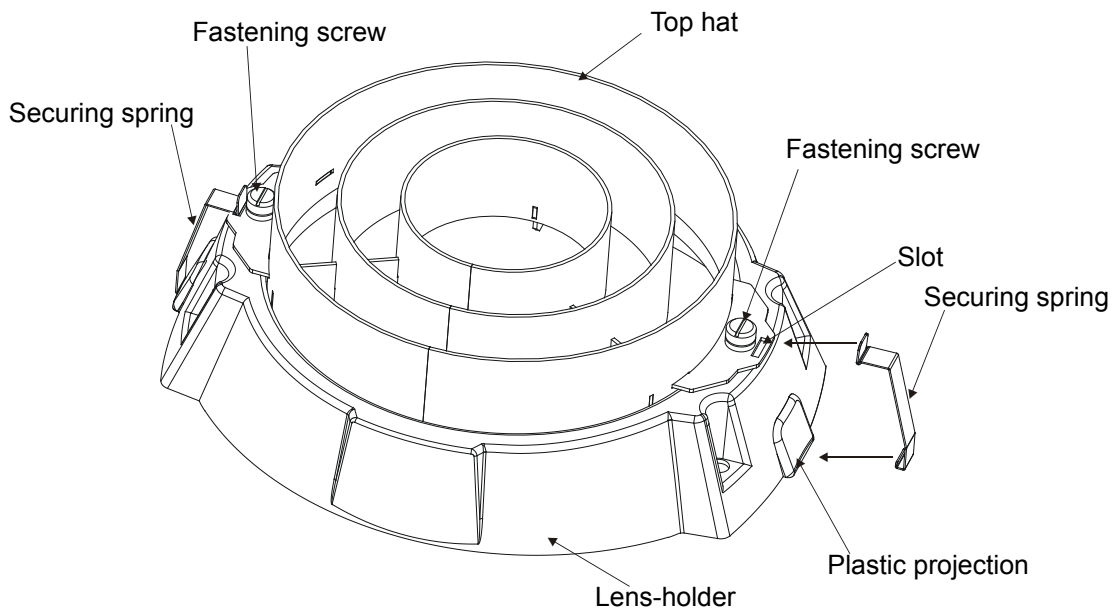

## 4.5 Rigging the fixture

The installation of the fixture has to be built and constructed in a way that it can hold 10 times the weight for 1 hour without any harming deformation.

The installation must always be secured with a secondary safety attachment, e.g. an appropriate catch net. This secondary safety attachment must be constructed in a way that no part of the installation can fall down if the main attachment fails.

When rigging, derigging or servicing the fixture staying in the area below the installation place, on bridges, under high working places and other endangered areas is forbidden.

The operator has to make sure that safety-relating and machine-technical installations are approved by an expert before taking into operation for the first time and after changes before taking into operation another time.

The operator has to make sure that safety-relating and machine-technical installations are approved by an expert after every four year in the course of an acceptance test.

The operator has to make sure that safety-relating and machine-technical installations are approved by a skilled person once a year.

The fixture should be installed outside areas where persons may walk by or be seated.

**IMPORTANT! OVERHEAD RIGGING REQUIRES EXTENSIVE EXPERIENCE**, including (but not limited to) calculating working load limits, installation material being used, and periodic safety inspection of all installation material and the projector. If you lack these qualifications, do not attempt the installation yourself, but instead use a professional structural rigger. Improper installation can result in bodily injury or damage to property. The fixture has to be installed out of the reach of people.

If the fixture shall be lowered from the ceiling or high joists, professional trussing systems have to be used. The fixture must never be fixed swinging freely in the room.

**Caution:** Fixture may cause severe injuries when crashing down! If you have doubts concerning the safety of a possible installation, do not install the moving head!

Before rigging make sure that the installation area can hold a minimum point load of 10 times the fixture's weight.

**Danger of fire !**  
**When installing the device, make sure there is no highly inflammable material (decoration articles, etc.) in a distance of min. 1 m.**

**CAUTION!**  
**Use 2 appropriate clamps to rig the fixture on the truss.**  
**Follow the instructions mentioned at the bottom of the base.**  
**Make sure that the device is fixed properly! Ensure that the structure (truss) to which you are attaching the fixtures is secure.**

The fixture can be placed directly on the stage floor or rigged in any orientation on a truss without altering its operation characteristics .

For securing a fixture to the truss install a safety wire that can hold at least 10 times the weight of the fixture. Use only safety wire with screw-on carabine. Pull the safety wire through the carrying handles and around the truss as shown on the pictures below.

Note: If the safety wire is too long, whip it several times around the truss in order to attach the fixture tight. In case of an accident, the way of the falling fixture will be short.



## Truss installation

1. Bolt each clamp (1) to the omega holder (3) with M12 bolt and lock nut through the hole in the holder.
2. Fasten the omega holders on the bottom of the base by inserting both quick-lock fasteners (4) into the holes of the base and tighten fully clockwise.
3. Pull the safety wire (2) through the carrying handles (5) and around the truss (6) as shown on the pictures below.

### Securing the fixture via one safety wire

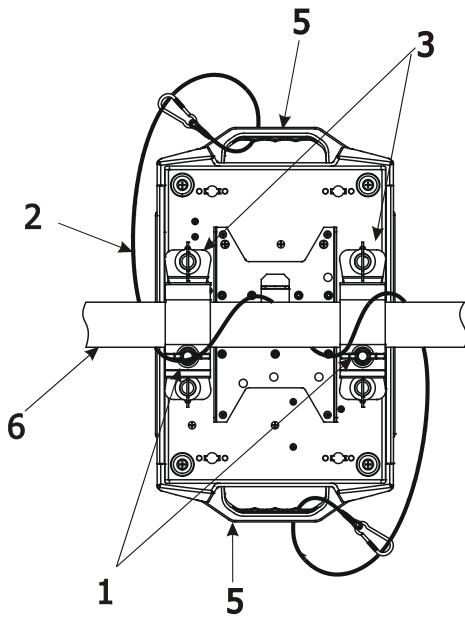

### Securing the fixture via two safety wires

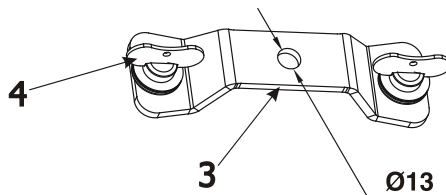
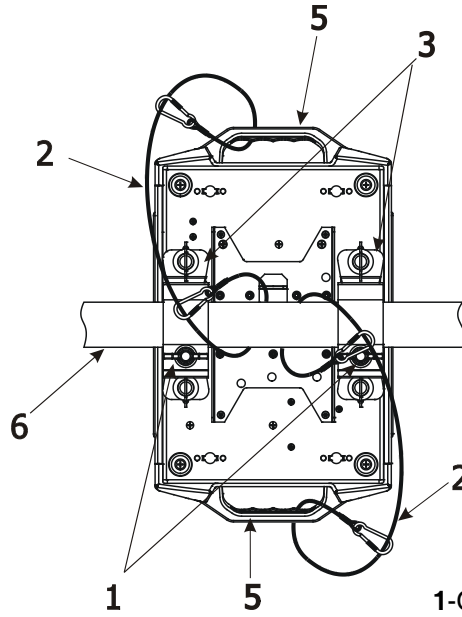

- 1-Clamps
- 2-Safety wire
- 3-Omega holder
- 4-Quick-lock fastener
- 5-Carrying handles
- 6-Truss

**When installing fixtures side-by-side,  
avoid illuminating one fixture with another!**

**DANGER TO LIFE!**  
**Before taking into operation for the first time, the installation has to be approved by an expert!**

## 4.6 DMX-512 connection

The fixture is equipped with both 3-pin and 5-pin XLR sockets for DMX input and output. The sockets are wired in parallel.

Only use a shielded twisted-pair cable designed for RS-485 and 3-pin or 5-pin XLR-plugs and connectors in order to connect the controller with the fixture or one fixture with another.

### DMX - output

XLR mounting-sockets (rear view):

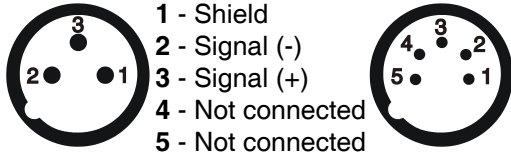

### DMX-input

XLR mounting-plugs (rear view):

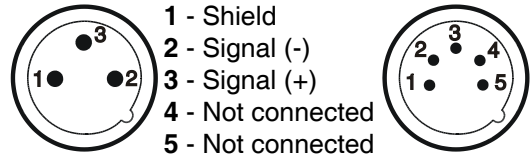

If you are using the standard DMX controllers, you can connect the DMX output of the controller directly with the DMX input of the first fixture in the DMX-chain. If you wish to connect DMX-controllers with other XLR-outputs, you need to use adapter-cables.

### Building a serial DMX-chain:

Connect the DMX-output of the first fixture in the DMX-chain with the DMX-input of the next fixture. Always connect one output with the input of the next fixture until all fixtures are connected.

**Caution:** At the last fixture, the DMX-cable has to be terminated with a terminator. Solder a 120  $\Omega$  resistor between Signal (-) and Signal (+) into a 3-pin XLR-plug and plug it in the DMX-output of the last fixture.

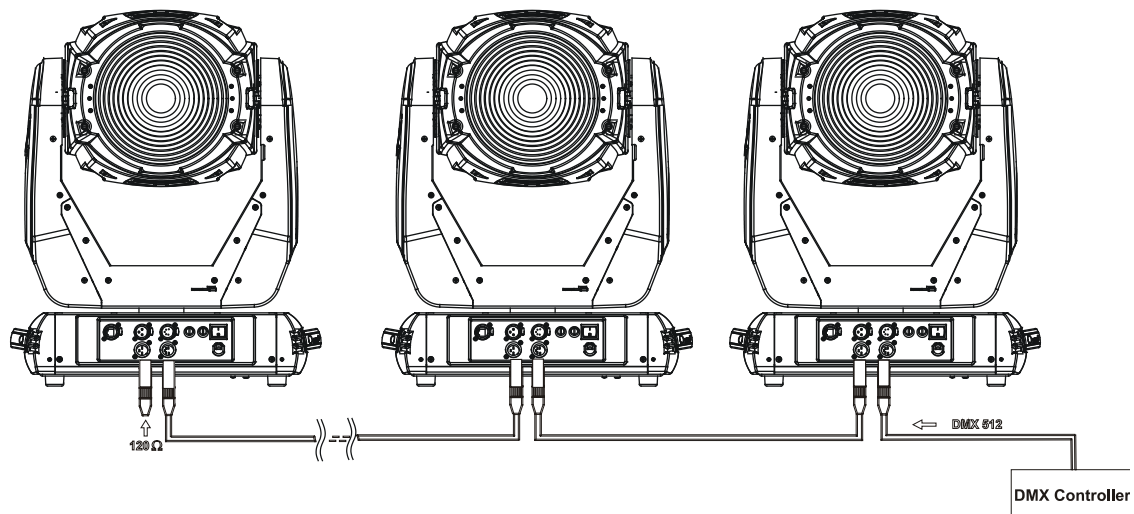

## 4.7 Ethernet connection

The fixtures on a data link are connected to the Ethernet with ArtNet communication protocol. The control software running on your PC (or light console) has to support Art-Net protocol.

Art-Net communication protocol is a 10 Base T Ethernet protocol based on the TCP/IP. Its purpose is to allow transfer of large amounts of DMX 512 data over a wide area using standard network technology.

**IP address** is the Internet protocol address. The IP uniquely identifies any node (fixture) on a network.

**The Universe** is a single DMX 512 frame of 512 channels.

The Robin 300 Plasma Wash is equipped with 8-pin RJ-45 socket for Ethernet input. Use a network cable category 5 (with four "twisted" wire pairs) and standard RJ-45 plugs in order to connect the fixture to the network.

**RJ-45 socket (front view):**

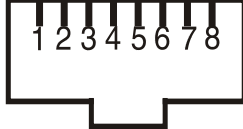

- |                  |                  |
|------------------|------------------|
| 1- TD+           | 5- Not connected |
| 2- TD-           | 6- RX-           |
| 3- RX+           | 7- Not connected |
| 4- Not connected | 8- Not connected |

**RJ-45 plug (front view):**

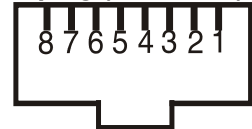

Patch cables that connect fixtures to the hubs or LAN sockets are wired 1:1, that is, pins with the same numbers are connected together:



If only the fixture and the computer are to be interconnected, no hubs or other active components are needed.

A cross-cable has to be used:



If the fixture is connected with active Ethernet socket (e.g. switch) the network icon  will appear at the bottom right corner of the screen:

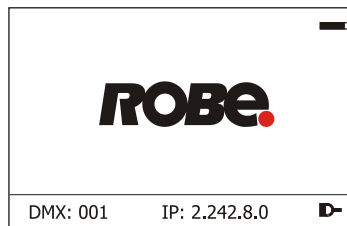

### Direct Ethernet operation

Connect the Ethernet inputs of all fixtures with the Ethernet network.

Option "Artnet/MaNet" has to be selected from "Ethernet Mode" menu on the fixture.

Set IP address (002.xxx.xxx.xxx / 010.xxx.xxx.xxx) and the Universe.

(DMX address=60)  
IP address=002.168.002.004  
Universe=1

(DMX address=20)  
IP address=002.168.002.003  
Universe=1

(DMX address=1)  
IP address=002.168.002.002  
Universe=1

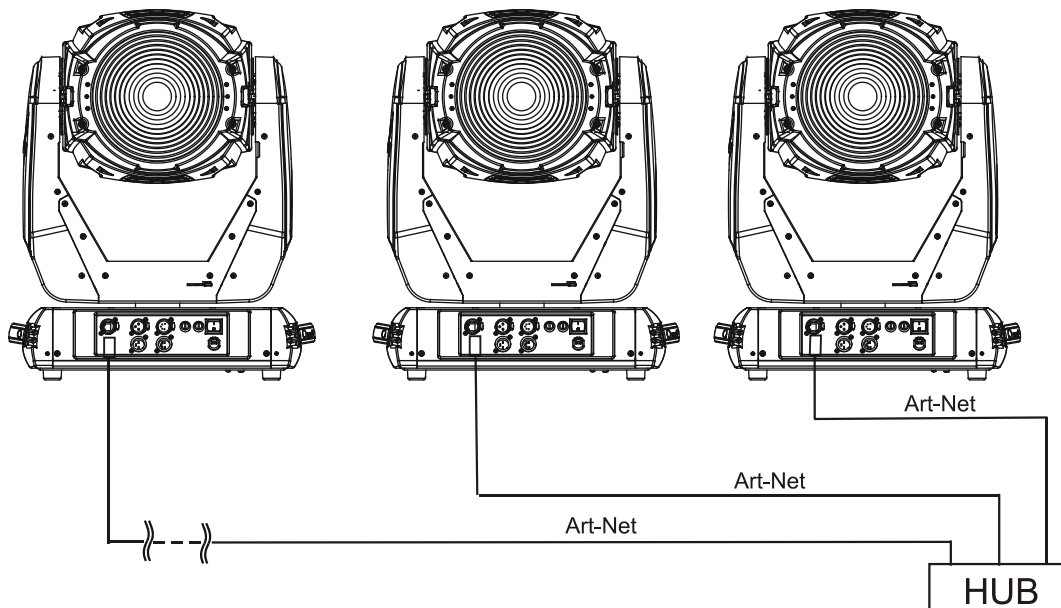

An advised PC setting: IP address: 002.xxx.xxx.xxx / 010.xxx.xxx.xxx (Different from fixture IP addresses)  
NET mask: 255.0.0.0

## Ethernet / DMX operation

Options "Ethernet/DMX" has to be selected from the "Ethernet Mode" menu on the first fixture (connected to the Ethernet) in the fixture chain, next fixtures have standard DMX setting.

Connect the Ethernet-input of the first fixture in the data chain with the network. Connect the DMX output of this fixture with the input of the next fixture until all fixtures are connected to the DMX chain.

**Caution:** At the last fixture, the DMX chain has to be terminated with a terminator. Solder a 120 Ω resistor between Signal (-) and Signal (+) into a XLR-plug and connect it in the DMX-output of the last fixture.

Example:

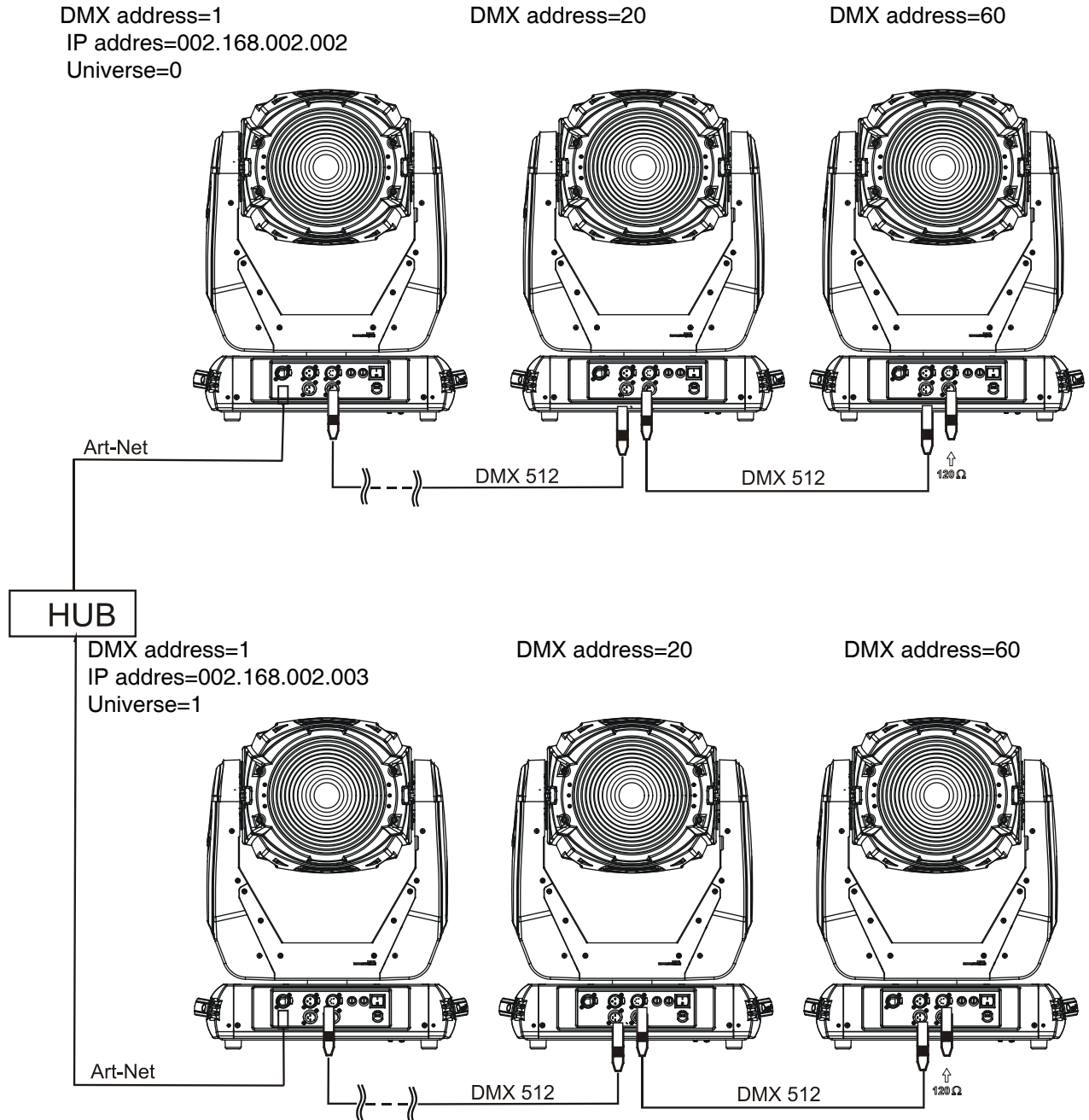

## 5. Remotely controllable functions

### Lamp

The LIFI™ ENT 31-02 is a category of solid-state lighting. LIFI™ like a electrodeless lighting technology does not require electrodes to power the bulb and therefore has a completely sealed, contaminant free and long lasting bulb. The LIFI™ light source uses a solid-state device to generate radio frequency energy to power a plasma light source. LIFI™ is able to combine the reliability of the solid-state technology with the high brightness and full spectrum of high-intensity discharge sources.

### Colour wheel

This wheel contains 7 replaceable 'SLOT&LOCK' dichroic filters + open. The colour wheel can be positioned between two adjacent colours in any position. It is also possible to rotate the colour wheel continuously at different speeds ("Rainbow effect" in both directions).

### CMY+CTO colour mixing system

The CMY color mixing system is based on graduated cyan, magenta, and yellow colour filters. A continuous range of colors may be achieved by varying the amount of each filter from 0 to 100%.

Colour temperature correction filter lowers the colour temperature from 6000 K to 3200 K.

Note: After 1500 operating hours the colour temperature will settle on 6550K.

### Zoom

Motorized zoom unit enables zoom between 10° and 35° beam angle.



### Dimmer/Shutter unit

Smooth 0 - 100 % dimming is provided by the mechanical dimmer /shutter unit. This unit is also used for strobe effects with variable speed.

## 6. Control menu map

Default settings=**Bold print**

Tab	Level 1	Level 2	Level 3	Level 4	Level 5	Level 6
Addressing	Settings	DMX Address	001-255			
		Ethernet Settings	Ethernet Mode	Disable		
				ArtNet/MaNet		
				Ethernet To DMX		
			IP Address/Net Mask	Default IP Address		
				Custom IP Address		
				Net Mask		
			ArtNet Universe	0-255		
			MANet settings	MANet Universe		
				MANet Session ID		
Information	Fixture Times	Power On Time	Total Hours			
			Resetable Hours			
		Lamp On Time	Total Hours			
			Resetable Hours			
		Lamp Strikes	Total Strikes			
			Resetable Strikes			
		Air Filters	Elapsed Time			
			Alert Period	10-300		
	Fixture Temperatures	Head Temperature	Current			
			Maximum NonRes.			
			Maximum Res.			
		Driver Temperature	Current			
			Maximum NonRes.			
			Maximum Res.			
		Base Temperature	Current			
			Maximum NonRes.			
			Maximum Res.			
	DMX Values	Pan				
		:				
		Dimmer Fine				
	Software Versions	Display System				
		Module M				
		Module C1				
		Module C2				
	Product IDs	Mac Address				
		RDM UID				
		RDM Label				
	View Logs	Fixture Errors	Pan Errors			
			:			
			Temp.Sensor Errors			
		Fixture Status	Power On			
			Power Off			
			Lamp On			
			Lamp Off			
		Fixture Position				
		Fixture Temperatures	Head Temperatures			
			Driver Temperatures			
			Base Temperatures			

Tab	Level 1	Level 2	Level 3	Level 4	Level 5	Level 6
Personality	User Mode	User A Settings				
		User B Settings				
		User C Settings				
	DMX Presets	<b>Mode 1</b>				
		Mode 2				
		Mode 3				
		View Selected Preset				
	Pan/Tilt Settings	Pan Reverse	Off, On			
		Tilt Reverse	Off, On			
		Pan/Tilt Feedback	Off, On			
		Pan/Tilt mode	Time			
			<b>Speed</b>			
	Microphone Sensitivity	1-10-20				
	Blackout Settings	Blackout During M.C.	Off, On			
		Blackout while:	Pan/Tilt moving	Off, On		
			Colour Wheel Moving	Off, On		
	Init Effect Positions	Pan	0-255			
		:				
		Dimmer Fine	0-255			
	Screen Settings	Display Intensity	1-10			
		Screen Saver Delay	Off-10min.			
		Touchscreen Lock	Off-10min.			
		Recalibrate Touchscreen				
		Display Orientation	Normal			
			Inverted			
			<b>Auto</b>			
	Temperature Unit	°C, °F				
	Fan Mode	<b>Auto</b>				
		High				
	Date & Time Settings					
	Default Settings					
Manual Control	Reset Functions	Reset All Systems				
		Pan/Tilt reset				
		Colour System Reset				
		Strobe Reset				
		Optics Reset.				
		Iris Reset				
	Preset Effect Control	Pan	Position 1-Position 5			
		:				
		Dimmer	Position 1- Position 5			
	Manual Effect Control	Pan	0-255			
		:				
		Dimmer Fine	0-255			
Stand -Alone	Test Sequences	Dynamic Mode				
		Static Mode	Pan	0-255		
			Tilt	0-255		
			Zoom	0-255		
	MusicTrigger	Off, On				
	Preset Playback	<b>None</b>				
		Test				
		Prg. 1				
		Prg. 2				

Tab	Level 1	Level 2	Level 3	Level 4	Level 5	Level 6
		Prg. 3				
	Play Program	Play Program 1				
		Play Program 2				
		Play Program 3				
	Edit Program	Edit Program 1	Start Step	1-100		
			End Step	1-100		
			Edit Program Steps	Step 1	Pan (0-255)	
				:	:	
				:	Dimmer Fine (0-255)	
				:	Step Time (0-25.5s)	
				Step 100	Pan (0-255)	
					:	
					Dimmer Fine (0-255)	
					Step Time (0-25.5s)	
Service	Adjust DMX Values	Pan	0-255			
		:				
		Dimmer Fine	0-255			
	Adjust Lamp	Pan	0-255			
		Tilt	0-255			
		Zoom	0-255			
	Calibrations	Calibrate Effects	Pan	0-255		
			Tilt	0-255		
			Colour Wheel	0-255		
			Colour Wheel Fine	0-255		
		Load Default Calibrations				
	Update Software					



## 7. Control menu

The Robin 300 Plasma Wash Light is equipped with the QVGA Robe touch screen with battery backup which allows to set the fixture's behaviour according to your needs, obtain information on its operation, test its various parts and lastly program it, if it has to be used in a stand-alone mode.

The fixture's menu can be controlled either by the control buttons or directly by touching the icon.

### Control buttons on the front panel:

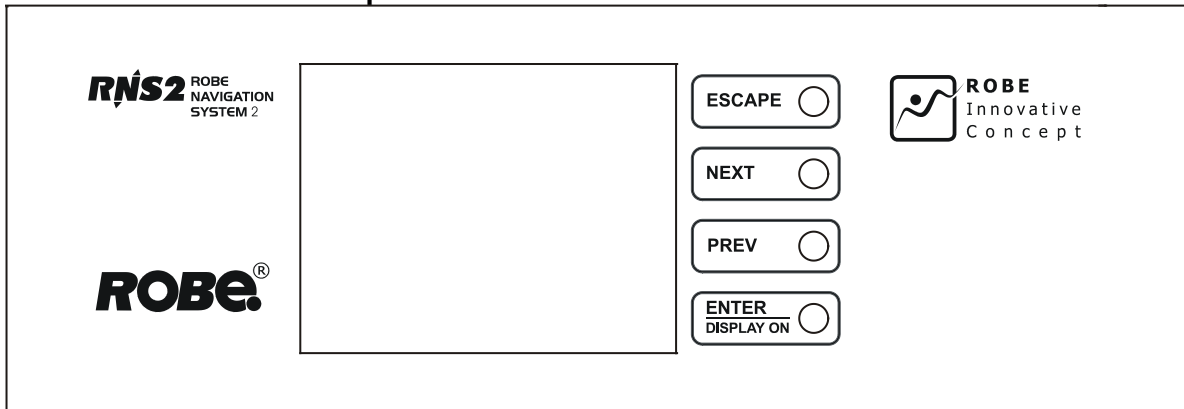











[ESCAPE] button used to leave the menu without saving changes.

[NEXT] , [PREV] buttons for moving between menu items and symbols, adjusting values.

[ENTER/Display On] button used to enter the selected menu (menu item) and to confirm adjusted value.

**If the fixture is disconnected from mains, the button switches the touch screen on.**

### Icons used in the touch screen menu:

-  - [back arrow] used to move back to the previous screen (menu).
-  - [up arrow] used to move up on the previous page.
-  - [down arrow] used to move down on the next page.
-  - [confirm] used to save adjusted values, to leave menu or to perform desired action.
-  - [cancel] used to leave menu item without saving changes.
-  - [confirm+copy] used to save adjusted values and copy them to the next prog. step.
-  - [warning icon] used to indicate some error which has occurred in the fixture.
-  - [lamp menu] used to switch on/off the lamp and to set lamp functions.
-  - [Ethernet] used to indicate Ethernet connected.
-  - [display turn] used to turn the display by 180°.

The menu page displays icons for each function that you can perform from the touch screen.

After switching the fixture on, the touch screen shows the screen with the ROBE logo:

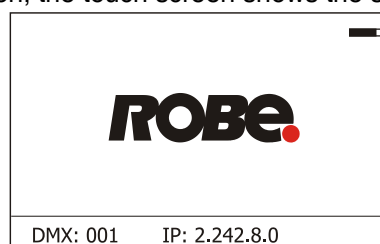

The green icon at the top right corner of the screen indicates the level of the display battery charging. If the whole icon is green, the battery is fully charged while the red icon indicates exhausted battery. The battery charges during fixture operation.

Touch any part of the screen or press the [ENTER/Display On] button to display the initial screen with the current stored DMX address:

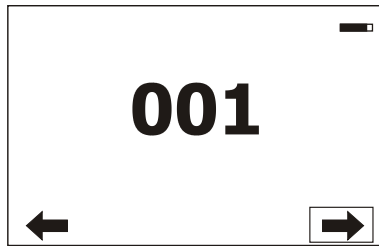

Touch the green arrow at the bottom right corner of the screen or press the [ENTER/Display On] button to enter the " Address" menu.

An item (such as a Tab, menu item, text box, icon) may be selected from a screen by simply touching the item in the list or by pressing the [NEXT] or [PREV] buttons to scroll through list items. With each press, the next item is highlighted. Press [ENTER/Display On] to select the highlighted item.

**Before first fixture operation, set current date and time in the menu "Date &Time Settings" (menu path: Personality--> Date &Time Settings).**

## 7.1 Tab " Address"



**Settings** - Select the menu to set desired fixture address setting.

**DMX Address** - Select the menu to set the DMX start address.

**Ethernet Settings** - The menu allows all needed settings for the Ethernet operation

**Ethernet Mode** - Use the menu to set the Ethernet operation mode:

**Disable** - The option disables Ethernet operation.

**Artnet/MaNet** - Fixture receives Artnet protocol (or MANet) - every fixture has to be connected to the Ethernet network.

**Ethernet To DMX** - Fixture receives Artnet protocol from the Ethernet input and sends DMX data to its DMX output (fixture works as an "Artnet/DMX converter", next fixture can be connected to its DMX output and you can build a standard DMX chain by connecting another fixtures. Only one fixture has to be connected to the Ethernet.

**IP Address/Net Mask** - Select this menu to set IP address. IP address is the Internet protocol address. The IP uniquely identifies any node (fixture) on a network. There cannot be 2 fixtures with the same IP address on the network!

**Default IP Address** -Preset IP address, you can set up only first byte of IP address (2 or 10) e.g. **002**.019.052.086.

**Custom IP Address** - The option enables to set up all bytes of IP address.

**Net Mask** - The option enables to set up all bytes of Net Mask.

**ArtNet Universe** - Use this item to set a Universe (0-255). The Universe is a single DMX 512 frame of 512 channels.

**MANet Settings** - Use this menu to set parameters for MANet operation.

**MANet Universe** - The value of this item can be set in range 1-64.

**MANet Session ID** - The value of this item can be set in range 1-32.

## 7.2 Tab "Information"



**Fixture Times** - The menu provides readouts of fixture and lamp operation hours.

**Power On Time Hours** - Select this menu to read the number of fixture operation hours.

**Total Hours** - The item shows the total number of the operation hours since the Robin 300 Plasma Wash has been fabricated.

**Resetable Hours** - The item shows the number of the operation hours that the Robin 300 Plasma Wash has been powered on since the counter was last reset. In order to reset this counter to 0, touch the text box next to the item "Resetable Hours:"

**Lamp On Time Hours** - Select this menu to read the number of the operation hours with the lamp on.

**Total Hours** - The item shows the total number of the operation hours with the lamp on since the Robin 300 Plasma Wash has been fabricated.

**Resetable Hours** - The item shows the number of the operation hours with the lamp on that the Robin 300 Plasma Wash has been powered on since the counter was last reset. In order to reset this counter to 0, touch the text box next to the item "Resetable Hours:"

**Lamp Strikes** - Select this menu to read the number of lamp strikes.

**Total Strikes** - The item shows the total number of the lamp strikes since the Robin 300 Plasma Wash has been fabricated.

**Resetable Strikes** - The item shows the number of the lamp strikes since the counter was last reset.

In order to reset this counter to 0, touch the text box next to the item "Resetable Strikes:"

**Fixture Temperatures** - The menu is used to view temperatures of the fixture's inside.

**Head Temperature** - The menu shows temperatures in the fixture head near the lamp.

**Current** - A current temperature of the fixture head.

**Maximum NonRes.** - A maximum temperature of the fixture head since the fixture has been fabricated.

**Maximum Res.** - A maximum temperature of the fixture head since the counter was last reset.

In order to reset this counter to 0, touch the text box next to the item "Maximum Res."

**Note:** if the "Head Temperature" exceeds 85°C, the lamp will be switched off.

**Driver Temperature** - The menu shows temperature of the plasma source driver in the fixture head.

**Current** - A current temperature of the driver.

**Maximum NonRes.** - A maximum temperature of the driver since the fixture has been fabricated.

**Maximum Res.** - A maximum temperature of the driver since the counter was last reset.

In order to reset this counter to 0, touch the text box next to the item "Maximum Res."

**Base Temperature** - The menu shows temperature in the fixture base (on the display PCB).

**Current** - A current temperature in the fixture base.

**Maximum NonRes.** - A maximum temperature in the fixture base since the fixture has been fabricated.

**Maximum Res.** - A maximum temperature in the fixture base since the counter was last reset.

In order to reset this counter to 0, touch the text box next to the item "Maximum Res."

**Air Filters** - Regular cleaning of the air filters is very important for the fixture's life and performance.

Build-up of dust, dirt and fog fluid residues reduces the fixture's light output and cooling ability.

The two items of this menu help you to keep cleaning period of the air filters.

**Alert period** - Cleaning schedule for the fixture depends on the operating environment.

It is therefore impossible to specify accurate cleaning interval. This item allows you to change the cleaning interval of the air filters. This "alert" value is 300 hours and it is set as default. Inspect the fixture within its 300 hours of operation to see whether cleaning is necessary. If cleaning is required, clean all air filters and change the value in this menu on acceptable level. Min. level of alert period is 10 hours, max. is 300 hours.

**Elapsed Time** - The item allows you to read the time which remains to cleaning air filters.

The time period is set in the menu mentioned above.

Expired time period is signalled by a negative mark (-) at the time value and a warning icon on the display.

Clean the filters and reset this menu item (by touching the text box next to the item "Elapsed Time").

**DMX Values** - The menu is used to read DMX values of each channel received by the fixture.

**Software Version** - Select this item to read the software version of the fixture modules:

**Display System** - A display processor on the display board in the fixture base

**Module M** - A pan/Tilt processor on the main board in the fixture arm

**Module C1** - A strobe/Magenta/Yellow/Zoom1 processor on the board in the fixture head.

**Module C2** - A CMY+CTO/colour/dimmer/frost 2 processor on the board in the fixture head.

**Product IDs** - The menu is used to read the MAC Address ,RDM UID and RDM Label.

**View Logs** - Use this menu to read fixture's data which have been recorded during fixture operation. This collected data allows easier troubleshooting.

**Fixture Errors** - Use this menu to read fixture errors which have occurred during fixture operation.

There is a list of error folders:

Pan Errors

Tilt Errors

Dimmer 1 Errors

Dimmer 2 Errors

Colour Errors

HotSpot Errors

Iris Errors

Zoom Errors

Lamp Errors

Cyan Errors

Magenta Errors

Yellow Errors

CTO Errors

Clean Air Filters

Lamp is Too Hot

Overheated

Active Lamp Timer

Temp. Sensor Errors

**Fixture States** - Recorded following actions: Fixture On, Fixture Off, Lamp On, Lamp Off.

**Fixture Position** - Recorded installation positions of the fixture:

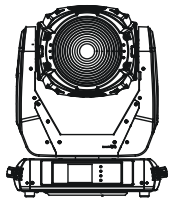

Disp-FN

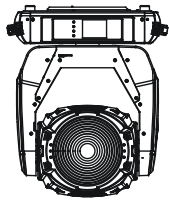

Disp-FI

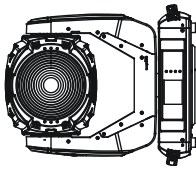

Disp-ST

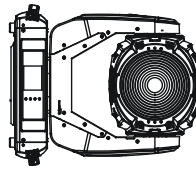

Disp-SB

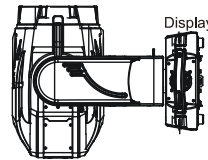

Disp-T

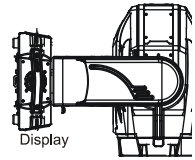

Disp-B

**Fixture Temperatures** - Recorded temperatures which have exceeded defined levels.

## 7.3 Tab "Personality"



**User mode** - The Robin 300 Plasma Wash allows you to recall up to 3 user settings. After switching the fixture on for the first time, the User A settings is active. Now all changes made in the "Personality" menu , "Addressing" menu and the "Music Trigger" and "Preset Playback" items from the "Stand-alone" menu are saved to the User A settings. If you now select the User B settings, from this moment the changes made in these menus will be saved to the User B settings. After switching the fixture off and on, the User B setting is active. In this way you may use the 3 fixture operating behaviours.

**User A Settings** - the function recalls the user A settings.

**User B Settings** - the function recalls the user B settings.

**User C Settings** - the function recalls the user C settings.

**DMX Preset** - Use the menu to select desired channel mode.

**Mode 1** - 19 control channels

**Mode 2** - 16 control channels

**Mode 3** - 14 control channels

**View Selected Preset** - Use the menu to display channels included in the selected mode.

**Pan/Tilt Settings** - Use the menu set behaviour of both pan and tilt movements.

**Pan Reverse** - The item allows to invert pan movement.

**Tilt Reverse** - The item allows to invert tilt movement.

**Pan/Tilt Feedback** - The item allows to return the mowing head to the required pan/tilt position after changing the position by an external force if this option is set on.

Note. Be careful, the Pan/Tilt Feedback should be permanent On, the option Off is not suitable for standard

operation and the head of the fixture can be damaged!

**Pan/Tilt mode** - Use this menu to set the mode of the pan/tilt movement

**Time mode** – The pan and tilt will move with different speeds and they will come at the same time to the end point of their tracks (pan and tilt use their optimal speeds). Time of the pan/tilt movement (25.5 sec. max.) is set by the channel "Pan/Tilt speed, Pan/Tilt time".

**Speed Mode** - Both Pan and tilt will move with the same speed as adjusted at the channel "Pan/Tilt speed, Pan/Tilt time".

**Microphone Sensitivity** - Enter the menu if you want to adjust the microphone sensitivity from 1 (max.) to 20 (min.).

**Blackout Settings** - Use the menu if you need to close the light output under certain conditions which are described below

**Blackout DMC** - Blackout during movement correction. Set this option On if you wish to close light output during the time when the head goes to its correct position, which has been changed by an external force.

**Active Blackouts** - Use this menu if you wish to close the light output during effect changes.

**Pan/Tilt Moving** - The menu item enables to close light output while the pan/tilt coordinates are changing.

**Colour Wheel Moving** - The menu item enables to close light output while the colour wheel is moving.

**Init Effect Positions** - Use the menu to set all effects to the desired positions at which they will stay after switching the fixture on without DMX signal connected.

**Screen Settings** - Use this menu to change the touch screen settings.

**Display Intensity** - The item allows to control the intensity of the screen (1-min., 10-max.).

**Screen saver Delay** - The item allows you to keep the screen on or to turn it off automatically after 1-10 minutes after last touch (or pressing any button on the control panel).

**Touchscreen Lock** - The item allows you to lock the screen after last touch (or pressing any button on the control panel). The time delay can be set in range of 1-10 minutes. To unlock the screen, press the [ENTER/Display On] button.

**Recalibrate Touchscreen** - The item starts calibration of the touchscreen. Follow the instructions on the screen.

**Display Orientation** - The menu allows to change display orientation.

**Normal** - Standard display orientation if the fixture is placed horizontally (e.g. on the ground).

**Inverted** - Inverted orientation (needed if the fixture is hanging on the truss).

**Auto** - The option activates a gravitation sensor for automatic screen orientation.

Note: **Auto** option is set as default. You change the display orientation by touching the icon  on the display, and the option set in the "Display Orientation" menu is temporarily overridden.

**Temperature unit** - Use the menu item to change temperature unit from °C to °F.

**Fan Mode** - Use the menu to set the fixture fans to max. power mode ("**High**") or to auto-control mode ("**Auto**").

**Date & Time Settings** - Use this menu to set current date and time for the fixture log system (menu "**View Logs**"). Set this menu item before first fixture operation.

**Default Settings** - The menu item allows to set all fixture parameters to the default (factory) values.

## 7.4 Tab "Manual Control"



**Reset Functions** - The menu allows to reset the fixture either per function modules or all modules together.

**Total Reset** - The item resets all function modules.

**Pan/Tilt Reset** - The item resets a pan and tilt movement.

**Colour System Reset** - The item resets a colour wheel and CMY/CTO flags.

**Strobe Reset** - The item resets strobe lamellas.

**Optics Reset** - The item resets a zoom module.

**Preset Effect Control** - Use the menu to show preset positions of each channel effect.

**Manual Effect control** - Use the menu to control all fixture channels by means of the control panel.

## 7.5 Tab "Stand-alone"



**Test Sequences** - Use the menu to run a test/demo sequences without an external controller, which will show you some possibilities of using Robin 300 Plasma Wash.

**Dynamic Mode** - This mode uses all Robin 300 Plasma Wash functions including pan/tilt movement and therefore is good for a complete introduction of the fixture.

**Static Mode** - This mode is suitable for projections on the wall, ceiling or ground without any pan/tilt movement. Adjust the pan, tilt and zoom to the desired positions and start test sequences by touching the green ► icon.

**Music Trigger** - Use the item to activate the sound control of the running program via the built-in microphone.

**Preset Playback** - This menu allows you to select the program which will be played in a loop after switching the fixture on (the option is commonly used in a stand-alone operation without an external controller).

**None** - The option disables "Presetting playback" function.

**Test** - The option starts the test sequences.

**Prog. 1** - The option starts user program No. 1.

**Prog. 2** - The option starts user program No. 2.

**Prog. 3** - The option starts user program No. 3.

**Play program** - Use the menu to run desired program in a loop.

**Play Program 1** - The option starts user program No.1.

**Play Program 2** - The option starts user program No. 2.

**Play Program 3** - The option starts user program No. 3.

**Edit Program** - Use the menu to create or to edit desired program. The Robin 300 Plasma Wash offers 3 free programs, each up to 100 steps.

**Edit Program 1** - The option allows to edit user program No.1.

**Edit Program 2** - The option allows to edit user program No.2.

**Edit Program 3** - The option allows to edit user program No.3

To edit program:

1. Touch the item which you want to edit ("Edit Program 1" - "Edit Program 3").
2. Touch the item "Edit Program Steps".
3. Touch the item "Step 1".
4. From the list of effects touch desired effect and set its value. Browse through the list by touching the [up arrow] and [down arrow] and set all desired effects.  
An item "Step Time" (value of 0-25.5 sec.) is the time during which effects last in the current step
5. Save adjusted effects to the current step by touching the [confirm] or save and copy them to the following step by touching the [confirm+copy]. By touching the text box "Preview" next to the current program step you can view created scene.
6. Repeat the steps 4 and 5 for next program steps.
7. After editing desired program steps, adjust the length of the program by touching the text boxes "Start Step" and "End Step".

Meaning of the icons used in the "Edit Program" menu:

↓ - moves down on the next page

↑ - moves up on the previous page

✓ - saves adjusted values and leaves menu

✓ - saves values to the current step and copy them to the following prog. step

✗ - leaves menu without saving values

There is a chart describing behaviour of items "Pan/Tilt Macro" and "P./T. Macro Speed".

<b>DMX</b>	<b>Pan/Tilt Macro</b>
0 - 9	Disabled pan/tilt macro
10 - 31	Reserved
32 - 63	Figure of circle (from small to large)
64 - 95	Figure of horizontal eight (from small to large)
96 - 127	Figure of vertical eight (from small to large)
128 - 159	Figure of rectangle (from small to large)
160 - 191	Figure of triangle (from small to large)
192 - 223	Figure of star (from small to large)
224 - 255	Figure of cross (from small to large)
	<b>Pan/Tilt Macro Speed</b>
0	No macro generation
1 - 127	Macro generation from fast to slow-forwards
128 - 129	No macro generation
130 - 255	Macro generation from slow to fast-backwards

## 7.6 Tab "Service"



**Adjust DMX Values** - The menu allows you to set all effects to desired positions before fine calibration of the effects .

**Adjust Lamp** - This item opens the light output of the fixture and enables to aim the light beam on the wall to perform the fine lamp adjustment.

**Calibrations** - This menu enables fine calibration of fixture effects and download default calibration values.

**Calibrate Effects** - The menu allows the fine adjustment of effects. The menu contains list of effects which can be calibrated:

**Pan**- a fine pan movement

**Tilt** - a fine tilt movement

**Colour Wheel** - a colour wheel

**Colour Wheel Fine** - a fine movement of the colour wheel

By using these items you can calibrate and adjust effects to their right positions.

### Calibration via the control board

1. Disconnect DMX controller from the fixture and enter the "Calibrate Effects" menu.
2. Use the [up arrow] and [down arrow] to find desired effect and touch it to enter the fine effect adjustment screen.
3. Set desired value and save it by touching the [confirm].
4. Repeat steps 2 and 3 for the next effects.
5. After calibrating all effects, touch the [confirm] to save all adjusted values and reset the fixture.

### Calibration via the DMX controller

1. Connect DMX controller to the fixture and set fixture effects to the desired positions before fine calibration.
2. Enter the "Calibrate Effects" menu and now you can exactly calibrate desired effects by DMX controller. There is a calibration protocol:

Effect	Mode 1	Mode 2	Mode 3
Pan	channel 20	channel 16	channel 14
Tilt	channel 21	channel 17	channel 15
Colour Wheel	channel 22	channel 18	channel 16
Colour Wheel Fine	channel 23	channel 19	channel 17

After having calibrated all effects, touch the [confirm] to save adjusted values and reset the fixture.

**Load Default Calibrations** - The item loads default (factory) calibration values.

**Updating software** - The menu item allows you to update software in the fixture via either serial or USB port of PC.

The following are required in order to update software:

- PC running Windows 95/98/2000/XP or Linux
- DMX Software Uploader
- Flash cable RS232/DMX No.13050624 (if you want to use a serial port of PC)
- Robe Universal Interface (if you want to use a USB port of PC)

Note 1: Software update should execute a qualified person. If you lack qualification, do not attempt the update yourself and ask for help your ROBE distributor.

Note 2: DMX address, IP address, programs 1-3 and all items in the menu "Personality" will be set to their default (factory) values.

### To update software in the fixture:

#### I. Installation of the DMX Software Uploader.

1. DMX Software Uploader program is available from the ROBE web site at WWW.robe.cz.
2. Make a new directory ( e.g. Robe\_Uploader) on your hard disk and download the software to it.
3. Unpack the program from the archive. If the Robe fixture is produced in both magnetic and electronic ballast version, name of DMX Software Uploader is the same for both versions.

#### II. Fixture software updating.

1. Determine which of your ports is available on your PC and connect it:
  - with the DMX input of the fixture if you using the flash cable RS232/DMX
  - with the DMX output of the Robe Universal Interface if you using the USB cable.Disconnect the fixture from the other fixtures in a DMX chain. Turn both the computer and the fixture on. Make sure the lamp is switched off (only if the fixture involves a lamp).
2. Switch the fixture to the updating mode by touching the "Updating Software " item  
Note: If you do not want to continue in software update, you have to switch off and on the fixture to escape from this menu.

We recommend to cancel all running programs before starting the Software Uploader.

3. Run the Software Uploader program. Select desired COM and then click on the Connect button. (Select COM if the serial port is used or Robe Universal Interface if the USB port is used). If the connection is OK, click on the "Start Uploading button" to start uploading. It will take several minutes to perform software update.

If the option "Incremental Update" is not checked, all processors will be updated (including processors with the same software version).

If you wish to update only later versions of processors, check the "Incremental Update box".

Avoid interrupting the process. Update status is being displayed in the Info Box window.

When the update is finished, the line with the text "The fixture is successfully updated" will appear in this window and the fixture will reset with the new software.

Note: In the case of an interruption of the upload process (e.g. power cut), the fixture keeps the updating mode and you have to repeat the software update again.

## 7.7 Icon "Lamp menu"



**Lamp Status** - The item enables to switch the lamp on/off. The MSD Gold 300/2 MiniFastFit lamp is a cold restrike type, that means, that it has to be cold before striking.

**Settings** - The menu offers many items for setting of lamp behaviour.

**Lamp Ignition Delay** - The item allows to set the time delay( 0-90sec.) before igniting the lamp by DMX command. If the lamp is started directly from the control panel, the time delay will be ignored.

**Lamp Light Sensor** - Select this item to switch the light sensor off. The option "On" is intended for a standard operation. The option "Off" is for "emergency operation" only! If the lamp light sensor is switched off, the fixture will still try to ignite the lamp (even when the lamp is damaged or absent), on this account some electronics parts of the fixture can be damaged!

**Lamp On/Off Settings** - Use the menu to set rules for automatic switching on/off the lamp.

**Lamp On Power On** - If the item is on, the lamp will be automatically turn on after switching the fixture on.

**Lamp Off via DMX** - The item enables to switch the lamp off via DMX command from DMX controller.

**Lamp On if DMX Present** - The item allows you to strike the lamp automatically after 26 seconds if DMX signal is present on the fixture's DMX input.

**Lamp Off if not DMX** - The item allows you to switch off the lamp automatically after 2 minutes



if DMX signal is missing on the fixture's DMX input.

**Green mode** - If this item is set on, the lamp power at shutter=0 DMX will be reduced to 20% of its nominal power. This setting can be temporarily overwritten by the DMX value at the channel "Power/Special functions" (ranges of 30-39 DMX and 40-49 DMX).

**Note:** because the plasma source comes up from 20% of its nominal power to the full power typically within 15seconds after opening blackout, some colour changes may be visible during this time period.

## 8. RDM

This fixture supports RDM operation. RDM (Remote Device Management) is a bi-directional communications protocol for use in DMX512 control systems, it is the new open standard for DMX512 device configuration and status monitoring.

The RDM protocol allows data packets to be inserted into a DMX512 data stream without adversely affecting existing non-RDM equipment. By using a special „Start Code,“ and by complying with the timing specifications for DMX512, the RDM protocol allows a console or dedicated RDM controller to send commands to and receive messages from specific moving lights.

RDM allows explicit commands to be sent to a device and responses to be received from it.

The list of commands for Robin 300 Plasma Wash is the following.

Parameter ID	Discovery command	SET command	GET command
DISC_UNIQUE_BRANCH	*		
DISC_MUTE	*		
DISC_UN_MUTE	*		
DEVICE_INFO			*
SUPPORTED_PARAMETERS			*
SOFTWARE_VERSION_LABEL			*
DMX_START_ADDRESS		*	*
IDENTIFY_DEVICE		*	*
DEVICE_MODEL_DESCRIPTION			*
MANUFACTURER_LABEL			*
DEVICE_LABEL		*	*
SENSOR_DEFINITION			*
SENSOR_VALUE			*
DISPLAY_INVERT		*	*
DISPLAY_LEVEL		*	*
PAN_INVERT		*	*
TILT_INVERT		*	*
DEVICE_RESET		*	
DMX_PERSONALITY		*	*
DMX_PERSONALITY_DESCRIPTION			*
STATUS_MESSAGES			*
STATUS_ID_DESCRIPTION			*
LAMP_STATE		*	*
LAMP_ON_MODE <sup>1</sup>		*	*
DEVICE_HOURS <sup>2</sup>			*
LAMP_HOURS <sup>2</sup>			*
LAMP_STRIKES <sup>2</sup>			*

<sup>1</sup>...Another options for this command (only for Robe's fixtures):

value PARAMETER\_DATA=0x84 - lamp OFF by DMX value on DMX channel

value PARAMETER\_DATA=0x88 - lamp OFF if DMX is not present

<sup>2</sup>...Commands relative resetable values

## 9. Error and information messages

Occurred errors during fixture operation are signalled by the yellow warning icon at the bottom line of the screen:

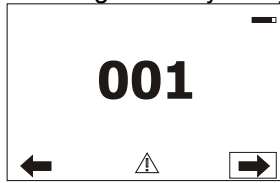

Touch the warning icon or press the [ESCAPE] button to display error messages.

List of error and information messages:

### ***Temper.Sensor Error***

The message informs you that the communication between the head temperature sensor and the main processor failed and the lamp has been switched off.

### ***Tilt Error 1 (Tilt Error 2)***

This message will appear after the reset of the fixture if the head's magnetic-indexing circuit malfunctions (sensor failed or magnet is missing) or the stepping motor is defective or its driving IC on the PCB. The head is not located in the default position after the reset.

### ***Pan Error 1 (Pan Error 2)***

This message will appear after the reset of the fixture if the yoke's magnetic-indexing circuit malfunctions (sensor failed or magnet is missing) or the stepping motor is defective or its driving IC on the PCB. The yoke is not located in the default position after the reset of the fixture.

### ***Colour Wheel Error 1 (Colour Wheel Error 2)***

The messages will appear after the reset of the colour wheel if this wheel is not located in the default position.

### ***Cyan Lamella Error 1 (Cyan Error 2)***

The messages will appear after the reset of the cyan flag if the flag is not located in the default position.

### ***Magenta Lamella Error 1 (Magenta Error 2)***

The messages will appear after the reset of the magenta flags if the flag is not located in the default position.

### ***Yellow Lamella Error 1 (Yellow Error 2)***

The messages will appear after the reset of the yellow flags if the flag is not located in the default position.

### ***CTO Lamella Error 1 (CTO Lamella Error 2)***

The messages will appear after the reset of the CTO flag if the flag is not located in the default position.

### ***Strobe 1 Error 1 (Strobe 1 Error 2)***

The messages will appear after the reset of the dimmer/strobe module if the strobe lamella 1 is not located in the default position.

### ***Strobe 2 Error 1 (Strobe 2 Error 2)***

The messages will appear after the reset of the dimmer/strobe module if the strobe lamella 2 is not located in the default position.

### ***Zoom Error 1 (Zoom Error 2)***

The messages will appear after the reset of the zoom module if the zoom lamellas are not located in the default positions.

### ***Clean Air Filters***

The message informs that the item "Elapsed Time" in the "Fixture Information" menu is at 0 value. Clean air filters and reset this counter.

*Messages concerning the lamp and lamp driver:*

### ***Lamp Starting***

The message informs you that the lamp status is on but the lamp does not light.

**Overtemp**

The message informs you that the fixture had been overheated and the lamp was shut down due to excessive temperature.

**Start Failure**

The message informs you that the lamp failed to start within 30 secs.

**Run Failure**

The message informs you that the lamp was shut down while running.

**Too Warm**

The message informs you that the lamp is too warm.

**General Failure**

The message informs you that the internal failure was sensed as temp. sensor failure.

**28V Failure**

The message informs you that the lamp was shut down due to undervoltage.

**28V Low**

The message informs you that the DC voltage falls below undervoltage limit.

## 10. Technical Specifications

**Electrical:**

Power supply:.....electronic auto-ranging  
Input voltage range:..... supply 100-240V, 50/60Hz  
Live Fuse:.....T 6.3 A  
Neutral Fuse:.....T 6.3 A  
Power consumption:.....400 VA

**Light source:**

LIFI ENT 31-02, CCI=5300K, CRI=94, rated average life:10 000 hours.

**Optical System:**

Metal reflector  
zoom range: 10°-35°

**Colour wheel:**

7 replaceable 'SLOT&LOCK' dichroic filters (including UV filter)

**CMY + CTO mixing module**

Smooth CMY colour mixing system  
Colour temperature correction filter lowers colour temperature from 6000K to 3200 K  
30 colour macros

**Zoom**

Motorized zoom: 10°-35°

**Strobe:**

Strobe effect with variable speed (max.15 flashes/sec.)

**Dimmer:**

Smooth dimmer from 0 - 100 %

**Electronics:**

- Graphic touch screen for fixture setting and addressing
- Gravitation sensor for auto screen positioning
- Battery backup of the touch screen
- Readout fixture and lamp usage, receiving DMX values, temperatures, etc
- Built-in analyzer for easy fault finding, error messages
- Remotely switching on/off the lamp
- Built-in demo sequences
- Black-out while head moving or colour changing
- Silent fans cooling,
- Self-resetable thermo-fuse
- Stand-alone operation
- 3 user editable programs, each up to 100 steps
- Supported protocols: USITT DMX 512, RDM, ArtNet, MANet, MANet2
- Support of RDM (Remote Device Management)
- 3 DMX modes (14, 16, 19 control channels)

**Pan/Tilt**

- Pan movement range 540°
- Tilt movement range 260°
- 16 bit movement resolution
- Automatic Pan/Tilt position correction
- Remotely controllable speed of pan/tilt movement for easy programming
- Movement control: tracking and vector
- Pan/tilt-lock mechanism

**Rigging**

- Mounting points: 2 pairs of 1/4-turn locks
- Mounting horizontally or vertically via 2 Omega brackets

**Temperatures**

- Maximum ambient temperature : 45° C
- Maximum housing temperature : 80° C

**Minimum distances**

- Min. distance from flammable surfaces: 1 m
- Min. distance to lighted object: 2 m

**Total heat dissipation**

1262 BTU/h (calculated)

**Weight (net):**

20.5 kg

**Dimensions (mm)**

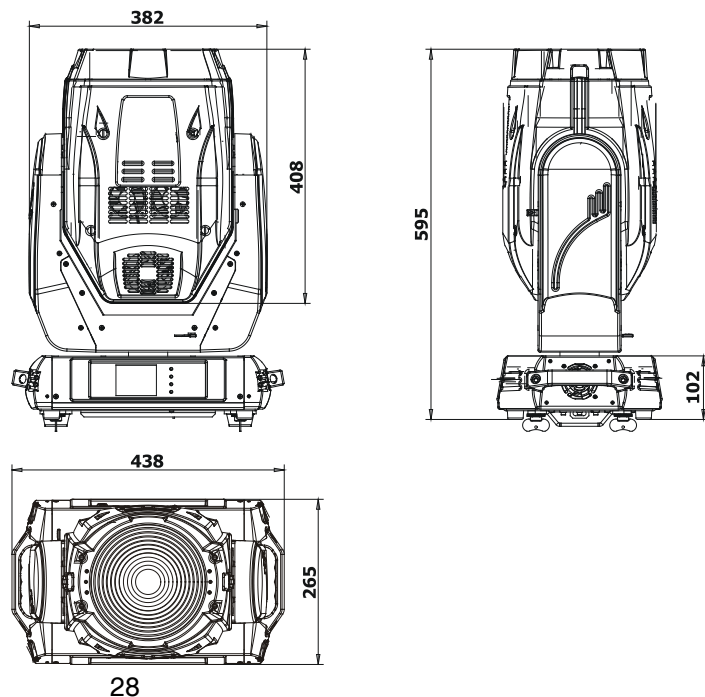

## Accessories

- Omega holder (No.99010420).....2 pcs

## Optional Accessories

- Flash cable RS232/DMX (No.13050624)
- Module of Front wide-angle lens D200 (No.99010879)
- Top hat standard 45 (No.10980044)
- Top hat long 70 (No.10980045)
- Top hat 3-ring 45 (No.10980046)
- Top hat 3-ring 70 (No.10980050)

## 11. Maintenance and cleaning

It is absolutely essential that the fixture is kept clean and that dust, dirt and smoke-fluid residues must not build up on or within the fixture. Otherwise, the fixture's light-output will be significantly reduced. Regular cleaning will not only ensure the maximum light-output, but will also allow the fixture to function reliably throughout its life. A soft lint-free cloth moistened with any good glass cleaning fluid is recommended, under no circumstances should alcohol or solvents be used!

***DANGER !***  
***Disconnect from the mains before starting any  
maintenance work***

The front fresnel lens will require weekly cleaning as smoke-fluid tends to building up residues, reducing the light-output very quickly. The cooling-fans should be cleaned monthly.

The interior of the fixture should be cleaned at least annually using a vacuum-cleaner or an air-jet.

Dichroic colour filters, CMY lamellas and the internal zoom lamellas should be cleaned monthly.

Remove dust and dirt from the fans and cooling vents using a soft brush and vacuum-cleaner.

**Important! Check the air filters periodically and clean before they become  
clogged!**

Clean the air filters placed in the fixture's covers. Use a vacuum cleaner, compressed air or you can wash them and put back dry.

After replacing the air filters, reset the elapsed time counter in the menu "Information" (Information--->Air Filters--->Elapsed Time).

DMX protocol

Robin 300 Plasma Wash - DMX protocol, version 1.1						
Mode/channel			DMX Value	Function	Type of control	
1	2	3				
1	1	1		<b>Pan</b>		
			0 - 255	Pan movement by 540°	proportional	
2	2	*		<b>Pan Fine</b>		
			0 - 255	Fine control of pan movement	proportional	
3	3	2		<b>Tilt</b>		
			0 - 255	Tilt movement by 260°	proportional	
4	4	*		<b>Tilt fine</b>		
			0 - 255	Fine control of tilt movement	proportional	
5	5	3		<b>Pan/Tilt speed , Pan/Tilt time</b>		
			0	Max. speed (tracking mode)	step	
				<b><i>P./T. speed-set Speed Mode in menu: Pan/Tilt Mode</i></b>		
			1 - 255	Speed from max. to min. (vector mode)	proportional	
				<b><i>P./T. time - set Time Mode in menu: Pan/Tilt Mode</i></b>		
			1 - 255	Time from 0.1 s to 25.5 sec.	proportional	
6	6	4		<b>Power/Special functions</b>		
			0 -29	Reserved	step	
				<i>To activate following junctions, stop in DMX value for at least 3 s and shutter must be closed at least 3 sec. („Shutter/Strobe“ channel 17/15/13 must be at range: 0-31 DMX). Corresponding menu items are temporarily overridden).</i>		
			30-39	Lamp power reduced if "Shutter/strobe" channel=0 DMX	step	
			40-49	Full Lamp power if "Shutter/strobe" channel=0 DMX	step	
			50 - 59	Pan/Tilt speed mode	step	
			60 - 69	Pan/Tilt time mode	step	
			70 - 79	Blackout while pan/tilt moving	step	
			80 - 89	Disabled blackout while pan/tilt moving	step	
			90 - 99	Blackout while colour wheel moving	step	
			100 - 109	Disabled blackout while colour wheel moving	step	
			110 - 129	Reserved		
				<i>To activate following functions, stop in DMX value for at least 3 seconds.</i>		
			130 - 139	Lamp On,reset(total reset except pan/tilt reset)	step	
			140 - 149	Pan/Tilt reset	step	
			150 - 159	Colour system reset	step	
			160 - 169	Reserved		
			170 - 179	Dimmer/Shutter reset	step	
			180 - 189	Zoom reset	step	
			190 - 199	Reserved	step	
			200 - 209	Total reset	step	
			210 - 229	Reserved		
			230 - 239	Lamp Off	step	
			240 - 255	Reserved		
7	7	5		<b>Colour wheel</b>		
				<b><i>Continual positioning</i></b>		
			0	Open/white	proportional	
			16	Deep red	proportional	
			32	Deep blue	proportional	
			48	Orange	proportional	
			64	Green	proportional	

## DMX protocol

Mode/channel			DMX Value	Function	Type of control
1	2	3			
			80	Light red	proportional
			96	Amber	proportional
			112	UV filter	proportional
			128-129	White	step
				<b>Positioning</b>	
			130-137	Deep red	step
			138-145	Deep blue	step
			146-153	Orange	step
			154-163	Green	step
			164-171	Light red	step
			172-181	Amber	step
			182-189	UV filter	step
			190 - 215	Forwards rainbow effect from fast to slow	proportional
			216 - 217	No rotation	step
			218 - 243	Backwards rainbow effect from slow to fast	proportional
			244 - 249	Random colour selection by audio control	step
				(Set microphone sensitivity in menu „Personality“)	
			250 - 255	Auto random colour selection from fast to slow	proportional
<b>8</b>	<b>*</b>	<b>*</b>		<b>Colour wheel - fine positioning</b>	
			0 - 255	Fine positioning	proportional
<b>9</b>	<b>8</b>	<b>6</b>		<b>Cyan</b>	
			0 - 255	Cyan (0-white, 255-full cyan)	proportional
<b>10</b>	<b>9</b>	<b>7</b>		<b>Magenta</b>	
			0 - 255	Magenta (0-white, 255-full magenta)	proportional
<b>11</b>	<b>10</b>	<b>8</b>		<b>Yellow</b>	
			0 - 255	Yellow (0-white, 255-full yellow)	proportional
<b>12</b>	<b>11</b>	<b>9</b>		<b>CTO filter</b>	
			0 - 255	(0-6000K, 255-3200K)	proportional
<b>13</b>	<b>12</b>	<b>10</b>		<b>CMY colour macros</b>	
			0 - 7	No function	step
			8 - 15	Macro 1	step
			16 -23	Macro 2	step
			24-31	Macro 3	step
			32-39	Macro 4	step
			40-47	Macro 5	step
			48-55	Macro 6	step
			56-63	Macro 7	step
			64-71	Macro 8	step
			72-79	Macro 9	step
			80-87	Macro 10	step
			88-95	Macro 11	step
			96-103	Macro 12	step
			104-111	Macro 13	step
			112-119	Macro 14	step
			120-127	Macro 15	step
			128-135	Macro 16	step
			136-143	Macro 17	step
			144-151	Macro 18	step
			152-159	Macro 19	step
			160-167	Macro 20	step

DMX protocol

Mode/channel			DMX Value	Function	Type of control
1	2	3			
			168-175	Macro 21	step
			176-183	Macro 22	step
			184-191	Macro 23	step
			192-199	Macro 24	step
			200 - 207	Macro 25	step
			208 - 215	Macro 26	step
			216 - 223	Macro 27	step
			224 - 231	Macro 28	step
			232 - 239	Macro 29	step
			240 - 243	Macro 30	proportional
			244 - 249	Random macro selection by audio control	step
				(Set microphone sensitivity in menu "PErsonality")	
			250 - 255	Auto random macro selection from fast to slow	proportional
<b>14</b>	<b>13</b>	<b>11</b>		<b>CMY &amp; CTO Speed</b>	
			0 - 255	Speed of flags movement from max. to min.	proportional
<b>15</b>	<b>14</b>	<b>12</b>		<b>Zoom</b>	
			0 - 255	Zoom from min. to max. beam angle	proportional
<b>16</b>	*	*		<b>Zoom - fine</b>	
			0-255	Fine zooming	proportional
<b>17</b>	<b>15</b>	<b>13</b>		<b>Shutter/ strobe</b>	
			0	Shutter closed (lamp power reduced to 20% of nomin. power)*	step
			1-31	Shutter closed (full lamp power)	step
			32 - 63	Shutter open, Full lamp power	step
			64 - 95	Strobe-effect from slow to fast	proportional
			96 - 127	Shutter open (full lamp power)	step
			128 - 143	Opening pulse in sequences from slow to fast	proportional
			144 - 159	Closing pulse in sequences from fast to slow	proportional
			160 - 191	Shutter open (full lamp power)	proportional
			192 - 223	Random strobe-effect from slow to fast	proportional
			224 - 255	Shutter open (full lamp power)	step
<b>18</b>	<b>16</b>	<b>14</b>		<b>Dimmer intensity</b>	
			0 - 255	Dimmer intensity from 0% to 100%	proportional
<b>19</b>	*	*		<b>Dimmer intensity - fine</b>	
			0 - 255	Fine dimming	proportional
<p>* To reduce the lamp power set the value of 30-39 DMX at the channel "Power/Special functions"                      for temporary setting of the lamp power reduction or use the icon "Lamp menu"                      for permanent setting of the lamp power reduction</p>					