

MOVING HEAD

MH-575 S



User manual

stairville

CAUTION!

Risk of electric shock
Read instructions before installing
or connecting to power

Contents

Description of the unit	1
Inspection	2
Safety instructions	3
Lamp Installation	4
Rigging	5
Connection with the mains	6
Linking	6
Instruction for gobo replacement	7
DMX Channel Chart	8
DMX channel arrangement	12
Control Board	13
Maintenance	14
Replacing the Fuse	15
Appendix A	15
Product Specifications	16

Thank you for purchasing a MECH series projector. We are sure that it will serve you well provided you read and follow the advice contained in this instruction manual.

For your own safety please read this manual carefully, before applying power to, and using, the projector.

The manufacturer will not accept any liability for any resulting damages caused by the non-observance of this manual, or any unauthorised modifications to this projector.

Description of the unit

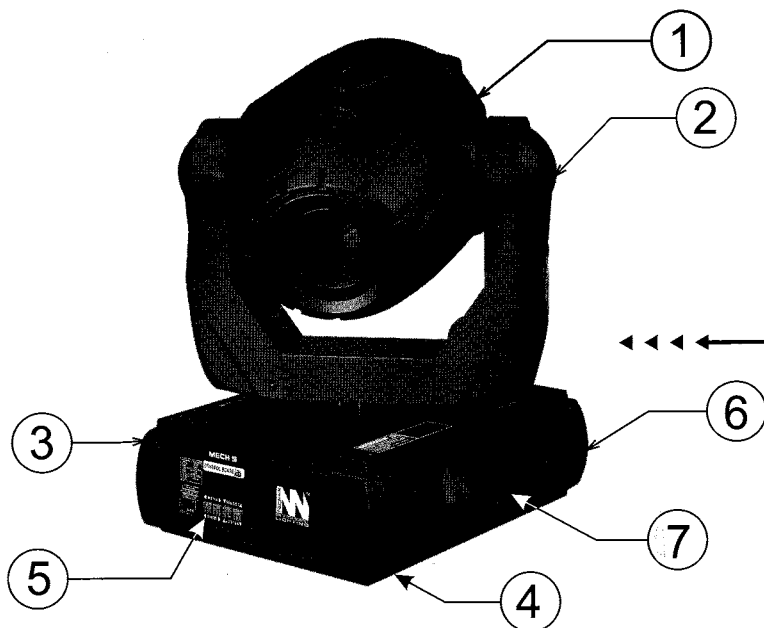

- 1. Projector-head
- 2. Yoke
- 3. Left side panel
- 4. Base
- 5. Control Board
- 6. Right side panel
- 7. Carrying handles

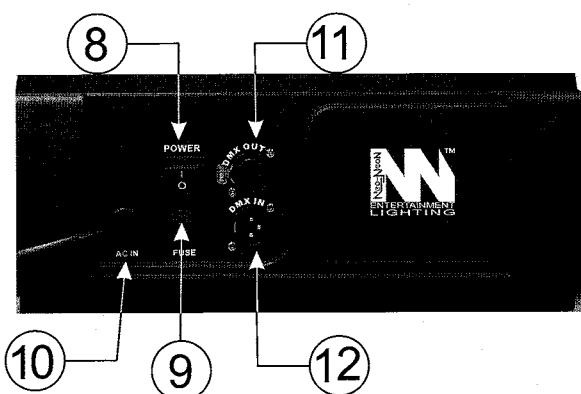

- Left side panel:*
- 8. Power-switch
 - 9. Fuse-holder
 - 10. Power Cord
 - 11. DMX-output
 - 12. DMX-input

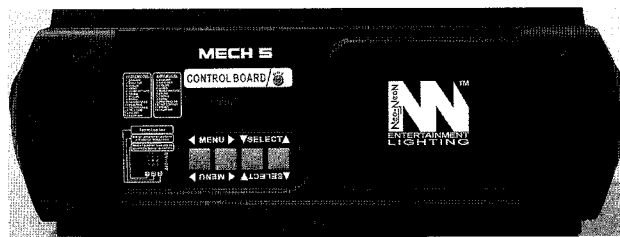

- Right side panel:*

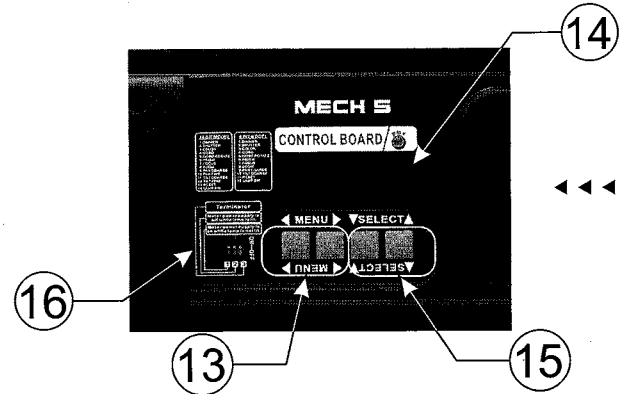

- Control Board:*
- 13. MENU (Function buttons)
 - 14. Display
 - 15. SELECT (ON/OFF or address number)
 - 16. DIP Switch

Inspection

Carefully unpack the carton, and make sure there has been no damage or loss caused by transportation.

Contact your Neo-Neon dealer by telephone or fax immediately if damage has occurred or if something is missing.

Packing List:

- A. MECH-5 Moving Head
- B. Operating Manual
- C. Bracket
- D. Gobo's
- E. Lamp (Optional)

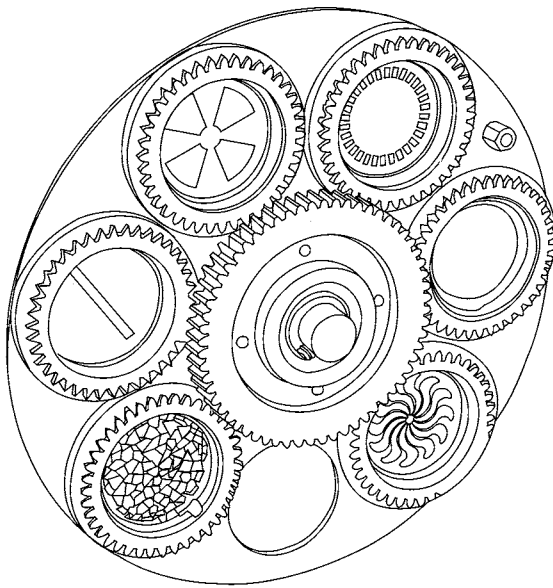

Safety instructions

- This appliance must be earthed (grounded).
- Disconnect power before removing covers or servicing.
- The covers must be closed while operating.
- MECH-5 contains no user serviceable parts. Refer servicing to qualified technicians only.
- Lamp and components become hot during operation. Allow time them to cool before handling.
- Keep flammable material at least one meter away from unit.
- Do not operate in wet conditions or near liquids.
- Keep air vents clear to avoid overheating.
- The lamp produces hazardous UV light. Do not look directly at the lamp when lit.
- Replace any blown or damaged fuses only with those of identical values.
- Before connecting to mains power, ensure the supply voltage matches that stated on the left side panel.

Lamp Installation

Warning!

When replacing the lamp, please wait 15 minutes after powering down to allow the unit to cool down! Always disconnect from main power prior to lamp replacement.

Do not touch the envelope (glass area) of the bulb with bare hands. If this happens, clean the lamp with alcohol and wipe it with a lint free cloth before installation.

1. Keep projector-head upward. Unscrew thumbscrews (S1) to detach the top cover.

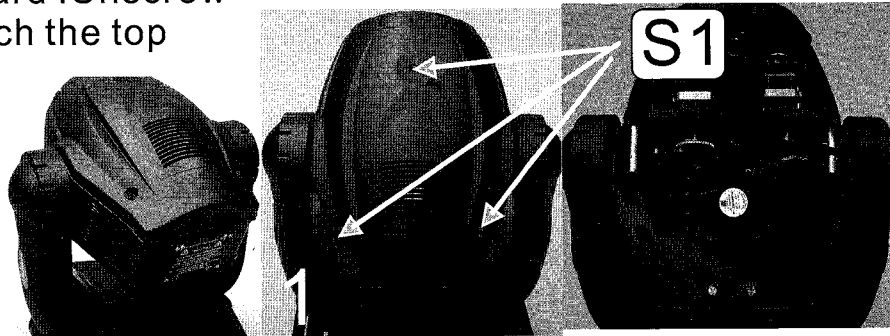

2. Unscrew screws (S2) to remove lamp cover and expose lamp compartment.

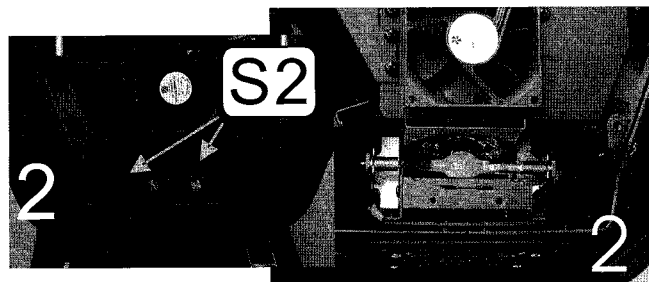

3. If installing a new lamp, loosen both screws on the double ended lamp to allow for the lamp to slide into the lamp socket slots. Lower lamp evenly.

4. If replacing a lamp, loosen both lamp screws (S3) to relieve tension from lamp socket slots so you can slide the lamp freely, upwards and out of the lamp socket. Lift the lamp evenly to remove.

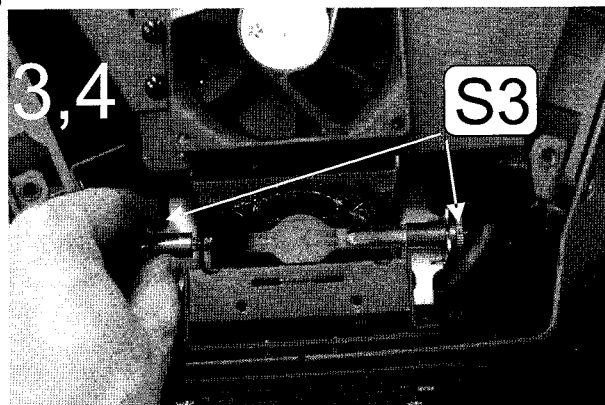

5. Before you tighten the lamp end screws, rotate the bulb until the nipple on the envelope (N) of the bulb is facing upwards as illustrated.

6. If you are replacing the lamp, you may want to log the fixture hours in order to track the lamps use. Once the lamp fitting is complete and the projector properly closed you may power up the projector and navigate to the (LPti) on the menu display to obtain this information.

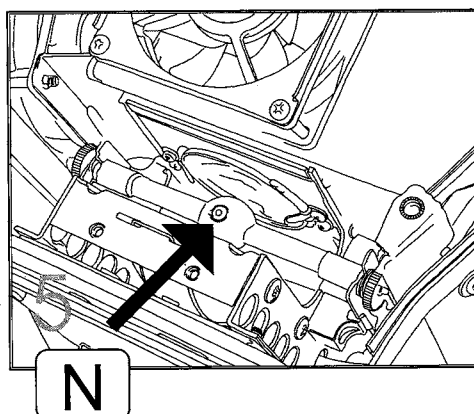

7. Note: this projector should be used with approved lamps only. The performance of this projector can not be guaranteed if other lamps are used.

Rigging:

The Mech-5 can be set on a flat stage floor directly or use clamps to mount on any kind of truss. Ensure the truss can take the weight of the projector.

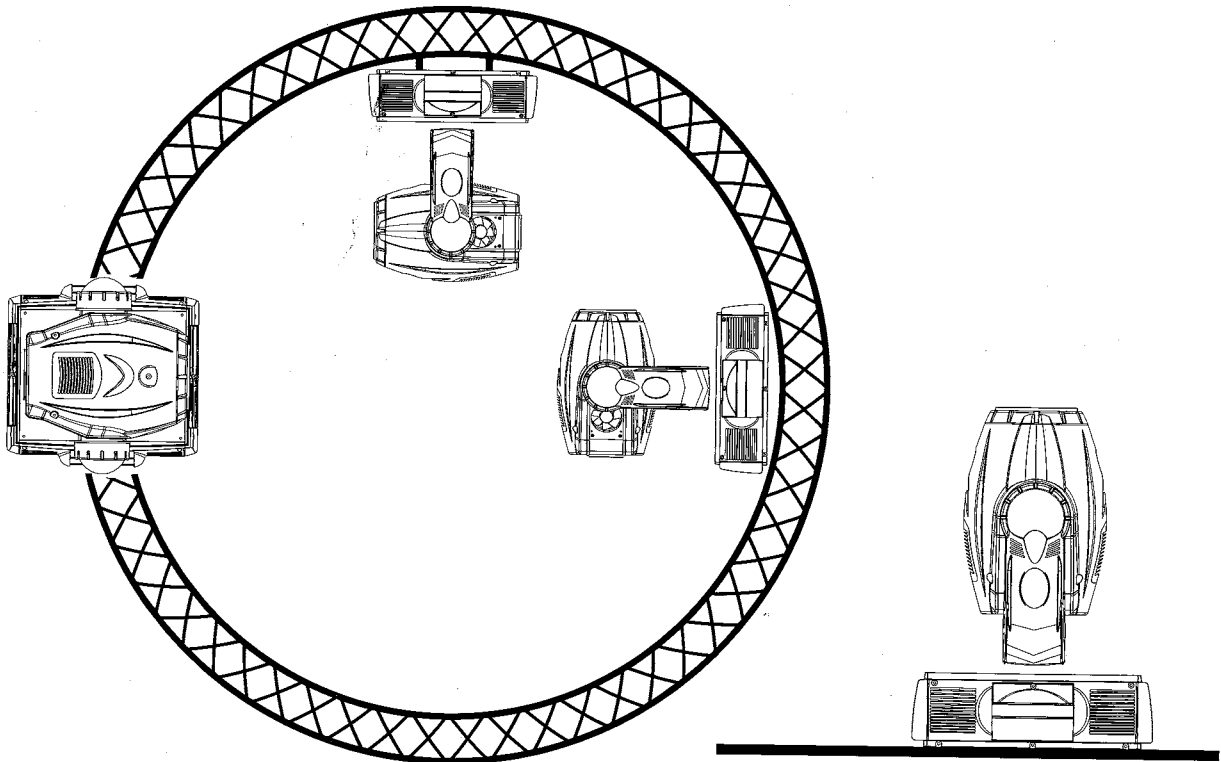

Use appropriate clamps for truss mounting. Attach the truss clamps (b) to the mounting brackets (a) and fix the mounting brackets to the underside of the projector base securely. A secondary safety must be used. This is a steel rope cable that is strong enough to carry 10 times the weight of the projector. The safety cable must be passed through the two holes (c) in the base of the projector and passed through the truss. Join the safety cable with the screw on carabines (clips) (d).

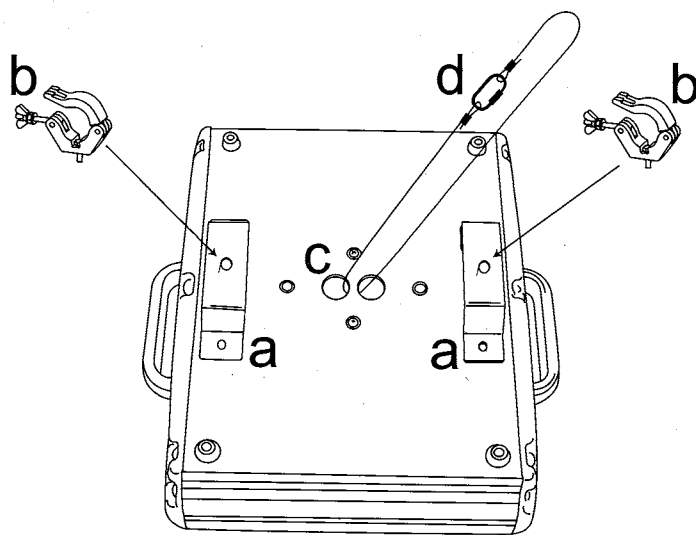

Connection with the mains

Connect the device to the mains with the correct power-plug. The connection of the cables is as follows:

Cable	Pin	International
Brown	Live	L
Blue	Neutral	N
Yellow/Green	Earth	

The earth/ground must be connected! The Mech-5 must not be connected to dimming-packs.

Control cable

Use 3-pin XLR data cables to link the controller to the projectors.

3-pin XLR connectors are follows:

DMX-output
XLR mounting-socket:

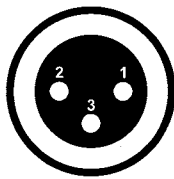

1:Ground
2:Signal(-)
3:Signal(+)

DMX-input
XLR mounting-plug:

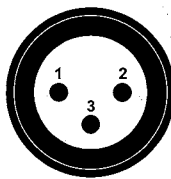

1:Ground
2:Signal(-)
3:Signal(+)

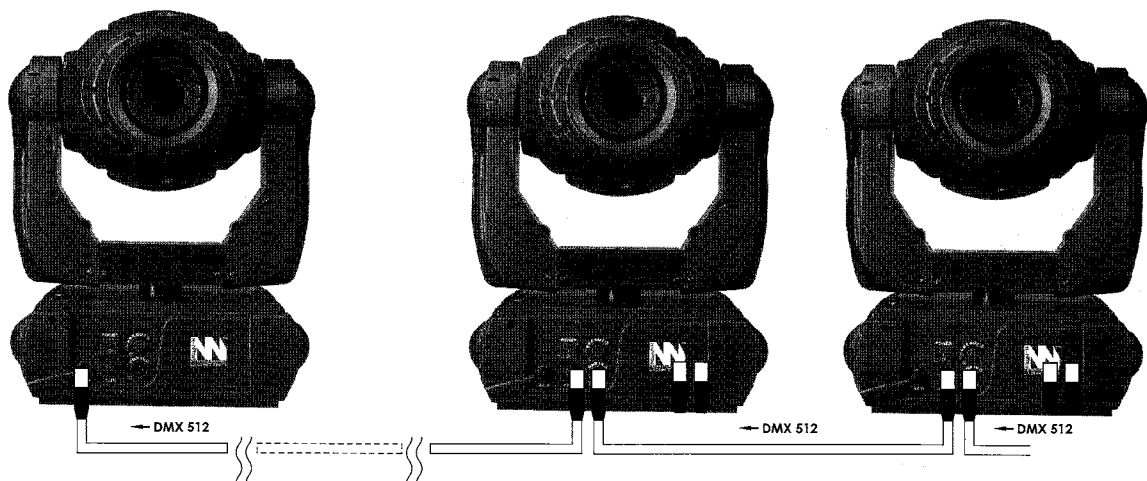

Connect the DMX output from the controller to the DMX input socket on the first projector. Connect the DMX output of the first projector to the DMX input of the second projector. Continue connecting the DMX output of each projector to the DMX input of the next until you have connected the last projector in the chain.

On the last projector in the chain set the DIP Switch #3 to the ON position, this will terminate the DMX chain.

Instructions for gobo replacement



DANGER!
Install the gobos with the device switched off. Unplug from mains before opening!

Please use only gobos that fit this projector-see appendix A for sizes.

Rotating GOBO wheel

1. Open the top cover (*Refer to the steps of lamp installation.), and loosen the screws with an appropriate tool then extract A. (See the figures below.)

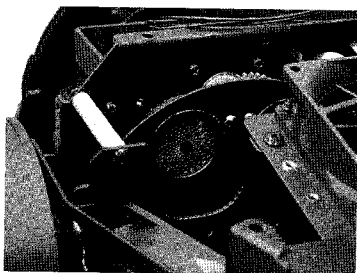
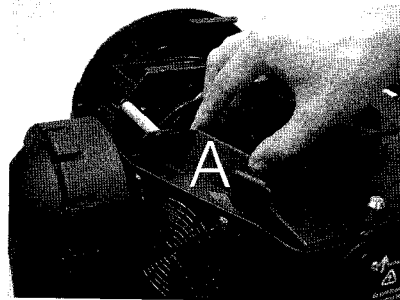
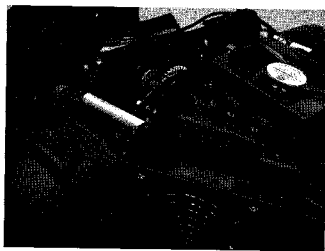

2. Turn the open (circle) of the GOBO wheel to the "U" shaped gap in order to extract the rotating GOBO easily.

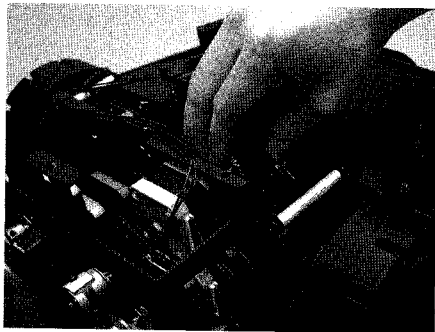

3. Using your fingers gently push out the gobo and spring retaining ring. Take care not to let either component fall inside.

4. Insert the new GOBO and the spring retaining ring (*Press the spring retaining ring tight with the appropriate tool in order to Ensure the GOBO is held securely.)

DMX Channel Values

16 Bit Movement

CHANNEL	VALUE	FUNCTION
1	000 <> 255	Dimmer Closed > Open (0-100%)
2	000 <> 001 002 <> 007 008 <> 063 064 <> 071 072 <> 127 128 <> 135 136 <> 191 192 <> 199 200 <> 253 254 <> 255	Shutter/Strobe Blackout Open Strobe: Slow > Fast (max 7fps) Open Pulse Strobe: Dark > Bright & Slow > Fast Open Pulse Strobe: Bright > Dark & Slow > Fast Open Random Strobe: Slow > Fast Open
3	000 <> 013 014 <> 027 028 <> 041 042 <> 055 056 <> 069 070 <> 083 084 <> 097 098 <> 111 112 <> 125 126 <> 139 140 <> 153 154 <> 167 168 <> 255	Color Wheel White (Open) Steel Blue Orange Green Blue Bright Blue Bright Pink Red Deep Blue Yellow Dark Pink Moss Green Light Blue Rainbow effect: Slow > Fast
4	000 <> 023 024 <> 047 048 <> 071 072 <> 095 096 <> 119 120 <> 143 144 <> 167 168 <> 255	Rotating Gobo Open Gobo 1 Gobo 2 Gobo 3 Gobo 4 Gobo 5 Gobo 6 Gobo Spin: Slow > Fast
5	000 <> 127 128 <> 191 192 <> 255	Gobo Rotation & Indexing Gobo Index (0° ~ 360°) Clockwise gobo rotation: Slow > Fast Counter clockwise gobo rotation: Fast > Slow
6	000 <> 001 002 <> 255	Prism Open Prism (static)
7	000 <> 255	Focus Near > Far
8	000 <> 127 128 <> 255	Zoom 18° 14°
9	000 <> 255	Pan Right (0°) > Left (570°) (128 = half way point)
10	000 <> 255	Tilt Down (0°) > Up (270°) (128 = half way point)
11	000 <> 255	Pan (Fine)
12	000 <> 255	Tilt (Fine)
13	000 <> 007 008 <> 063 064 <> 127 128 <> 255	Control Pan/Tilt Tracking Mode Pan/Tilt Vector Mode: Slow > Fast Mechanical Mechanical reset after 3 seconds
14	000 <> 047 048 <> 095 096 <> 159 160 <> 207 208 <> 255	Lamp ON/OFF Standby Hold 3 seconds for Lamp ON Standby Hold 3 seconds for Lamp OFF Standby

DMX Channels arrangement

Selected function	CHn1 OFF	CHn1 OFF	CHn1 ON	CHn1 ON
	16bit OFF	16bit ON	16bit OFF	16bit ON
CH 1	Dimmer	Dimmer	Pan coarse	Pan coarse
CH 2	shutter	shutter	Tilt coarse	Tilt coarse
CH 3	Color	Color	Dimmer	Pan fine
CH 4	Gobo	Gobo	shutter	Tilt fine
CH 5	Gobo rotate	Gobo rotate	Color	Dimmer
CH 6	Prism with rotate	Prism with rotate	Gobo	shutter
CH 7	Focus	Focus	Gobo rotate	Color
CH 8	Zoom	Zoom	Prism with rotate	Gobo
CH 9	Pan coarse	Pan coarse	Focus	Gobo rotate
CH 10	Tilt coarse	Tilt coarse	Zoom	Prism with rotate
CH 11	Control	Pan fine	Control	Focus
CH 12	Lamp SW	Tilt fine	Lamp SW	Zoom
CH 13		Control		Control
CH 14		Lamp SW		Lamp SW

Control Board

<i>Addr</i>	Press ▲ to increase DMX Address; ▼ to decrease. Press ▲▼ simultaneously to zero DMX address.
<i>L.P.t.</i>	Lamp used timer Press ▲▼ simultaneously for 3 seconds to zero lamp time. Unit : hour
<i>Shut</i>	Off : Normal On: Shutter closes during changing color gobo or prism. Shutter opens after color gobo and prism are properly positioned.
<i>Colo</i>	Off: Color wheel linear movement On: Color wheel fixed step advance
<i>Focu</i>	Off: Normal On: Focus adjustment
<i>r.PAn</i>	Off: Adjust X-axis from 0° to 570°. On: Adjust X-axis from 570° to 0°.
<i>r.tilt</i>	Off: Adjust Y-axis from 0° to 270°. On: Adjust Y-axis from 270° to 0°.
<i>l.b.br</i>	Off: 8bit control model On: 16bit control model
<i>dENo</i>	Off: Normal On: Self-demonstration
<i>SoFt</i>	Off: Quick paced function demonstration. On: Slow paced function demonstration.
<i>dPSE</i>	Off: Display off ; On: Display on While 'Off', press any key to turn on the display
<i>rSEt</i>	Off: Normal On: Self-zero all motors once
<i>dFSE</i>	Off: Normal On: Reset the unit as ex-works. Default returns to "OFF" position.
<i>LAMP</i>	Off: Lamp off Con : Lamp off & on via DMX control On: Lamp on
<i>turn</i>	Off: Display normal On: Display inverted
<i>CHnL</i>	Off: Assign Pan & Tilt's DMX address to channel 9-12 On: Assign Pan & Tilt's DMX address to channel 1-4
<i>F.t.</i>	Fixture used timer, Press ▲▼ simultaneously for 3 seconds to zero the timer. Unit : hour

- ⊙ Press ◀▶ simultaneously returning to "Addr".
- ⊙ Press ◀▶ simultaneously in advance before switching on the unit, release ◀▶ to erase all recorded data after switching On the unit as ex-works.
- ⊙ Once operation stopped, the unit stores all data. When restarting the unit, it starts with the latest Settings/options selected before the projector was switched off.

Maintenance

Refer maintenance to qualified technicians. Please disconnect power and signal wires before maintaining fixtures.

In order to preserve the MECH-5 in good condition, routine maintenance is essential. Follow the schedule below.

The Steps are as follows:

- The dichroic colour-filters, the metal gobo-wheel, the internal lenses and cooling fans should be cleaned with a soft brush monthly.
- The interior of the fixture should be cleaned at least half-yearly using a vacuum-cleaner or an air-jet.
Caution: Be careful not to damage the mechanisms or circuits when using the air-jet.
- To ensure a proper function and smooth rotation of the gobo-wheel, we recommend lubrication in six-month intervals.
Caution: Avoid damage to internal components turning the wheel, do not use excess lubrication.

When used in an environment where fog machines are used, the lenses, gobos and colour filters can become coated with residue from the fog . This can reduce the light output from the projector and also the image quality. Ensure the lenses, gobos and colour filters are cleaned regularly with a moist cloth (with a trace of detergent if necessary), we recommend cleaning every two weeks. DO NOT use any form of alcohol or solvent to clean these components.

Replacing the Fuse

If the fixture does not function, it may be that the fuse needs replacing. Use only a fuse of same type and specification.

Remove the electric power and flip the switch to the " off " position before replacing the fuse.

Replace the fuse as follows:

Step 1: Unscrew the screw of the fuse holder on the housing counterclockwise with an appropriate tool.

Step 2: Remove the broken fuse and then replace the new fuse.

Step 3: Reinsert and tighten the screw on the fuse-holder.

Step 4: Turn the power on for test.

Please contact your dealer if the fixture still does not work or if the new fuse blows.

Appendix A

GOBO Size

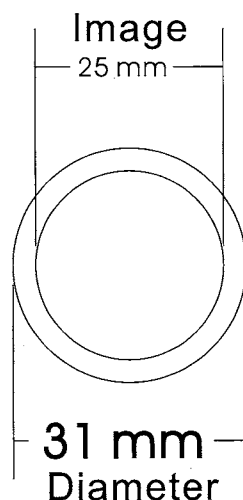

Product Specifications

Physical

Dimension(LxWxH): 412x335x580mm

Weight: 29.5 kg

AC supply

AC input: Certified power cord with or without plug

Voltage: 230, 240V 50/60Hz:

Fuse: AC 230V: 7A/250V

Power Consumption: 800W

Control and programming

Signal pinout: pin 1 shield, pin 2 (-), pin 3 (+)

Setting and addressing: LED control panel

Protocol: USITT DMX-512

Pan/tilt resolution: 8 or 16 bit

DMX channels: 12-14

Signal input: 3-pin XLR male

Signal output: 3-pin XLR female

Source

Lamp: 575W discharge

Base: SFC10-4

Approved models: Philips MSI-575/HR (1000 hr; 6000K)

Philips MSI-575/2 (1000 hr; 6500K)

Note : Use only approved lamps in this unit.

Control: Automatic and DMX remote lamp on/off.

Electromechanical effects

Color wheel 1: 11 dichroic colors+white

Rotating gobo wheel: 6 replaceable gobos+white

Gobo rotation: adjustable speed and position direction

Dimmer: 0-100% linear dimmer

Strobe: 1-7Hz fast flashing

Fixed 3-facet prism: in/out variable speed and direction

Focus: 2m-infinity

Iris: Mini 4°-Max 15°

Pan: 0°~570°

Tilt: 0°~270°

Motor control: auto-electronic reset

Gobos

Metal gobo: Diameter:31 mm

Maximum image diameter:25 mm

Metal type:white iron

Glass gobo: Diameter:31 mm

Maximum image diameter:25 mm

Glass type: Boro silicate glass

Glass coating:dichroic

